



RESTAURANT  
HOTEL

## IL NOSTRO LAVORO

Dal 1947 il nostro lavoro è quello di produrre posate e altri articoli in acciaio per la ristorazione, usando solamente i migliori materiali e prestando la massima cura alle finiture.

Combinando l'esperienza maturata nel settore delle forniture alberghiere con il gusto per il design, rivolto alle più raffinate boutique di lista nozze e articoli per la casa, abbiamo sviluppato, accanto ai prodotti tradizionali, una serie di prodotti innovativi e di avanguardia, che seguono le nuove tendenze della moda e della ristorazione.

Il presidio diretto della produzione, nel nostro stabilimento di Lumezzane, ci consente, inoltre, di soddisfare le esigenze dei nostri clienti che richiedono particolari personalizzazioni (finiture, design, marchi)

I nostri collaboratori ed il nostro reparto ricerca e sviluppo sono a vostra disposizione per qualsiasi richiesta.



## OUR JOB

Since 1947, our mission has been to design and manufacture flatware and holloware using only the finest materials and finishing techniques. With over sixty years of professional foodservice industry experience coupled with modern utilitarian design we offer a complete range of innovative and contemporary products that are in step with the latest trends.

Our products are designed and made in Italy in our own factory. We have complete control over the design and manufacturing process and therefore can offer our customers unparalleled service and the utmost quality assurance. Furthermore, through our in-house Research and Development team we offer our customers personalized fabrication including product design, special finishing, logos, etc. to meet our customers' unique requirements. Please contact us for further details.

## NOTRE TRAVAIL

Depuis 1947 notre travail est de produire des couverts et autres articles en acier pour les restaurants, en employant seulement les meilleurs matériaux et en prêtant le plus grand soin aux finitions.

En combinant l'expérience mûrie dans le secteur des fournitures hôtelières et le goût pour le design engagé à des boutiques de liste des noces et articles pour la maison, nous avons développé auprès des produits traditionnels une série de produits innovants et d'avant-garde qui suivent les nouvelles tendances de la mode et des hôtels/restaurants.

La ligne directe de la production de notre établissement de Lumezzane, permet en outre de satisfaire les exigences de nos clients qui demandent des détails personnalisés (finitions, design, marque)

Nos collaborateurs et notre studio recherche et développement, sont à votre disposition pour toute demande.



## UNSERE BERUFUNG

Seit 1947 produzieren wir Bestecke & Servierteile, die mittels sorgfältigster Fertigungstechnik und unter Verwendung bester Materialien hergestellt werden. Durch unseren hohen Anspruch an Geschmack und Design, kombiniert mit 60-jähriger Produktionserfahrung, sind wir kompetenter Lieferant bester Design-Shops und Spezialgeschäfte rund um den Erdball. Die logische Folge unserer Philosophie und Qualifikation ist jenes umfangreiche Sortiment innovativer und zeitgenössischer Produkte, die die neusten Trends im Hotel- und Restaurantbusiness wiedergeben. Als typisches Merkmal italienischer Hersteller produzieren wir nicht nur in bestem Design und Qualität, sondern erfüllen in maximaler Flexibilität individuelle Kundenwünsche, wie z. B. individuelle Finishing, Logos und Designvarianten). Diesbezüglich kontaktieren Sie einfach unsere jeweiligen Vertriebspartner oder unsere zentrale Entwicklungsabteilung und beschreiben Ihre Vorstellungen, Wünsche und Fragen.

## NUESTRO TRABAJO

Desde el 1947 nuestro trabajo es producir cubiertos y otros artículos de acero para la restauración, empleando solamente los mejores materiales y prestando el cuidado más grande a los acabados.

Combinando la experiencia madurada en el sector de los abastecimientos hoteleros y el gusto para el design de las tiendas de lista de las bodas y los artículos para la casa, hemos desarrollado con los productos tradicionales una serie de productos innovativos y de vanguardia que siguen las nuevas tendencias de la moda y de los hoteles / restaurantes.

La línea directa de la producción de nuestro establecimiento de Lumezzane, permite satisfacer las exigencias de nuestros clientes que piden detalles personalizados (acabados, diseño, marca)

Nuestros colaboradores y nuestro estudio técnico, están a su disposición para todas las peticiones.





**MEPRÁ**  
S.p.A.

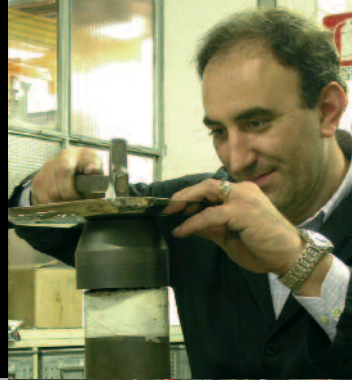

**DESIGN**



**PRODUZIONE**



**TRADIZIONE**



- 1 Tutti i materiali rispondono alla normativa riguardante il contatto con gli alimenti
- 1 Acciaio inossidabile 18/10 di altissima qualità
- 1 Policarbonato infrangibile
- 1 Polipropilene e policarbonato adatti al microonde
- 1 Tutti i prodotti sono garantiti per il lavaggio in lavastoviglie

- 1 All materials used are in accordance with laws governing food and beverages
- 1 Only the highest quality 18/10 gauge stainless steel is used
- 1 Top grade polycarbonate used for ultra clear quality and indestructible performance
- 1 Polypropylene and polycarbonate is microwave safe
- 1 All items are dishwasher safe

- 1 Tous les matériels répondent à la normative concernant le contact avec les aliments
- 1 Acier inoxydable 18/10 de haute qualité
- 1 Policarbonate incassable
- 1 Polipropilene et policarbonate aptes aux micro-ondes
- 1 Tous les produits sont garantis pour le lavage en lave-vaisselle

- 1 Alle verwendeten Materialien entsprechen den gesetzlichen Anforderungen bezüglich der Sicherheit des Kontakts mit Lebensmitteln
- 1 18/10 Chromnickelstahl höchster Qualität
- 1 Unzerbrechliches Polycarbonat
- 1 Polycarbonat und Polypropylen sind mikrowellenfest
- 1 Alle Produkte sind spülmaschinenfest

- 1 Todos los materiales responden a la normativa con respecto al contacto con los alimentos.
- 1 Acero inoxidable 18/10 de alta calidad
- 1 Policarbonato irrompible
- 1 Polipropileno y policarbonato apto para microondas
- 1 Todos los productos están garantizados para el lavado en lava-vajillas



- 1 Tutti gli articoli, incluso il vasellame, possono essere personalizzati con logo a richiesta, mediante incisione laser o punzonatura, senza quantità minima

- 1 All items can be personalized (company name, logo, etc.) using laser engraving or stamping technology. No minimum quantity is required.

- 1 Tous les articles, inclus la vaisselle, ils peuvent être personnalisés avec du logo à la demande, par gravure laser ou poinçonnage, sans quantité moindre

- 1 Alle Produkte, einschließlich die für den Hausgebrauch, können nach Wunsch mit einer Lasergravur oder anderen Beschriftung mit eigenem Logo versehen werden; eine Mindestmenge dafür ist nicht vorgeschrieben.

- 1 Todos los artículos, incluso las bandejas, pueden ser personalizadas con logo sobre demanda, mediante grabado al láser o a estampación, sin cantidad mínima.

## FINITURE - FINISHING - FINISSAGES - OBERFLACHEFINISH - FINICIONES

### ICE

I Tutti gli articoli, incluso il vasellame, possono essere prodotti anche con superficie satinata.

I All items can be manufactured with matt finish surface.

I Tous les articles, inclus la vaisselle, ils peuvent être produit avec surface satinée.

I Alle Produkte, einschließlich die für den Hausgebrauch, können nach Wunsch mit matten Finish hergestellt werden.

I Todos los artículos, incluso las bandejas, pueden ser producidos con superficie satinada.

### ORO - ORO ICE - ORO NERO - BRONZO - CHAMPAGNE - ARCOBALENO

Il rivestimento è realizzato in P.V.D. (Physical Vapor Deposition). Questa tecnologia ha origini nel campo spaziale per aumentare la resistenza dei pannelli esterni delle navicelle spaziali e nella gioielleria. Grazie alla collaborazione con primarie università italiane, siamo la prima azienda ad applicare queste finiture di diverse tonalità di colore. Le caratteristiche delle finiture sono idonee all'utilizzo nel settore alberghiero, nel campo della ristorazione.

The surface treatment is a P.V.D. process (Physical Vapour Deposition) This technology was developed for the aeronautic industry and is used to shield NASA's Space Shuttle panels against corrosion and to protect fine jewelry. In co-operation with renowned Italian Universities we were the first to apply

these treatments in order to achieve original color tonalities. The characteristics of these treatments are hard wearing and hospitality grade - ideal for distinctive hotels, restaurants and catering services.

Le revêtement est réalisé en P.V.D. (Physical Vapor Deposition). Cette technologie a origines dans le champ spatial pour augmenter la résistance des panneaux extérieurs des nacelles spatiales et dans la bijouterie. La collaboration avec universités italiennes primaires nous sommes la première usine à appliquer ces finitions de différentes tonalités de couleur.

Les caractéristiques des finitions sont aptes à la jouissance dans le secteur hôtelier, dans le camp de la restauration.



Die Oberflächenbehandlung des Bestecks ist ein P.V.D. Prozess (Physikalisches Dampf-Absetzungsverfahren).

Diese Technologie ist für die Raumfahrtindustrie entwickelt worden und wird dazu benötigt, die stark beanspruchten Flügel von Weltraumfähren widerstandsfähiger zu machen, aber auch für hochwertigen Schmuck und wertvolle Armbanduhren.

In Kooperation mit Forschungsabteilungen italienischer Hochschulen und Universitäten haben wir innovative Verfahren entwickelt, die es ermöglichen, nie dagewesene Farbtöne für Bestecke und Edelstahlaccessoires zu erreichen. Die widerstandsfähigen und hygienischen Eigenschaften bleiben.

El revestimiento esta realizado con P.V.D. (Physical Vapor Deposition) Esta tecnología original del campo espacial, se utiliza para aumentar la resistencia de los paneles exteriores de las naves espaciales y en joyería. Gracias a la colaboración de la principal universidad italiana, somos la primera empresa en aplicar esta terminación en diversas tonalidades de color. La características de estas terminaciones, son idóneas para su utilización en el sector hostelero, y de la restauración.



## SILVER-PLATED

Argentatura tramite processo galvanico con tecnologia d'avanguardia

Produzione soggetta a severi controlli qualitativi di:

quantità di argento depositato

perfetta aderenza del deposito sulla superficie

Spessore maggiorato nei punti di maggiore usura

Superiore resistenza alla graffiatura

Usare sempre prodotti specifici per la pulizia dell'argento



Silver Plating is produced by the most technologically advanced galvanic process.

The production of silver plated items is controlled with special attention to the quantity of silver and the quality of adhesion.

Thickness of silver is higher in those areas of higher wear.

Highly scratch resistant.

Silver cleaning products are recommended for maintaining the investment.

Argentage par procès galvanique avec technologie d'avant-garde

Production sujette aux contrôles qualitatifs sévères de:

quantité d'argent déposé

adhérence parfaite du dépôt sur la surface

Épaisseur augmentée dans les points de grande usure r

Résistance supérieure à la griffure

On recommande de nettoyer les objets seulement avec des produits spécifiques pour l'argent.

Die Versilberung führen wir mittels eines galvanischen Prozesses durch, der dem allerneuesten Stand der Technik entspricht.

Die Produktion versilberter Teile wird u.a. wie folgt kontrolliert:  
Genaueste Messung der Menge des verwendeten Silbers  
Ausgezeichnete Adhäsion der Versilberung auf den jeweiligen Oberflächen der Teile

Die Stärke der Silberbeschichtung wird bei den Teilen an den Stellen (z.B. Auflageflächen, Zinken) erhöht, wo die Abnutzung am größten ist.  
Höhere Widerstandsfähigkeit gegen Abnutzungsverschleiss  
Zur Reinigung empfehlen wir besonderen Silber Reinigungsmitteln zu verwenden.

Plateado con proceso galvanico y con tecnología de vanguardia  
Producción sujeta a un severo control de calidad:



Cantidad de plata depositada  
perfecta adherencia del deposito sobre la superficie  
Espesor mejorado en los puntos de mayor uso  
Superior resistencia al rallado  
Se encomienda limpiar solo con productos especificos para la plata.



# Posate



## FLATWARE COUVERTS BESTECKE CUBIERTOS

- Gamma completa per ogni modello
- Spessore elevato
- Rebbi delle forchette lavorati internamente
- Seghettatura lame passante per un taglio perfetto

- Each collection consists of an extensive range of pieces.
- Thick stainless steel.
- Fork tines are polished on all sides for a lifetime of performance.
- Knife blades have a micro-serration for an effortless cut.

- Chaque modèle est complet de toute le pièces nécessaire
- Épaisseur massifs
- Fourchons des fourchettes intérieurement travaillés
- Les couteaux possèdent la dentelure fin ouvragée pour une coupe facile

- Jedes Modell verfügt über eine komplette Bandbreite an Zusatzteilen
- Hohe Materialstärke
- Exakte, maschinell gefertigte Gabelzinken
- Genauste Ausbildung der Messerschneiden für einen perfektesten Schnitt

- Cada modelo esta completo de todo lo necesario
- Espesor macizo
- Tenedores con púas pulidas internamente.
- Cuchillos con hoja sierra; corte perfecto

**MEPRA**  
S.p.A.





Code	mm.	inch.
01	199	7 7/8
02	199	7 7/8
03	228	9
04	176	6 7/8
05	176	6 7/8
06	203	8
07	135	5 3/8
08	108	4 1/8
09	330	13
10	235	9 1/4
11	235	9 1/4
12	228	9
13	203	8
15	150	5 7/8
16	251	9 7/8
20	195	7 5/8
21	195	7 5/8
22	235	9 1/4
23	235	9 1/4
25	185	7 1/4
35	175	6 7/8
36	228	9
37	170	6 3/4
39	175	6 7/8
40	185	7 1/4
45	183	7 1/5

Coltelli disponibili anche con manico vuoto  
 Hollow handle knives available  
 Couteaux disponibles aussi avec un manche creux  
 Messer in Hohlheft-Ausführung erhältlich  
 Cuchillo disponible también en mango hueco

mm 4,0  
**ACQUA**





Code	mm.	inch.
01	201	7 7/8
02	201	7 7/8
03	227	9
04	180	7
05	180	7
06	202	8
07	139	5 1/2
08	110	4 1/3
09	295	11 2/3
10	243	9 1/2
11	243	9 1/2
15	145	5 3/4
16	243	9 1/2
20	210	8 1/4
21	192	7 1/2
22	243	9 1/2
23	243	9 1/2
35	180	7
36	227	9
37	161	6 1/3
39	180	7
40	175	6 7/8
45	203	8

Tutti i pezzi di questo modello sono realizzati in forgia  
 All pieces in this range are forged  
 Toutes les pièces de ce modèle sont forgées  
 Alle Teile dieses Modells sind geschmiedet.  
 Todas las piezas de este modelo son hechas en forgia





Code	mm.	inch.
01	208	8 1/5
02	208	8 1/5
03	235	9 1/4
04	185	7 1/4
05	185	7 1/4
06	205	8
07	140	5 1/2
08	120	4 3/4
09	275	10 7/8
10	250	9 7/8
11	250	9 7/8
15	155	6
16	260	10 1/4
20	210	8 1/4
21	185	7 1/4
22	250	9 7/8
23	250	9 7/8
25	201	7 9/8
35	185	7 1/4
36	235	9 1/4
37	183	7 3/5
39	185	7 1/4
40	180	7
45	183	7 1/4

I coltelli appoggiano sulla lama  
 Knives may be set blade-down  
 Les couteaux peuvent être posés debout sur leurs lames  
 Durch das aussergewöhnliche Design, ist es möglich, die  
 jeweiligen Messer auch hochkant, also "auf der Klinge  
 stehend", abzustellen.  
 Los cuchillos pueden apoyar sobre la hoja.

Tutti i pezzi di questo modello sono realizzati in forgia  
 All pieces in this range are forged  
 Toutes les pièces de ce modèle sont forgées  
 Alle Teile dieses Modells sind geschmiedet  
 Todas las piezas de este modelo son hechas en forgia

mm 8,0 **ARTE**





Code	mm.	inch.
01	210	8 1/4
02	208	8 1/5
03	235	9 1/4
04	190	7 1/2
05	188	7 2/5
06	212	8 1/3
07	138	5 2/5
08	109	4 1/3
09	289	11 1/3
10	240	9 1/2
11	238	9 2/5
15	157	6 1/6
16	259	10 1/3
20	223	8 3/4
21	208	8 1/5
22	240	9 1/2
23	240	9 1/2
25	208	8 1/5
36	233	9 1/6
37	178	7
39	192	7 1/2
40	170	6 2/3





Code	mm.	inch.
01	200	7 7/8
02	202	8
03	221	8 3/4
04	180	7
05	180	7
06	198	7 3/4
07	135	5 1/3
08	114	4 1/2
09	312	12 1/8
10	235	9 1/4
11	240	9 1/2
15	150	5 7/8
16	255	10
20	210	8 1/4
21	202	8
22	235	9 1/4
23	235	9 1/4
25	185	7 1/4
31	114	4 1/2
35	180	7
36	221	8 3/4
37	162	6 1/2
39	180	7
40	185	7 1/4



ICE

mm 4,0

AVANGUARDIA





Code		mm.	inch.
01		204	8
02		204	8
03		245	9 2/5
04		176	7
05		176	7
06		220	8 2/5
07		135	5 1/5
08		111	4 2/5
09		313	12 1/5
10		253	10
11		253	10
12		245	9 2/5
13		220	8 2/5
15		154	6
16		241	9 1/2
20		209	8 1/5
21		207	8 1/7
22		253	10
23		253	10
26		164	6 1/2
35		175	6 7/6
36		245	9 2/5
37		169	6 2/5
39		175	6 7/6
40		187	7 1/5
45		192	7 1/2

Coltelli disponibili anche con manico vuoto  
 Hollow handle knives available  
 Couteaux disponibles aussi avec un manche creux  
 Messer in Hohlheft-Ausführung erhältlich  
 Cuchillo disponible también en mango hueco





Code	mm.	inch.
01 	209	8 1/5
02 	209	8 1/5
03 	235	9 1/4
04 	180	7
05 	180	7
06 	204	8
07 	135	5 1/3
08 	114	4 1/2
09 	315	12 2/3
10 	250	9 7/8
11 	250	9 7/8
12 	235	9 1/4
13 	204	8
15 	155	6
16 	243	9 1/2
20 	210	8 1/4
21 	207	8 1/7
22 	250	9 7/8
23 	250	9 7/8
24 	140	5 1/2
25 	195	7 2/3
26 	155	6
35 	180	7
36 	224	8 4/5
37 	170	6 2/3
39 	180	7
40 	184	7 1/4
44 	165	6 1/2
45 	208	8 1/6

Coltelli disponibili anche con manico vuoto  
 Hollow handle knives available  
 Couteaux disponibles aussi avec un manche creux  
 Messer in Hohlheft-Ausführung erhältlich  
 Cuchillo disponible también en mango hueco

mm 3,0  
**BOHEME**





01		204	8
02		203	8
03		232	9 1/8
04		185	7 1/4
05		184	7 1/4
06		210	8 1/4
07		134	5 1/4
08		110	4 1/3
09		288	11 1/3
10		240	9 2/5
11		241	9 1/2
15		158	6 1/5
16		258	10
20		198	7 4/5
21		184	7 1/4
35		182	7 1/6
36		234	9 1/5
37		172	6 3/4



Code		mm.	inch.
01		207	8 1/8
02		207	8 1/8
03		244	9 3/5
04		179	7
05		179	7
06		219	8 3/5
07		135	5 1/3
08		114	4 1/2
09		320	12 3/5
10		250	9 5/6
11		250	9 5/6
12		244	9 3/5
13		219	8 3/5
15		157	6 1/6
16		243	9 1/2
17		242	9 1/2
18		258	10
19		250	9 5/6
20		212	8 1/3
21		206	8 1/3
22		250	9 5/6
23		250	9 5/6
35		180	7
36		225	8 5/6
37		174	6 7/6
39		179	7
40		188	7 2/5

Coltelli disponibili anche con manico vuoto  
 Hollow handle knives available  
 Couteaux disponibles aussi avec un manche creux  
 Messer in Hohlheft-Ausführung erhältlich  
 Cuchillo disponible también en mango hueco

mm 3,0  
**CELLINI**





Code	mm.	inch.
01	206	8 1/8
02	206	8 1/8
03	240	9 2/5
04	178	7
05	178	7
06	214	8 2/5
07	133	5 1/4
08	113	4 2/5
09	315	12 2/5
10	245	9 2/5
11	245	9 2/5
12	240	9 2/5
13	214	8 2/5
15	155	6
16	241	9 1/2
20	210	8 1/4
21	206	8 1/8
22	240	9 2/5
23	244	9 3/5
25	208	8 1/6
26	156	6 1/7
35	178	7
36	240	8 1/8
37	169	6 2/5
39	178	7
40	183	7 1/5
44	165	6 1/2
45	177	7



PELTRO

Coltelli disponibili anche con manico vuoto  
 Hollow handle knives available  
 Couteaux disponibles aussi avec un manche creux  
 Messer in Hohlheft-Ausführung erhältlich  
 Cuchillo disponible también en mango hueco





Code	mm.	inch.
01	200	7 7/8
02	200	7 7/8
03	225	8 7/8
04	175	6 8/9
05	180	7
06	200	7 7/8
07	135	5 1/3
08	110	4 1/3
09	298	11 3/4
10	235	9 1/4
11	245	9 2/3
15	150	6
16	252	10
20	185	7 1/4
21	185	7 1/4
22	235	9 1/4
23	235	9 1/4
25	185	7 1/4
35	180	7
36	225	8 5/8
37	193	7 3/5
39	178	7
40	180	7
45	189	7 2/5

- ICE
- ORO ICE
- ORO NERO
- BRONZO
- CHAMPAGNE
- ARCOBALENO

mm 4,0  
**DUE**





Code		mm.	inch.
01		205	8
02		206	8 1/8
03		235	9 1/4
04		175	6 8/9
05		175	6 8/9
06		202	8
07		134	5 1/4
08		111	4 1/3
09		302	11 8/9
10		231	9
11		233	9 1/6
15		157	6 1/6
16		241	9 1/2
20		184	7 1/4
21		175	6 8/9
22		231	9
23		231	9
36		235	9 1/4
37		175	6 8/9
39		175	6 8/9
40		173	6 4/5





Code		mm.	inch.
01		203	8
02		200	7 7/8
03		220	8 2/3
04		178	7
05		185	7 1/4
06		195	7 2/3
07		135	5 1/3
08		113	4 2/5
09		310	12 1/5
10		245	9 2/3
11		241	9 1/2
15		150	5 8/9
16		255	10
20		197	7 3/4
21		185	7 1/3
22		245	9 2/3
23		245	9 2/3
25		201	8
35		178	7
36		220	8 2/3
37		195	7 2/3
39		178	7
40		180	7

mm 4,0

ENERGIA





Code		mm.	inch.
01		209	8 1/5
02		209	8 1/5
03		240	9 1/2
04		180	7
05		180	7
06		214	8 2/5
07		136	5 1/3
08		114	4 1/2
09		315	12 2/5
10		250	9 7/8
11		250	9 7/8
12		240	9 1/2
13		214	8 2/5
15		155	6
16		243	9 1/2
20		210	8 1/4
21		207	8 1/7
22		250	9 7/8
23		250	9 7/8
35		190	7 1/2
36		227	9
37		172	6 3/4
39		180	7
40		184	7 1/4
44		165	6 1/2
45		208	8 1/6



Coltelli disponibili anche con manico vuoto  
 Hollow handle knives available  
 Couteaux disponibles aussi avec un manche creux  
 Messer in Hohlheft-Ausführung erhältlich  
 Cuchillo disponible también en mango hueco





Code		mm.	inch.
01		205	8
02		200	7 7/8
12		215	8 2/5
04		193	7 3/5
05		178	7
13		192	7 1/2
07		138	5 2/5
09		293	11 1/2
10		249	9 4/5
11		249	9 4/5
15		172	6 3/4
16		252	10
20		211	8 1/5
21		204	8
40		201	7 8/5

Coltelli disponibili anche con manico pieno.  
 Solid handle knives available.  
 Couteaux disponibles aussi avec un manche plein.  
 Auch Monoblock- Messer erhältlich.  
 Cuchillo disponible también en mango lleno.



Angelo Mangiarotti

Tutti i pezzi di questo modello sono realizzati con manico vuoto.  
 All the pieces in this range are realized with hollow handle.  
 Toutes les pièces de ce modèle sont réalisées avec les manches vides.  
 Alle Teile dieses Modells sind in Hohlheft-Ausführung verarbeitet.  
 Todas las piezas de este modelo son hechas a mango hueco.

mm 3,0

**ERGONOMICA**





Code	mm.	inch.
01	210	8 1/4
02	210	8 1/4
03	234	9 1/5
04	190	7 1/2
05	187	7 1/3
06	208	8 1/5
07	142	5 3/5
08	120	4 3/4
09	300	11 4/5
10	255	10
11	250	9 5/6
15	160	6 1/3
16	280	11
20	212	8 1/3
21	186	7 1/3
22	255	10
23	255	10
25	195	7 2/3
35	188	7 2/5
36	234	9 1/5
37	198	7 4/5
39	190	7 1/2
40	191	7 1/2
45	193	7 3/5

I coltelli appoggiano sulla lama  
 Knives may be set blade-down  
 Les couteaux peuvent être posés debout sur leurs lames  
 Durch das aussergewöhnliche Design, ist es möglich, die  
 jeweiligen Messer auch hochkant, also "auf der Klinge  
 stehend", abzustellen.  
 Los cuchillos pueden apoyar sobre la hoja.

Tutti i pezzi di questo modello sono realizzati in forgia  
 All pieces in this range are forged  
 Toutes les pièces de ce modèle sont forgées  
 Alle Teile dieses Modells sind geschmiedet  
 Todas las piezas de este modelo son hechas en forgia





Code		mm.	inch.
01		214	8 2/5
02		214	8 2/5
03		247	9 3/4
04		189	7 2/5
05		189	7 2/5
06		218	8 3/5
07		144	5 2/3
08		116	4 1/2
09		300	11 4/5
10		256	10
11		256	10
15		156	6 1/7
16		274	10 3/4
20		212	8 1/3
21		189	7 2/5
22		256	10
23		256	10
36		247	9 3/4
37		218	8 3/5
44		165	6 1/2



ICE

ADV  
Astier de Villatte

mm 3,0

GINEVRA





Code		mm.	inch.
01		195	7 2/5
02		195	7 2/5
03		218	8 3/5
04		173	6 4/5
05		173	6 4/5
06		195	7 2/5
07		130	5 1/5
08		112	4 2/5
09		299	11 3/4
10		234	9 1/5
11		234	9 1/5
15		154	6
16		251	9 9/5
20		197	7 3/4
21		195	7 2/5
22		234	9 1/5
23		234	9 1/5
35		175	6 4/5
36		218	8 3/5
37		153	6
39		173	6 4/5
40		184	7 1/4





Code		mm.	inch.
01		202	8
02		202	8
03		231	9
04		176	6 8/9
05		176	6 8/9
06		204	8
07		138	5 2/5
08		106	4 1/6
09		330	13
10		235	9 1/4
11		235	9 1/4
15		150	5 8/9
16		251	9 8/9
20		202	8
21		202	8
22		235	9 1/4
23		235	9 1/4
25		185	7 1/4
36		210	8 1/4
37		185	7 1/4
39		182	7 1/6
40		185	7 1/4

mm 4,0  
**IMMAGINA**













Code	mm.	inch.
01	203	8
02	203	8
03	210	8 1/4
04	177	7
05	177	7
06	190	7 1/2
07	133	5 1/4
08	113	4 2/5
09	308	12 1/8
10	237	9 1/3
11	237	9 1/3
15	157	6 1/6
16	248	9 3/4
18	241	9 1/2
20	203	8
21	203	8
22	237	9 1/3
23	237	9 1/3
24	134	5 1/4
35	177	7
37	177	7
39	177	7
40	187	7 1/3
45	177	7



ICE



Code		mm.	inch.
01		207	8 1/8
02		201	7 7/8
03		219	8 3/5
04		178	7
07		134	5 1/4
08		120	4 3/4
15		135	5 1/3
21		210	8 1/4

Arch. Katja Bremkamp

The asymmetrical and rather unfamiliar shape of this cutlery range was influenced by the way we handle certain situations relating to the table routine. I was looking at the movements of the hands when dishing food out of bowls, when serving onto a plate and how this movement alters when food is conveyed into the mouth. Each piece reflects these movements individually, referring to their purposes and their "actions", as some pieces are more asymmetrical than others. The overall asymmetrical shape of this range therefore supports the comfortable handling of cutlery and also acts as guide to the person who is using it.

La forma asimmetrica e non convenzionale di questo modello è stata influenzata dall'osservazione dei comportamenti e delle routine legate al consumo del cibo a tavola. Ho guardato i movimenti delle mani durante la disposizione del cibo sul piatto, la raccolta del boccone e l'accompagnamento alla bocca. Ogni pezzo riflette individualmente questi movimenti, riferendosi al loro scopo e alle loro azioni; questo spiega il motivo per cui alcuni pezzi sono più asimmetrici di altri. Oltretutto, l'asimmetria di questa linea avvantaggia la maneggevolezza della posata in modo da guidare la persona che la usa.



ICE

mm 3,0

KATJA





Code	mm.	inch.
01	208	8 1/5
02	208	8 1/5
03	235	9 1/4
04	180	7
05	180	7
06	210	8 1/4
07	133	5 1/4
08	115	4 1/2
09	315	12 2/5
10	248	9 3/4
11	245	9 2/5
12	235	9 1/4
13	210	8 1/4
15	156	6 1/7
16	242	9 1/2
18	250	9 5/6
19	250	9 5/6
20	210	8 1/4
21	210	8 1/4
22	248	9 3/4
23	248	9 3/4
24	134	5 1/4
25	205	8
26	156	6 1/7
35	180	7
36	235	9 1/4
37	170	6 2/5
39	180	7
40	185	7 1/4
44	175	6 8/9
45	180	7

Coltelli disponibili anche con manico vuoto  
 Hollow handle knives available  
 Couteaux disponibles aussi avec un manche creux  
 Messer in Hohlheft-Ausführung erhältlich  
 Cuchillo disponible también en mango hueco





Code		mm.	inch.
01		205	8
02		205	8
03		233	9 1/6
04		179	7
05		179	7
06		200	7 7/8
07		135	5 1/3
08		113	4 2/5
09		316	12 2/5
10		239	9 2/5
11		245	9 2/3
15		160	6 1/3
16		244	9 3/5
20		205	8
21		208	8 1/5
22		239	9 2/5
23		239	9 2/5
25		201	8
26		158	6 1/5
35		155	6 1/8
36		233	9 1/6
37		163	6 2/5
39		179	7
40		182	7 1/6
45		179	7



ICE

Maurizio Duranti

mm 3,5

# LEVANTINA





Code	mm.	inch.
01	200	7 7/8
02	203	8
03	235	9 1/4
04	178	7
05	180	7
06	205	8
07	135	5 1/3
08	115	4 1/2
09	305	12
10	245	9 2/3
11	245	9 2/3
15	150	6
16	246	9 2/3
20	200	7 7/8
21	187	7 1/3
22	245	9 2/3
23	245	9 2/3
25	185	7 1/3
35	178	7
36	235	9 1/4
37	178	7
39	178	7
40	190	7 1/2

- ICE
- ORO ICE
- ORO NERO
- BRONZO
- CHAMPAGNE
- ARCOBALENO



Coltelli disponibili anche con manico vuoto  
 Hollow handle knives available  
 Couteaux disponibles aussi avec un manche creux  
 Messer in Hohlheft-Ausführung erhältlich  
 Cuchillo disponible también en mango hueco

Code	mm.	inch.
01	208	8 1/5
02	208	8 1/5
03	224	8 4/5
04	183	7 1/5
05	183	7 1/5
06	195	7 2/5
07	135	5 1/5
08	115	4 1/2
09	293	11 1/2
10	265	10 2/5
11	265	10 2/5
12	224	8 4/5
13	195	7 2/5
15	152	6
16	257	10 1/5
20	223	8 3/4
21	209	8 1/5
22	265	10 2/5
23	265	10 2/5
25	201	8
26	152	6
35	183	7 1/5
36	224	8 4/5
37	171	6 3/4
39	183	7 1/5
40	180	7



ICE

**Diciottesimo  
 Premio Compasso d'Oro  
 ADI**

Mediterranea  
 Posate  
**Maurizio Duranti**  
 Designer  
**Mepra spa**  
 Produttore

Selezione d'onore  
 Compasso d'Oro  
 ADI 1998

Maurizio Duranti





01		209	8 1/5
02		209	8 1/5
03		235	9 1/4
04		180	7
05		180	7
06		204	8
07		136	5 1/3
08		114	4 1/2
09		315	12 2/3
10		250	9 5/6
11		250	9 5/6
12		235	9 1/4
13		204	8
15		155	6 1/3
16		243	9 1/2
17		236	9 1/3
18		253	10
19		251	9 5/6
20		210	8 1/4
21		207	8 1/7
22		250	9 5/6
23		250	9 5/6
24		140	5 1/2
25		195	7 2/3
26		155	6 1/3
35		190	7 1/2
36		224	8 4/5
37		170	6 2/3
39		180	7
40		184	7 1/4
44		165	6 1/2
45		208	8 1/5

Coltelli disponibili anche con manico vuoto  
 Hollow handle knives available  
 Couteaux disponibles aussi avec un manche creux  
 Messer in Hohlheft-Ausführung erhältlich  
 Cuchillo disponible también en mango hueco





Giulio Iacchetti

Code		mm.	inch.
01		201	8
02		201	8
03		219	8 2/5
04		180	7
05		180	7
06		195	7 2/5
07		140	5 1/2
08		113	4 2/5
09		320	12 3/5
10		245	9 2/5
11		245	9 2/5
15		153	6
16		256	10
20		213	8 2/5
21		206	8 1/5
22		245	9 2/5
23		245	9 2/5
25		201	8
35		180	7
36		219	8 2/5
37		195	7 2/5
39		180	7
40		190	7 1/2

mm 3,0  
**MORGANA**





Code	mm.	inch.
01	200	7 7/8
02	204	8
03	230	9
04	180	7
05	180	7
06	204	8
07	135	5 1/5
08	113	4 2/5
09	310	12 1/5
10	240	9 1/2
11	245	9 2/3
15	150	5 8/9
16	252	10
20	222	8 3/4
21	203	8
22	240	9 1/2
23	240	9 1/2
25	201	8
35	180	7
36	230	9
37	204	8
39	180	7
40	180	7

I coltelli appoggiano sulla lama  
 Knives may be set blade-down  
 Les couteaux peuvent être posés debout sur  
 leurs lames  
 Durch das aussergewöhnliche Design, ist es  
 möglich, die jeweiligen Messer auch hochkant,  
 also "auf der Klinge stehend", abzustellen.  
 Los cuchillos pueden apoyar sobre la hoja





Code		mm.	inch.
01		201	7 8/9
02		201	7 8/9
03		232	9 1/8
04		170	6 2/3
05		175	6 8/9
06		199	7 4/5
07		133	5 1/4
08		110	4 1/3
09		314	12 1/3
10		250	9 5/6
11		255	10
12		232	9 1/8
13		199	7 4/5
15		152	6
16		245	9 2/3
20		170	6 2/3
21		173	6 4/5
22		250	9 5/6
23		250	9 5/6
25		195	7 2/3
26		155	6 1/5
35		175	6 8/9
36		224	8 4/5
37		171	6 3/4
39		170	6 2/3
40		190	7 1/2
45		182	7 1/6

ICE

Coltelli disponibili anche con manico vuoto  
 Hollow handle knives available  
 Couteaux disponibles aussi avec un manche creux  
 Messer in Hohlheft-Ausführung erhältlich  
 Cuchillo disponible también en mango hueco

mm 4,0  
**NATURA**





Coltelli disponibili anche con manico vuoto  
 Hollow handle knives available  
 Couteaux disponibles aussi avec un manche creux  
 Messer in Hohlheft-Ausführung erhältlich  
 Cuchillo disponible también en mango hueco

Code	mm.	inch.
01	205	8
02	205	8
03	230	9
04	175	6 7/8
05	175	6 7/8
06	203	8
07	133	5 1/4
08	112	4 1/2
09	310	12 1/2
10	254	10
11	255	10
12	230	9
13	203	8
15	152	6
16	243	9 3/5
17	239	9 3/5
18	254	10
19	252	10
20	206	8 1/5
21	206	8 1/5
22	254	10
23	254	10
24	135	5 1/3
25	195	7 3/5
26	160	6 1/3
27	160	6 1/3
28	180	7
35	175	6 7/8
36	233	9 1/6
37	171	6 3/4
39	175	6 7/8
40	188	7 3/5
44	165	6 1/2
45	175	6 7/8

mm 2,5  
**NORMA**





Code	mm.	inch.
01	209	8 1/5
02	209	8 1/5
03	235	9 1/4
04	180	7
05	180	7
06	204	8
07	136	5 1/5
08	114	4 1/2
09	315	12 2/5
10	250	9 7/8
11	250	9 7/8
12	235	9 1/4
13	204	8
15	155	6
16	243	9 1/2
20	210	8 1/4
21	207	8 1/4
22	250	9 7/8
23	250	9 7/8
25	195	7 2/5
26	155	6 1/5
35	190	7 1/2
36	235	9 1/4
37	170	6 2/5
39	180	7
40	184	7 1/4
44	165	6 1/2
45	180	7

Coltelli disponibili anche con manico vuoto  
 Hollow handle knives available  
 Couteaux disponibles aussi avec un manche creux  
 Messer in Hohlheft-Ausführung erhältlich  
 Cuchillo disponible también en mango hueco





Code		mm.	inch.
01		205	8
02		205	8
03		236	9 1/2
04		180	7
05		180	7
06		200	7 7/8
07		135	5 1/2
08		115	4 1/2
09		320	12 3/4
10		250	9 7/8
11		250	9 7/8
12		236	9 1/2
13		200	7 7/8
15		155	6 1/2
16		242	9 1/2
17		236	9 1/2
20		180	7
21		180	7
22		250	9 7/8
23		250	9 7/8
25		195	7 2/3
26		155	6 1/2
35		180	7
36		224	8 4/5
37		170	6 2/3
39		180	7
40		185	7 1/4
44		165	6 1/2
45		208	8 1/5

Coltelli disponibili anche con manico vuoto  
 Hollow handle knives available  
 Couteaux disponibles aussi avec un manche creux  
 Messer in Hohlheft-Ausführung erhältlich  
 Cuchillo disponible también en mango hueco





Code	mm.	inch.
01	204	8
02	204	8
03	239	9 2/5
04	175	6 8/9
05	175	6 8/9
06	203	8
07	133	5 1/4
08	109	4 1/3
09	313	12 1/3
10	232	9 1/8
11	232	9 1/8
12	239	9 2/5
13	203	8
15	156	6 1/5
16	244	9 3/5
17	241	9 1/2
18	242	9 1/2
19	240	9 2/5
20	206	8 1/5
21	203	8
22	232	9 1/8
23	232	9 1/8
24	134	5 1/4
26	159	6 1/4
35	190	7 1/2
36	239	9 2/5
37	180	7
39	175	6 8/9
40	188	7 2/5
45	208	8 1/5

Coltelli disponibili anche con manico vuoto  
 Hollow handle knives available  
 Couteaux disponibles aussi avec un manche creux  
 Messer in Hohlheft-Ausführung erhältlich  
 Cuchillo disponible también en mango hueco

mm 3,0  
**SOLE**





Code	mm.	inch.
01	208	8 1/5
02	208	8 1/5
03	234	9 1/5
04	185	7 1/4
05	183	7 1/5
06	208	8 1/5
07	138	5 2/5
08	109	4 1/3
09	317	12 1/2
10	240	9 1/2
11	245	9 2/3
15	157	6 1/5
16	240	9 1/2
20	182	7 1/6
21	175	6 8/9
22	240	9 1/2
23	240	9 1/2
40	175	6 8/9





Code	mm.	inch.
01	204	8
02	201	7 7/8
03	231	9
04	184	7 1/4
05	182	7 1/6
06	209	8 1/5
07	135	5 1/3
08	110	4 1/3
09	280	11
10	231	9
11	234	9 1/5
15	153	6
16	260	10 1/4
20	197	7 3/4
21	201	7 8/9
35	178	7
36	230	9
37	172	6 3/4

mm 3,0

# STOCCOLMA

























Giulio Iacchetti

Code	mm.	inch.
01	200	7 7/8
02	200	7 7/8
03	211	8 1/3
04	177	7
05	177	7
06	189	7 2/5
07	135	5 1/3
08	112	4 2/5
09	295	11 3/5
10	240	9 1/2
11	240	9 1/2
13	189	7 2/5
15	150	5 8/9
16	256	10
20	215	8 2/5
21	199	7 4/5
22	240	9 1/2
23	240	9 1/2
25	201	8
37	189	7 2/5
39	177	7
40	183	7 1/5



Coltelli disponibili anche con manico vuoto  
Hollow handle knives available  
Couteaux disponibles aussi avec un manche creux  
Messer in Hohlheft-Ausführung erhältlich  
Cuchillo disponible también en mango hueco



Code		mm.	inch.
01		206	8 1/8
02		206	8 1/8
12		238	9 2/5
04		179	7
05		179	7
13		212	8 1/3
07		132	5 1/5
08		110	4 1/3
09		306	12
10		250	9 5/6
11		250	9 5/6
15		155	6 1/5
16		240	9 2/5
20		212	8 1/3
21		207	8 1/7
22		250	9 5/6
23		250	9 5/6
35		180	7
36		236	9 1/3
37		190	7 1/2
39		179	7
40		185	7 1/4



Coltelli disponibili solo con manico vuoto  
 Hollow handle knives only  
 Couteaux disponibles seulement avec un manche creux  
 Messer ausschliesslich in Hohlheft-Ausführung erhältlich  
 Cuchillos disponibles solo con mango hueco

mm 3,5  
**VITTORIA**





Maurizio Duranti

Questo modello e quello delle due pagine seguenti, sono disponibili nella versione ICE, ovvero con superficie satinata.

This model and that of the two following pages, are available in ICE version, that means with brushed finish surface.

Ce modèle et celui des deux pages après, sont disponibles dans la version ICE, qui signifie avec la surface de fin brossée.

Dieses Modell und die der folgenden zwei Seiten sind Ausführungen in der ICE Version. Sie verfügen über eine matte, gebürstete Oberfläche.

Este modelo y el de los dos páginas después, están disponibles en la versión ICE, que quiere decir con la superficie satinada





45 DUE ICE



41 ITALIA ICE



39 LEVANTINA ICE



47 LINEA ICE





57 GINEVRA ICE



42 NATURA ICE



40 MEDITERRANEA ICE



53 AVANGUARDIA ICE





Tutti i modelli delle pagine precedenti in versione acciaio inossidabile 18/10 lucido ed Ice, così come i modelli delle pagine seguenti in versione Titanio, sono completi di tutto ciò che serve in un ambiente a 5 stelle.

All of the flatware lines shown in the preceding pages in polished and brushed 18/10 gauge stainless steel, as well as those shown in the following pages in Titanium finishes, carry an extensive range of pieces, making them perfect for use in a 5-star setting.

Tous les modèles de la page précédente son dans la version acier inoxydable brillant et ICE, come les modèles des pages suivantes en Titane. Les series son complètes de toute l'ambiance d'un 5 étoiles.

Alle Besteckmodelle der vorhergehenden Seiten in poliertem und mattierte 18/10 Edelstahl verfügen, ebenso wie alle Modelle der nachfolgenden Seiten, die eine titanisierte Oberfläche aufweisen, über eine grosse Bandbreite von Einzel- bzw. Spezialteilen, ideal für die Verwendung in einem 5-Sterne Ambiente.

Todos los modelos de las paginas anteriores en versión acero inoxidable 18/10, así como los modelos de las paginas siguientes en versión Titanio, tienen la gama completa de todo necesario en un ambiente de 5 estrellas.





DESIGNPREIS  
2009

## NOMINEE

La speciale finitura non è ottenuta con metodi tradizionali come verniciatura o bagno galvanico, ma con un processo di impiantazione molecolare a base di titanio, frutto della ricerca aerospaziale.

Il prodotto è garantito per il lavaggio in lavastoviglie, non si macchia, non si ossida e resiste alla corrosione.

Unlike products that are coated or made with a galvanic process, our's is obtained using a titanium based molecular embedding process originally developed through aerospace research.

The product is dishwasher-safe, will not stain or oxidize and is highly resistant to corrosion.

Le produit n'est pas enduit ou fait avec un processus galvanique, Il est obtenu avec un processus à base de titane de d'implantation Moléculaire qui est le résultat de la recherche aérospatiale.

Le produit passe au lave-vaisselle, ne rouille pas ou ne s'oxyde pas et ne marque pas.

Die hier und vorher abgebildeten Bestecke, die mit einer Oberfläche aus Titan versehen sind, haben exakt die Farbe von Gold (ORO ICE), tiefem Schwarz (ORO NERO) und Bronze (BRONZO), was der Gestaltung von Tischen und Wohnräumen völlig neue Akzente verleiht. Das angewendete Veredelungsverfahren (P.V.D.) kommt aus der Raumfahrttechnik und war bisher bei der Gestaltung von Tabletop-Artikeln noch nie nicht angewendet worden bzw. völlig unbekannt.

Diese Produkte haben Dank des Titans eine 4 mal so harte Oberfläche wie Edelstahl, sehen nicht nur schön aus, sondern sind absolut robust und für den täglichen Gebrauch bestens geeignet.

Anfang des Jahres 2008 bekamen die Besteckmodell den begehrten Designpreis "Design Plus 2008" verliehen

El acabado especial no se obtiene de métodos tradicionales como barnizados o baño galvánico, se obtiene mediante un proceso de implantación molecular a base de titanio, fruto de la búsqueda aeroespacial.

El producto esta garantizado para el lavado en lava-vajillas, no se mancha, no se oxida y es resistente a la corrosión.

pag. 230

pag. 230



88 DUE ORO



89 LINEA ORO









92 DUE CHAMPAGNE



86 DUE ORO NERO



93 LINEA CHAMPAGNE



87 LINEA ORO NERO







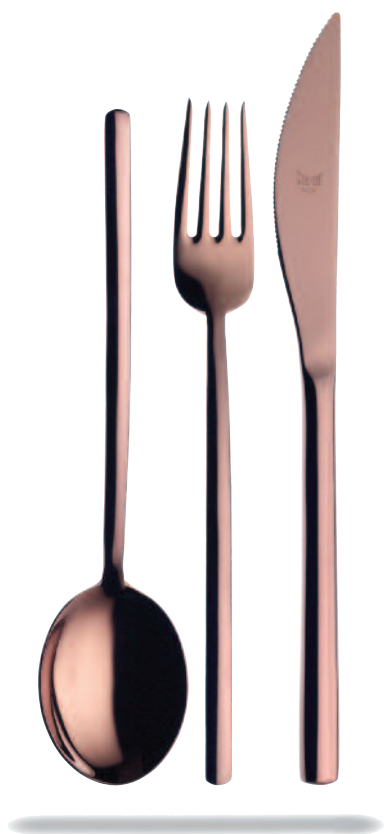

90 DUE BRONZO



80 DUE ICE ORO



91 LINEA BRONZO



81 LINEA ICE ORO









94 DUE ARCOBALENO



99 LINEA ARCOBALENO









01

Cucchiaino Tavola  
Table spoon  
Cuillère table  
Tafellöffel  
Cuchara de mesa

Cucchiaino per minestre e primi piatti  
Spoon for soups and first courses

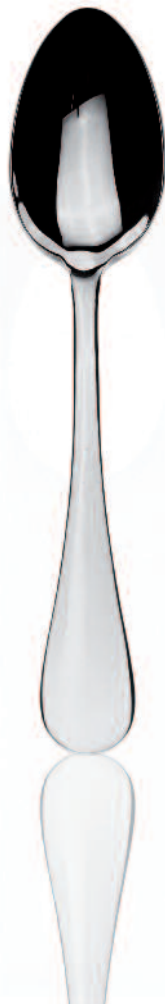

04

Cucchiaino Frutta  
Dessert spoon  
Cuillère à dessert  
Dessertlöffel  
Cuchara postre

Cucchiaino per dessert a base di crema e salse. Molto utile anche per la prima colazione  
Spoon for cream or sweet sauce desserts, very helpful for breakfast to.



07

Cucchiaino Caffè  
Tea spoon  
Cuillère à café  
Kaffeelöffel  
Cuchara café

In realtà è un cucchiaino per tè e tisane, utilizzato anche per le zuccheriere e le formaggere. Dato i molteplici utilizzi, è sempre meglio possederne una mezza dozzina in più rispetto al resto della pezzeria. This is just a tea or herbal tea spoon, but is also used with sugar bowls and cheese basins. For this reason, it is better to have half of a dozen more than the rest of the cutlery.



08

Cucchiaino Moka  
Coffee spoon  
Cuillère à moka  
Mokkalöffel  
Cucharita moka

Cucchiaino per caffè  
This is a coffee spoon

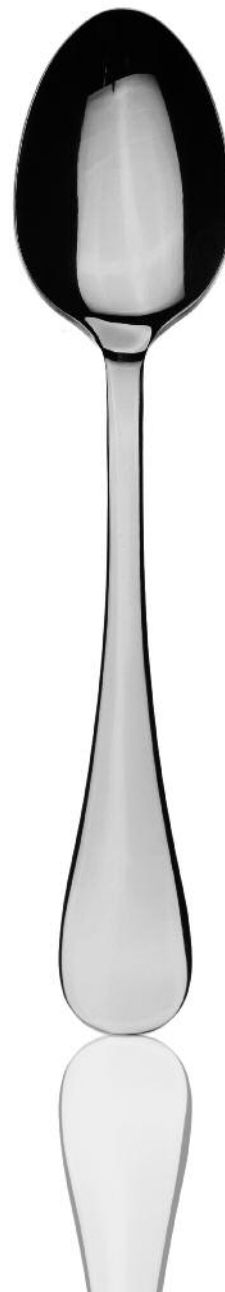

10

Cucchiaino a servire  
Cooking spoon  
Cuillère à légumes/ à ragùt  
Gemüselöffel  
Cuchara legumbres

Si usa per servire sia primi piatti sia piatti principali. Buona regola possederne in quantità doppia rispetto al forchettone  
It's used to serve first and main courses. It is better to have this cover twice than the cooking fork.



22

Cucchiaino Insalata  
Salad serving spoon  
Cuillère à salade servir  
Salatvorlegelöffel  
Cuchara servir ensalada

Si usa per mescolare e servire insalate, ma non solo: ottimo per servire antipasti a base di verdure e pesce. It is used to mix and serve salads, but is also very good to serve fish and vegetable hors-d'oeuvres.





23

Forchetta Insalata  
Salad serving fork  
Fourchette à salade servir  
Salatvorlegegabel  
Tenedor servir ensalada

Forchetta insalata  
Si usa in coppia con  
il cucchiaino insalata  
Salad serving fork  
It is used with the  
salad spoon for serving.

25

Cucchiaino Bibita  
Ice tea spoon  
Cuillère à soda  
Limonadenöffel  
Cucharita refresco

Cucchiaino per  
cocktail e gelati  
con creme in  
coppe profonde  
Spoon used for  
cocktails and  
ice-creams served  
in deep drinking-  
glasses.

44

Cucchiaino Cappuccino  
Cappuccino spoon  
Cuillère à cappuccino  
Cappuccinolöffel  
Cucharita cappuccino

Cucchiaino per  
cocktail e gelati  
con creme in  
coppe profonde  
Spoon used for  
cocktails and ice-  
creams served in  
deep drinking-  
glasses.

39

Cucchiaino Gourmet  
Gourmet spoon  
Cuillère à dégustation  
Kostprobelöffel  
Cuchara degustación

Cucchiaino per dolci  
e pesce con salse.  
La parte schiacciata  
della tazza, consente  
sia di tagliare la  
pietanza, che di  
raccolgerne il sugo.  
It's the spoon used  
for cakes and fish  
with sauce. The  
crushed part of the  
cup, allows both  
to cut the course  
and to collect the  
juice.

45

Cucchiaino Degustazione  
French sauce spoon  
Cuillère à sauce individuelle  
Gourmetlöffel  
Cuchara salsa gourmet

Paletta per pesce  
con salse, adatta a  
tagliare il pezzo ed  
a raccoglierne la  
salsa.  
Scoop for fish with  
sauces, used to  
cut the piece and  
to reap the sauce.

35

Cucchiaino Zuppa  
Soup spoon  
Cuillère à soupe  
Tassenlöffel rund  
Cuchara para sopa

Cucchiaino per  
consommé, tipica  
forma di cucchiaino  
per minestre in  
brodo della tradizione  
inglese.  
It's the consommé  
spoon used for the  
traditionals English  
soups.

26

Cucchiaino americano  
American coffee spoon  
Cuillère pour enfant  
Kinderlöffel  
Cucharita bebé

Cucchiaino per il  
caffè americano. il  
cappuccino, la  
prima colazione,  
oppure per dessert  
a base di creme e  
salse.  
Spoon used for  
american coffee,  
cappuccino, breakfast  
or for dessert with  
cream and sauces.





02

Forchetta Tavola  
Table fork  
Fourchette table  
Tafelgabel  
Tenedor de mesa

Forchetta per primi piatti e piatto principale. Dato che è il pezzo in assoluto più utile ed usato, è sempre meglio possederne in doppia quantità rispetto agli altri pezzi.  
Fork for first and main courses. It's better to have this cover twice, because it is the most useful one.



05

Forchetta Frutta  
Dessert fork  
Fourchette à dessert  
Dessertgabel  
Tenedor postre

Forchetta per antipasto e per dessert a base di frutta. Utilizzata per sbaglio spesso anche per i dessert a base dolce.  
Hors d'oeuvre fork used for fruit desserts, it is wrongly used for sweet desserts.



15

Forchettina Dolce  
Cake fork  
Fourchette à gateaux  
Kuchengabel  
Tenedor pastel

Forchetta per tutti i dolci e dessert, tranne quelli a base di frutta  
Fork used only for cakes and sweet desserts, but not for fruit.



27

Forchettina Bebè  
Baby fork  
Fourchette pour enfant  
Kindergabel  
Tenedor bebè

Forchetta per bambini.  
Fork for babies courses.



21

Forchetta Pesce da tavola  
Table fish fork  
Fourchette poisson table  
Fischgabel  
Tenedor pescado

Forchetta per pesce e molluschi  
Fork for fishes and Mollusca



11

Forchettone a servire  
Serving fork  
Fourchette à légumes/ à servir  
Fleischgabel  
Tenedor legumbres

Si usa per servire sia primi piatti sia piatti principali.  
It's used to serve first and main courses





03

Coltello Tavola  
Table knife  
Couteau table  
Tafelmesser  
Cuchillo de mesa

Coltello per piatto principale. Può essere in manico cavo, come le vecchie consigli in tavola in argento, leggero ed esclusivo; oppure in manico pieno prodotto con la tecnologia della forgiatura.

Table knife: Knife for main dishes with hollow handle, light and exclusive like the old fashioned silver covers or onepiece handle, made by the forging technology.



06

Coltello Frutta  
Dessert knife  
Couteau à dessert  
Dessertmesser  
Cuchillo postre

Coltello per antipasto e per dessert in combinazione con la forchetta frutta. Per qualità vale lo stesso discorso del coltello tavola

Used with the fruit fork in the hors-d'oeuvre and the fruit desserts. It's quality is the same of the table knife.



20

Paletta Pesce da tavola  
Table fish knife  
Couteau poisson table  
Fischmesser  
Cuchillo pescado

Coltello per tagliare pesce e molluschi  
Knife used to slice fishes and Mollusca



28

Coltellino Bebè  
Baby knife  
Couteau pour enfant  
Kindermesser  
Cuchillo bebè

Coltellino per bambini.  
Knife for babies courses.



36

Coltello Bistecca  
Steak knife  
Couteau à viande  
Steakmesser  
Cuchillo bistek

Coltello con lama profonda per bistecche di spessore.  
Sharpedged blade knife helpful to cut substantial steaks



37

Coltello per burro  
Butter knife  
Couteau à beurre  
Buttermesser  
Cuchillo para mantequilla

Coltello per burro utilizzato per la prima colazione. Nella tradizione nordica ed inglese utilizzato sulla tavola accanto al posto tavola, per spalmare il burro sul pane in occasione di lunch e dinner.

Butter cover used during breakfast. In England and in the North European countries during lunch or dinner it is put in a dish near the table set to spread butter on the bread.



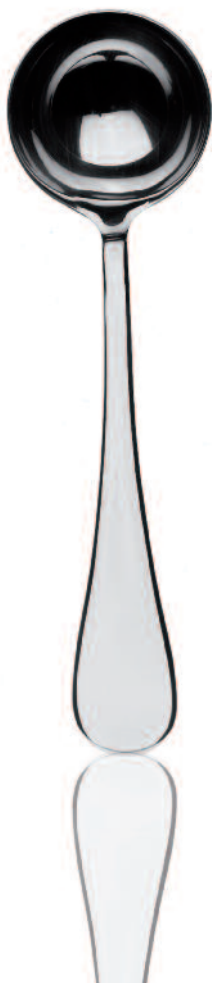

40

Mestolino per Salsa  
Gravy ladle  
Cuillère à sauce  
Saucenöffel  
Cacillo para salsaera

Si usa per servire  
salse e condimenti  
dalla salsiera  
It is used to take sau-  
ces and aromatic con-  
diments from the  
gravy boat.



16

Pala per Torta  
Cake trowel  
Pelle à tarte  
Tortenheber  
Pala tarta

Si usa per tagliare e  
servire torte e semi-  
freddi  
It is used to portion  
and serve cakes or  
"semifreddi" (some  
kinds of Italian icecre-  
am).

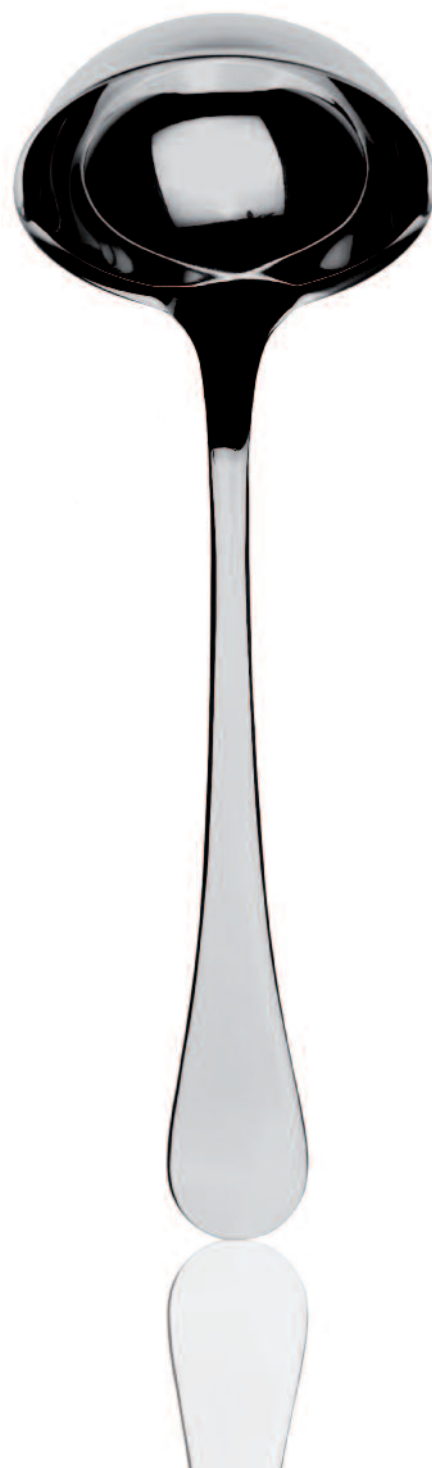

09

Mestolo a servire  
Ladle  
Louche  
Suppenshöpfer  
Cazo Sopa

Si usa per servire mine-  
stre dalla zuppiera al piat-  
to fondo  
It's used to serve soups  
from the tureen to the  
(soup) plate.









## QUARTA POSATA



Sono uno Chef, cerco di dare emozione con i gusti, sollecitando i ricordi e ispirando le persone. Ci sono Chef nel mondo che emozionano attraverso il gusto continuamente e lo fanno meglio di me. Uno di questi è Ferran Adrià, cui omaggio l'idea della Quarta Posata, ispirata dalla sua pinza per tapas, oggi cambiata e migliorata per usi nuovi a tavola, insieme ai JRE Italia.

Cucchiaio, Forchetta, Coltello, Quarta Posata. Da oggi possiamo divertirvi di più a tavola!

I'm a Chef, I try to create emotions through taste, soliciting the memories and inspiring people. There are Chefs in the world who continuously create emotions through taste and do it better than me. One of these chefs is Ferran Adrià, who I honor with the idea of the Quarta Posata, inspired by his tapas tongs, today changed and improved for new uses on table thanks to the collaboration with JRE Italy. Spoon, Fork, Knife, Quarta Posata. Starting today, we can have more fun on table!

Je suis un chef, je cherche à créer des émotions à travers le goût, la sollicitation souvenirs et inspirer les gens. Il y a des chefs dans le monde qui créent en permanence des émotions à travers le goût et le faire mieux que moi. L'un de ces chefs est Ferran Adrià, qui je honore avec l'idée de la Quarta Posata, inspiré par ses tapas pinces, a changé aujourd'hui et amélioré pour les nouvelles utilisations sur la table grâce à la collaboration avec JRE Italie.

Cuillère, Fourchette, Couteau, Quarta Posata. A partir d'aujourd'hui, nous pouvons avoir plus de plaisir sur la table !

**JRE**  
JEUNES RESTAURATEURS

Ich bin ein Chef, ich versuche, Emotionen durch Geschmack zu schaffen, das Einholen Erinnerungen und inspirierenden Menschen. Es gibt Chefs in der Welt, die ständig Emotionen durch Geschmack schaffen und es besser ist als ich. Einer dieser Köche ist Ferran Adrià, die ich mit der Idee der Quarta Posata ehren, durch seine Tapas-Zange inspiriert, änderte sich heute und verbessert für neue Nutzungen auf dem Tisch dank der Zusammenarbeit mit JRE Italien.

Löffel, Gabel, Messer, Quarta Posata. Ab heute können wir mehr Spaß auf dem Tisch haben !

Soy un cocinero, trato de crear emociones a través del gusto, solicitando la recuerdos y gente inspiradora. Hay cocineros en el mundo que continuamente crear emociones a través del gusto y lo hacen mejor que yo. Uno de estos chefs es Ferran Adrià, que me honro con la idea de la Quarta Posata, inspirado por sus tapas pinzas, cambió hoy y mejorado para nuevos usos en la tabla gracias a la colaboración con JRE Italia. Cuchara, Tenedor, Cuchillo, Quarta Posata. A partir de hoy, podemos tener más diversión en la mesa !



Marco Stabile







## QUARTA POSATA



**10001129**  
Quarta posata

Lungh. cm. 22,2  
Length 8 3/4"







CHOP STICKS

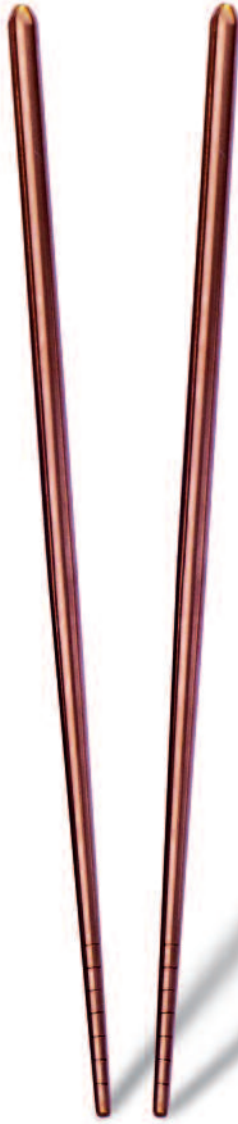

**BRONZO**  
10001128B

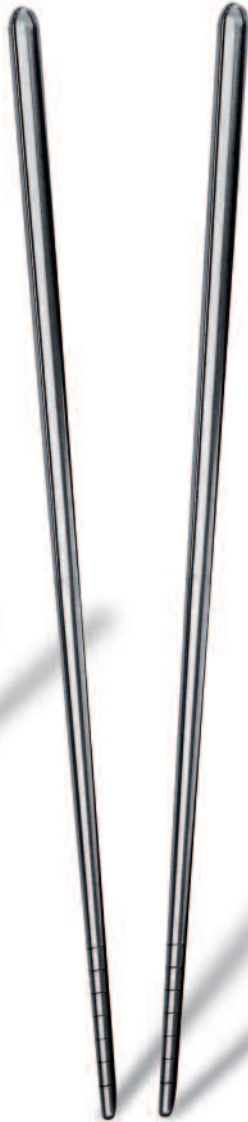

**ACCIAIO**  
10001128



**ORO  
NERO**  
10001128N



**ORO**  
10001128O

**ORO ICE**  
10001128S



**10001175**  
Appoggia chopstick  
Chopstick rest  
Porte chopstick  
Ess-Stäbchen Ablage  
Apoyo para chopstick

Largh. cm. 4,5  
Width 1 3/4"

Paia Chopsticks  
Chopsticks set 2 pcs.  
Paire de chopsticks  
Ess-Stäbchen Paar  
Chopsticks 2 pzas.

cm. 22,5  
8 7/8"







10001109



cm. 22  
8 5/8"

mm. 3,0  
Mestolo  
Ladle  
Louche  
Suppschöpfer  
Cazo sopa

mm. 3,0



cm. 18,5  
7 1/4"

10001116

Pala per torta  
Cake trowel  
Pelle à tarte  
Tortenheber  
Pala tarta

10001142



cm. 20,7  
8 1/8"

mm. 3,0  
Cucchiaione  
da risotto  
Spoon for "Risotto"  
Cuillère à "Risotti"  
Reislöffel  
Cuchara para arroz seco

mm. 2,5



cm. 10,5  
4 1/4"

10001115

Forchettina dolce  
Cake fork  
Fourchette à gateaux  
Kuchengabel  
Tenedor pastel

10001110



cm. 17,5  
6 3/4"

mm. 3,0  
Cucchiaione  
Serving spoon  
Cuillère à servir  
Servierlöffel  
Cuchara servir

mm. 3,0



cm. 15,5  
6"

10001120

Paletta pesce tavola  
Table fish knife  
Couteau poisson  
Fischmesser  
Pala pescado

10001111



cm. 17  
6 5/8"

mm. 3,0  
Forchettone  
Serving fork  
Fourchette à servir  
Serviergabel  
Tenedor servir

mm. 3,0



cm. 15,5  
6"

10001121

Forchetta pesce tavola  
Table fish fork  
Fourchette poisson  
Fischgabel  
Tenedor pescado

10001122



cm. 17  
6 5/8"

mm. 3,0  
Cucchiaio insalata  
Salad serving spoon  
Cuillère à salade  
Salatvorlegelöffel  
Cuchara para ensalada

mm. 3,0



cm. 12,5  
4 7/8"

Happy spoon

10001141

10001122

mm. 2,0



cm. 10,5  
4 1/4"

10001127

Cucchiaino bibita  
Ice tea spoon  
Cuillère à soda  
Limonadenlöffel  
Cucharita refresco

10001123



cm. 17  
6 5/8"

mm. 3,0  
Forchetta insalata  
Salad serving fork  
Fourchette à salade  
Salatvorlegelöffel  
Tenedor para ensalada

mm. 2,5



cm. 8,5  
3 3/8"

10001124

Paletta gelato  
Ice-cream spoon  
Cuillère à glâce  
Eislöffel  
Cucharita helado







BISTECCA



**UNI**  
10001136

Coltello bistecca  
Steak knife  
Couteau entrecôte  
Steakmesser  
Cuchillo bistek  
cm. 21,3  
8 1/4"

**NORMA**  
10101136  
**BOHEME**  
10231136

Coltello bistecca  
Steak knife  
Couteau entrecôte  
Steakmesser  
Cuchillo bistek  
cm. 23  
9 1/8"

**ROMA**  
10141136  
**NATURA**  
10341136  
**MICHELANGELO**  
10201136

Coltello bistecca  
Steak knife  
Couteau entrecôte  
Steakmesser  
Cuchillo bistek  
cm. 22,7  
8 7/8"

**10001145**

Forchetta bistecca  
Steak fork  
Fourchette à entrecôte  
Tranchiergabel  
Tenedor bistek  
cm. 20,3  
8"

**NEW**

**10701136**  
**CARINZIA**

Coltello bistecca  
Steak knife  
Couteau entrecôte  
Steakmesser  
Cuchillo bistek  
cm. 23,1  
9 1/8"

**NEW**

**10711136**  
**STOCCOLMA**

Coltello bistecca  
Steak knife  
Couteau entrecôte  
Steakmesser  
Cuchillo bistek  
cm. 23,1  
9 1/8"



BISTECCA



ACCIAIO

CON LOGO

ORO

ORO ICE

ORO NERO

BRONZO

10001144

10001144O

10001144OS

10001144N

10001144B

**1144**  
 Coltello bistecca americano  
 American steak knife  
 Couteau entrecôte américain  
 Amerikanisches Steakmesser  
 Cuchillo bistek americano  
 cm. 25  
 9 5/8"



ARAGOSTE



**10001140**  
Pinza aragosta  
Lobster pincers  
Pince à homard  
Hummerzange  
Pinzalangostas  
cm. 18,5  
7 1/3"



**10001139**  
Forchetta aragosta  
Lobster fork  
Fourchette langouste  
Hummergabel  
Tenedor langostas  
cm. 19,4  
7 2/3"



**10001143**  
Cucchiaio risotto  
"Risotto" spoon  
Cuillère "Risotto"  
Reislöffel  
Cuchara arroz seco  
cm. 27,7  
11"



**10201143**  
MICHELANGELO  
Cucchiaio risotto  
"Risotto" spoon  
Cuillère "Risotto"  
Reislöffel  
Cuchara arroz seco  
cm. 27,7  
11"



**10001137**  
Coltellino  
Little knife  
Petit couteaux  
Kleine Messer  
Cuchillo pequeño  
cm. 18  
7 1/16"



**10201144**  
Cucchiaino cappuccino  
Cappuccino spoon  
Cuillère cappuccino  
Cappuccinoiöffel  
Cucharita cappuccino  
cm. 16,5  
6 1/2"



**10001150**  
Golf club mixer spoon  
Golf club mixer spoon  
Golf crosse pour  
cocktail  
Golf Schleger für  
Long drink  
Golf club cucharita  
por coctél  
cm. 16,5  
6 1/2"

Modelli-Models  
**POSATE**

LUMACHE



**200779**  
Molla lumache  
Escargot tongs  
Pince escargots  
Schneckenzange  
Pinzas caracoles  
cm. 15,6  
6 1/4"



**10001138**  
Forchetta lumache  
Escargot fork  
Fourchette escargots  
Schnecken-gabel  
Tenedor caracoles  
cm. 14,9  
5 7/8"



**10521131**  
Mini Forchetta  
Appetizer fork  
Fourchette amouse  
bouche  
Minigabel  
Mini tenedor  
cm. 11,4  
4 1/2"



**10521108**  
Mini spoon  
cm. 11,4  
4 1/2"



**10001175**  
Appoggia posate  
Knife rest  
Soutier p/couverts  
Besteck Ablage  
Apoyo p/cubiertos  
Largh. cm. 6,5  
Width 2 1/2"



**10001147**  
Forchetta formaggio  
Cheese fork  
Fourchette fromage  
Käsegabel  
Tenedor queso  
cm. 21  
8 3/8"



**10001125**  
Coltello formaggio  
Cheese knife  
Couteau fromage  
Kaesemesser  
Cuchillo queso  
cm. 22  
8 3/4"



**10001126**  
Coltello parmigiano  
Parmesan chesse knife  
Couteau parmesan  
Parmesanmesser  
Cuchillo parmigiano  
cm. 16,5  
6 1/2"

FORMAGGIO



# Vasellame



HOLLOWARE  
MATERIEL DE SERVICE  
ACCESSOIRES  
ORFEBRERIA

- Gamma completa per tutti gli usi
- Spessore elevato
- Doppia saldatura manici, alta resistenza
- Beccucci rompigoccia
- Prodotti impilabili salvaspazio
- Criterio di progettazione di ogni prodotto accuratamente studiato per il quotidiano uso nel settore alberghiero.
- Each collection offers an extensive range of different items.
- Thicker stainless steel.
- Double welded handles offer durability.
- Drip-less spouts on all pitchers, creamers, coffee and tea pots.
- Space saving stackable items.
- Hospitality grade and professional quality

**MEPRA**  
S.p.A.



- Gamme complète pour tous les us
- Épaisseur massives
- Soudures manches haute résistance
- Becs rompigoutes
- Articles empilables pour sauver space
- Critère de projet de chaque produit est étudié pour l'usage quotidien soigneusement dans le secteur hôtelier

- Ein vollständiges Sortiment für jeden Gebrauch
- Hohe Materialstärke
- Doppelt geschweisste
- Handgriffe, hohe Widerstandsfähigkeit
- Kein Tropfen beim Ausgießen
- Stapelbar und platzsparend
- Jedes Produkt ist genaustens für den täglichen
- Gebrauch in der Spitzengastronomie und -hotellerie gestaltet

- Gamma completa para todos los usos.
- Espesor macizo
- Mango soldado de alta resistencia.
- Vertedor rompe gotas
- Producto apilable ahorra espacio
- Criterio de diseño de cada producto estudiado minuciosamente para el uso cotidiano en el sector hostelero.

**MEPRA**  
S.p.A.









964



mm. 1,2	Vassoio rettangolare con maniglie	cm. 40x27	15 <sup>3</sup> / <sub>4</sub> " x 10 <sup>5</sup> / <sub>8</sub> "
	Rectangular Tray with handles	cm. 45x31	17 <sup>3</sup> / <sub>4</sub> " x 12 <sup>1</sup> / <sub>4</sub> "
	Plateau rectangulaire avec anses	cm. 50x34	19 <sup>5</sup> / <sub>8</sub> " x 13 <sup>3</sup> / <sub>8</sub> "
	Tablett rechteckig mit Griffen	cm. 60x42	23 <sup>5</sup> / <sub>8</sub> " x 16 <sup>1</sup> / <sub>8</sub> "
	Bandeja rectangular con asas		

963GN



mm. 1,2	Vassoio rettangolare gastronomico	cm. 53 x 32,5	20 <sup>3</sup> / <sub>4</sub> " x 12 <sup>2</sup> / <sub>3</sub> "
	Rectangular gastronomic Tray		
	Plateau rectangulaire gastronomico		
	Tablett rechteckig gastronomico		
	Bandeja rectangular gastronomico		

963



mm. 1,2	Vassoio rettangolare	cm. 30x21	11 <sup>3</sup> / <sub>4</sub> " x 8 <sup>1</sup> / <sub>4</sub> "
	Rectangular Tray	cm. 35x24	13 <sup>3</sup> / <sub>4</sub> " x 9 <sup>1</sup> / <sub>2</sub> "
	Plateau rectangulaire	cm. 40x27	15 <sup>3</sup> / <sub>4</sub> " x 10 <sup>5</sup> / <sub>8</sub> "
	Tablett rechteckig	cm. 45x31	17 <sup>3</sup> / <sub>4</sub> " x 12 <sup>1</sup> / <sub>4</sub> "
	Bandeja rectangular	cm. 50x34	19 <sup>5</sup> / <sub>8</sub> " x 13 <sup>3</sup> / <sub>8</sub> "
		cm. 60x42	23 <sup>5</sup> / <sub>8</sub> " x 16 <sup>1</sup> / <sub>8</sub> "

966



mm. 1,2	Vassoio tondo	Ø cm. 13	Ø 5 1/8"
	Round Tray	Ø cm. 19	Ø 7 1/2"
	Plateau rond	Ø cm. 24	Ø 9 1/2"
	Tablett rund	Ø cm. 27	Ø 10 5/8"
	Bandeja redonda	Ø cm. 35	Ø 13 3/4"
		Ø cm. 40	Ø 15 3/4"

965



mm. 1,2	Vassoio rettangolare con piedini	cm. 30x21	11 <sup>3</sup> / <sub>4</sub> " x 8 <sup>1</sup> / <sub>4</sub> "
	Rectangular Tray with feet	cm. 35x24	13 <sup>3</sup> / <sub>4</sub> " x 9 <sup>1</sup> / <sub>2</sub> "
	Plateau rectangulaire avec socles	cm. 40x27	15 <sup>3</sup> / <sub>4</sub> " x 10 <sup>5</sup> / <sub>8</sub> "
	Tablett rechteckig mit Füßen	cm. 45x31	17 <sup>3</sup> / <sub>4</sub> " x 12 <sup>1</sup> / <sub>4</sub> "
	Bandeja rectangular con 4 pies	cm. 50x34	19 <sup>5</sup> / <sub>8</sub> " x 13 <sup>3</sup> / <sub>8</sub> "
		cm. 60x42	23 <sup>5</sup> / <sub>8</sub> " x 16 <sup>1</sup> / <sub>8</sub> "

967



mm. 1,2	Vassoio tondo con piedini	Ø cm. 27	Ø 10 5/8"
	Round Tray with feet	Ø cm. 35	Ø 13 3/4"
	Plateau rond avec socles	Ø cm. 40	Ø 15 3/4"
	Tablett rund mit Füßen		
	Bandeja redonda con 4 pies		



950



mm. 1,2	Ciotola con base	Ø cm. 14	cl. 60	Ø 5 1/2"	oz. 201/4
	Bowl with base	H cm. 8,8		H 3 1/2"	
	Bol avec socle	Ø cm. 20	lt. 1,8	Ø 7 7/8"	oz. 607/8
	Obstschale auf Fuss	H cm. 11		H 4 1/2"	
	Cuenco con pedestal	Ø cm. 24	lt. 3,1	Ø 9 1/2"	oz. 1047/8
		H cm. 14		H 5 1/2"	
	Ø cm. 28	lt. 5,1	Ø 11"	gal. 11/4	
	H cm 16		H 6 1/3"		

977



mm. 1,2	Porta pasticcini	Ø cm 13	Ø 5 1/8"
	Petit-fours stand	H cm 10,5	H 4 1/8"
	Porte-petit fours		
	Petits Fours-Ständer	Ø cm 19	Ø 7 1/2"
	Porta dulces	H cm 14	H 5 1/2"

981/A



mm. 1,2	Alzata portafrutta rettang. 2 piani	cm 35x24	13 3/4" x 9 1/2"
	Rectangular fruit holder 2 layers	cm 45x31	17 3/4" x 12 1/4"
	Serviteur rectangulaire 2 etages	H cm 50	H 19 5/8"
	Etagere, rechteckig 2-stufig		
	Frutero rectangular 2 pisos		

981/B



mm. 1,2	Alzata portafrutta rettang. 3 piani	cm 35x24	13 3/4" x 9 1/2"
	Rectangular fruit holder 3 layers	cm 45x31	17 3/4" x 12 1/4"
	Serviteur rectangulaire 3 etages	cm 60x42	25 5/8" x 16 1/8"
	Etagere, rechteckig 3-stufig	H cm 73	H 28 3/4"
	Frutero rectangular 3 pisos		



978



mm. 1,2	Porta pasticcini a 2 piani	Ø cm. 13	Ø 5 1/8"
	Petit-fours stand 2 layers	Ø cm. 19	Ø 7 1/2"
	Porte-petit fours 2 etages	H cm. 29	H 11 3/8"
	Mokkaétagère 2 Ebenen		
	Porta dulces 2 pisos		

97803



mm. 1,2	Porta pasticcini a 3 piani	Ø cm 13	Ø 5 1/8"
	Petit-fours stand 3 layers	Ø cm 19	Ø 7 1/2"
	Porte-petit fours 3 etages	Ø cm 27	Ø 10 3/8"
	Mokkaétagère 3 Ebenen	H cm 36	H 14 1/4"
	Porta dulces 3 pisos		

980/B



mm. 1,2	Alzata portafrutta tonda 3 piani	Ø cm 27	Ø 10 5/8"
	Round fruit holder 3 layers	Ø cm 35	Ø 13 3/4"
	Serviteur rond 3 etages	Ø cm 40	Ø 15 3/4"
	Etagere, rund 3-stufig	H cm 73	H 28 3/4"
	Frutero redondo 3 pisos		

980/A



mm. 1,2	Alzata portafrutta tonda 2 piani	Ø cm 27	Ø 10 5/8"
	Round fruit holder 2 layers	Ø cm 35	Ø 13 3/4"
	Serviteur rond 2 etages	H cm 50	H 19 5/8"
	Etagere, rund 2-stufig		
	Frutero redondo 2 pisos		



959



960

Coppa in vetro con piedistallo  
Glass bowl with base  
Coupe ronde en verre a/socle  
Glassobstschale rund auf Fuß  
Cuenco redondo en vidrio con pedestal

Ø cm 21,5	Ø 8 1/2"
H cm 29	oz. 91 3/8
cl. 270	H 11 3/8"
Ø cm 12	Ø 4 3/4"
H cm 17	H 6 3/4"
cl. 45	oz. 15 1/4

958



Coppa multiservizio  
Glass bowl with sauce cap  
Coupe multifonctions  
Universalschale  
Ensaladera multiservicio

Ø cm 28	Ø 11"
H cm. 14	H 5 1/2"
cl. 300	oz. 101 1/2

961



Piatto quadro in vetro con piedistallo  
Square glass plate with base  
Plateau carré en verre a/socle  
Obstchale, quadratisch, auf Fuss  
Plato cuadrado en vidrio con pedestal

cm. 24,5x24,5	9 5/8" x 9 5/8"
H cm 17	H 6 3/4"

962



Piatto da torta in vetro con piedistallo  
Glass cake plate with base  
Plat pour gateau en verre a/socle  
Kuchenplatte aus Glas auf Fuss  
Plato para tarta en vidrio con pedestal

Ø cm 33	Ø 12 3/4"
H cm 16	H 6 1/4"

938



mm. 1,2 Vassoio ovale  
Oval tray  
Plateau oval  
Tablett oval  
Bandeja oval

cm. 31 x 22	12 1/8" x 8 3/4"
-------------	------------------

937



mm. 1,2 Cestino per pane  
Oval basket  
Corbeille oval  
Brotkorb oval  
Frutero oval

cm. 31 x 22	12 1/8" x 8 3/4"
lt. 1,7	oz. 57 1/2



968



mm. 2,0	Ampolla e formaggera	cl. 22	cl. 20
	Cruet and cheese basin	H cm 15	
	Huillière et fromagère		
	Essig-Ölflasche und Käsedose	oz. 7 1/2	oz. 6 <sup>3</sup> / <sub>4</sub>
	Vinagrera y quesera	H 5 7/8"	

969



mm. 2,0	Salino e porta stuzzicadenti	cl. 8	cl. 7
	Salt-cellar and toothpick container	H cm. 9	H cm 7
	Salière et porte cure-dents		
	Salzstreuer und Zahnstocherbehälter	oz. 2 3/4	oz. 2 3/8
	Salero y palillero	H 3 1/2"	H 2 3/4"

971

975



mm. 1,2	Chillcup	cl. 15	oz. 5 <sup>1</sup> / <sub>8</sub>
	Caviar dish	H cm 19	H 7 <sup>1</sup> / <sub>2</sub> "
	Bol à caviar		
	Chillcup / Kaviarschale		
	Bol para caviar		

976



mm. 1,2	Servizio per antipasto	Ø cm. 20	Ø 7 7/8"
	Snack server	H cm 15	H 5 7/8"
	Support à snacks	cl. 15 (x3)	oz. 5 <sup>1</sup> / <sub>8</sub> (x3)
	Relish-Pickles-Gestell		
	Entremesera		

935



mm. 1,2	Porta macaron	Ø cm 15	Ø 5 7/8"
	Macarons server	H cm 10	H 4"
	Porte macarons		
	Macaronsträger		
	Porta macaron		

976S



mm. 1,2	Portasalatini impilabile	Ø cm. 20	Ø 7 7/8"
	Stackable snack server	cl. 15 (x3)	oz. 5 <sup>1</sup> / <sub>8</sub> (x3)
	Support à snack empilable		
	Stapelbare Relish-Pickles-Gestell		
	Servicio por entremes impilable		
	<b>976C</b>	<b>Ø cm. 20</b>	<b>Ø 7 7/8"</b>
		<b>H cm 15</b>	<b>H 5 7/8"</b>
		<b>cl. 15 (x3)</b>	<b>oz. 5<sup>1</sup>/<sub>8</sub> (x3)</b>



951



mm. 1,2	Caffettiera con piedistallo	Tazze	4	cl 34	oz 12 <sup>1</sup> / <sub>3</sub>
	Coffee pot with base	Cups	6	cl 52	oz 17 <sup>2</sup> / <sub>3</sub>
	Cafetière avec socle	Bols			
	Kaffekanne auf Fuss	Tassen			
	Cafetera con pedestal	Tazas			

952



mm. 1,2	Teiera con piedistallo	Tazze	2	cl 37	oz 13
	Tea pot with base	Cups	6	cl 60	oz 21
	Théière avec socle	Bols			
	Teekanne auf Fuss	Tassen			
	Tetera con pedestal	Tazas			

953



mm. 1,2	Lattiera con piedistallo	Tazze	2	cl 24	oz 8
	Milk jug with base	Cups	4	cl 34	oz 12 <sup>1</sup> / <sub>3</sub>
	Pot à lait avec socle	Bols			
	Milchkanne auf Fuss	Tassen			
	Jarra lechera con pedestal	Tazas			

954



mm. 1,2	Zuccheriera con piedistallo	Tazze	6	cl 27	oz 10
	Sugar bowl with base	Cups			
	Sucrier avec socle	Bols			
	Zuckerdose auf Fuss	Tassen			
	Azucarero con pedestal	Tazas			

957



mm. 1,2	Portabustine da zucchero	Ø cm 7	Ø 2 3/4"
	Sugar packet holder	H cm 9,5	H 3 3/4"
	Pot à sucre		
	Zuckerstangengefäß		
	Azucarera		

982



mm. 1,2	Alzata portafrutta	Ø cm 27	Ø 10 5/8"
	Fruit holder	H cm. 15	H 5 7/8"
	Serviteur		
	Obstschale		
	Frutero		



247

247



mm. 0,8  
 Cloche con pomolo  
 Cloche with knob  
 Cloche  
 Teller cloche  
 Tapa con pomo

Ø cm. 10,5	Ø 4 1/16"
Ø cm. 13	Ø 5 1/16"
Ø cm. 20	Ø 7 7/8"
Ø cm. 22	Ø 8 5/8"
Ø cm. 24	Ø 9 1/2"
Ø cm. 26	Ø 10 1/4"
Ø cm. 28	Ø 11"
Ø cm. 31	Ø 12 1/8"
Ø cm. 32	Ø 12 5/8"

984



**984**  
 Ø cm 22  
 H.cm.45  
**985**  
 Ø cm 18  
 H.cm.33  
**989**  
 Ø cm 30  
 H.cm.52

**984**  
 Ø 8<sup>13</sup>/<sub>16</sub>"  
 H 17<sup>1</sup>/<sub>4</sub>"  
**985**  
 Ø 7 1/8"  
 H 13"  
**989**  
 Ø 11 3/4"  
 H 20<sup>1</sup>/<sub>2</sub>"

**98402**  
 Ø cm 22  
 H cm.35  
 Ø 8<sup>13</sup>/<sub>16</sub>"  
 H 13 3/4"

Alzata portapiatti  
 Afternoon tea stand  
 Présentoir à gateau  
 Dessert-Serviergestell  
 Soporte platos

mm. 1,2  
 Presentoire  
 2 misure  
 2 sizes  
 2 tailles  
 2 Größen  
 2 tamaños

974

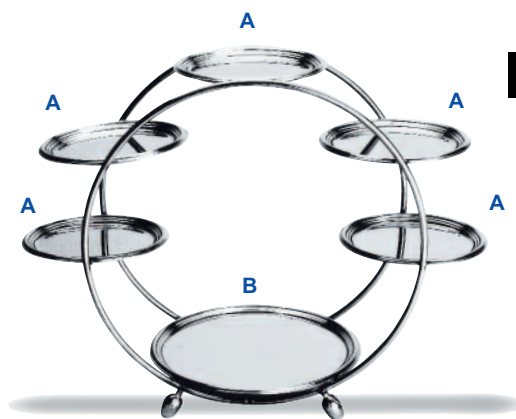

<b>A</b> Ø cm.13 (x5)	<b>A</b> Ø 5 1/8" (x5)
<b>B</b> Ø cm.19	<b>B</b> Ø 7 1/2"
<b>A</b> Ø cm.19 (x5)	<b>A</b> Ø 7 1/2" (x5)
<b>B</b> Ø cm.27	<b>B</b> Ø 10 5/8"

7092



7092

Candelabro a 1 fiamma  
 Candlestick  
 Chandelier  
 Leuchter 1-flammig  
 Candelabro

Silverplated  
 H cm. 28,5  
 H 11 1/4"

7093



Candelabro a 3 fiamme  
 Candelabra, 3 arms  
 Chandelier 3 flammes  
 Leuchter 3-flammig  
 Candelabro 3 luces

Silverplated  
 H cm. 34,5  
 H 13 5/8"

7094



Candelabro a 5 fiamme  
 Candelabra, 5 arms  
 Chandelier 5 flammes  
 Leuchter 5-flammig  
 Candelabro 5 luces

Silverplated  
 H cm. 34,5  
 H 13 5/8"

7094



972



972

mm. 1,2  
**972-972P**  
 Secchiello per ghiaccio  
 Ice bucket  
 Seau à glaçons  
 Eisgefäß  
 Cubitera hielo

Ø cm 15  
 H cm 18  
 cl.150

Ø 5 7/8"  
 H 7 1/8"  
 oz. 50 3/4



973



973P

mm. 1,2  
**973-973P**  
 Secchiello per spumante  
 Sparkling wine cooler  
 Seau à champagne  
 Wein- und Sektkühler  
 Cubo para champany

Ø cm 20,5  
 H cm 24,5  
 cl.500

Ø 8 1/8"  
 H 9 5/8"  
 gal. 1 1/3



972P

666F

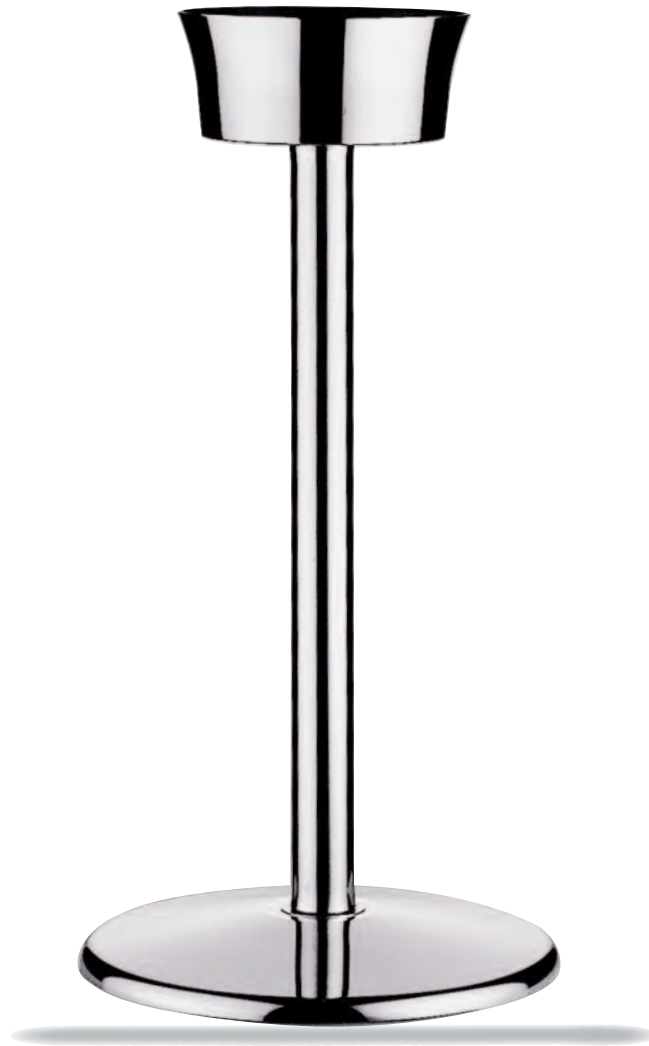

mm. 1,2  
**Colonna portasecchiello spumante**  
 Wine cooler stand w/weighted base  
 Pied pour seau à champagne  
 Weinkühlerständer  
 Columna porta cubo champany

H cm. 67,5 | H 26 5/8"

657



mm. 0,8	Coppa per champagne con inserto Champagne bowl with insert Vasque a champagne avec anneau porte-verre Champagner Bowl mit Gläser - Flaschenring Copa para champagne con anillo	Ø cm. 38 H cm. 29,5 lt. 15	Ø 15" H 11 5/8" gal. 4
---------	--	----------------------------------	------------------------------

949



mm. 1,2	Supporto per informazioni o menu Menu / Card holder Porte nom numéro de table Karten-Speisekartenhalter Porta informaciones o menu	Ø cm. 10 H cm. 10	Ø 4" H 4"
---------	--	----------------------	--------------

986



mm. 0,8	Alzata per crudité rettangolare Rectangular seafood presentation Serviteur à poisson crude rectang. Etagere, rech., für marinierte Fisch Porta pescado rectangular	cm. 53 x 32,5 H cm. 9 lt. 9,0	20 3/4" x 12 2/3" H 3 1/2" gal. 2
---------	--	-------------------------------------	---

995



mm. 2,0	Portanumero Table number stand Numbers etched to order Porte numéro de table Tischnummernständer Porta numero de mesa	A Ø cm 13 H cm 54	A Ø 5 1/8" H 21 1/4"
		B Ø cm 13 H cm 30	B Ø 5 1/8" H 11 7/8"

987



mm. 0,8	Alzata per crudité rettangolare Elevated rectangular seafood presentation Serviteur à poisson crude rectang. Etagere, rech., für marinierte Fisch Porta pescado rectangular	cm. 53 x 32,5 H cm. 25,8 lt. 9,0	20 3/4" x 12 2/3" H 10 1/7" gal. 2
---------	---	--	--

253



983

mm. 0,8	Rinfrescatore con piedini Yogurt cooler with feet Rafrachisseur à yaourts a/socles Yoghurtkühler mit Füßen Refrigerador para yogurt con pies	Ø cm 35 H cm. 12 lt. 2,0	Ø 13 3/4" H 4 3/4" oz. 67 3/5
---------	--	--------------------------------	-------------------------------------



944



mm. 1,2	Zuppiera	Ø cm. 14 - lt. 0,6	Ø 5 1/2" - oz. 20 1/4
	Soup tureen	Ø cm. 18 - lt. 1,2	Ø 7" - oz. 40 5/8
	Soupière	Ø cm. 20 - lt. 1,8	Ø 7 7/8" - oz. 60 7/8
	Suppenterrine	Ø cm. 22 - lt. 2,5	Ø 8 5/8" - oz. 84 1/2
	Sopera	Ø cm. 24 - lt. 3,1	Ø 9 1/2" - oz. 104 7/8
		Ø cm. 26 - lt. 3,9	Ø 10 1/4" - oz. 131 7/8
		Ø cm. 28 - lt. 5,1	Ø 11" - gal. 1 1/4

945



mm. 1,2	Legumiera	Ø cm. 14 - lt. 0,6	Ø 5 1/2" - oz. 20 1/4
	Vegetable dish	Ø cm. 18 - lt. 1,2	Ø 7" - oz. 40 5/8
	Lègumiere	Ø cm. 20 - lt. 1,8	Ø 7 7/8" - oz. 60 7/8
	Lègumier	Ø cm. 22 - lt. 2,5	Ø 8 5/8" - oz. 84 1/2
	Legumbrera	Ø cm. 24 - lt. 3,1	Ø 9 1/2" - oz. 104 7/8
		Ø cm. 26 - lt. 3,9	Ø 10 1/4" - oz. 131 7/8
		Ø cm. 28 - lt. 5,1	Ø 11" - gal. 1 1/4

946



mm. 1,2	Coperchio per art. 944 - 945	Ø cm. 14	Ø 5 1/2"
	Lid for art. 944 - 945	Ø cm. 18	Ø 7"
	Couvercle pour art. 944 - 945	Ø cm. 20	Ø 7 7/8"
	Deckel für art. 944 - 945	Ø cm. 22	Ø 8 5/8"
	Tapa para art. 944 - 945	Ø cm. 24	Ø 9 1/2"
		Ø cm. 26	Ø 10 1/4"
		Ø cm. 28	Ø 11"

936



Cloche trasparente con pomolo	Ø cm 28	Ø 11"
Transparent cloche with knob		
Cloche transparente		
Transparente Teller cloche		
Tapa transparente		

940



939

mm. 1,2	Servizio per caffè macchiato	H cm 18	H 7 1/8"
	Café au lait set	cl. 102	oz. 34
	Service pour café au lait		
	Café au lait-Set		
Juego café au lait			

940/5



mm. 1,2	Servizio per caffè macchiato	H cm 18	H 7 1/8"
	5pcs Sugar, milk and coffee set	cl. 15 (x5)	oz. 5 1/8 (x5)
	Service sucre, lait et café 5 pièces		
	Milch-Kaffee-Zucker Set 5-Tlg.		
Juego leche, café y azucar 5 piezas			

943



mm. 1,2 | Spargisale, portastecchi  
Salt & Pepper  
Sel-poivre/porte cure-dents  
Salz-Pfeffer-Zahnstocherbehälter  
Saleros y pimentero y palillero

H cm. 15 | H 5 7/8"  
cl. 7,5 (x 2) | oz. 2 1/2 (x 2)

988



mm 1,2 | Portamarmellata a 3 scomparti  
Jam pack holder 3 compartment  
Porte-confiture 3 comp.  
Marmeladgestell 3 Einsätze  
Marmeladero 3 comp.

H. cm. 15 | H 5 7/8"  
cl. 28 (x3) | oz. 9 1/2 (x3)

942



mm. 1,2 | Oliera  
Cruet  
2 pièces huile-vinaigre  
Essig-/Ölgestell  
Vinagreras

H cm. 22 | H 8 5/8"  
cl. 22,5 (x 2) | oz. 7 1/2 (x 2)

947

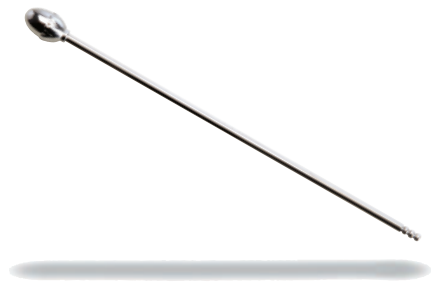

Versatore per profumo a goccia  
Perfume drops dispenser  
Verseur de parfum en gouttes  
Tropf-Parfüm Aussteller  
Versador de perfume en gotas

Lungh. cm 18,5 | Length 7 5/8"

940/3



940/4

mm. 1,2 | Servizio per zucchero 3 e 4 pezzi  
Sugar set 3 and 4 pcs.  
Service pour sucre 3 et 4 pièces  
Sahne-/Zucker-Set 3- und 4-Tlg  
Juego azucar 3 y 4 piezas

H cm. 15 | H 5 7/8"  
cl. 15 (x3) | oz. 5 1/8 (x3)  
cl. 15 (x4) | oz. 5 1/8 (x4)

NEW

922



mm. 1,2 | Mini burriera con coperchio  
Small butter dish w/lid  
Petit beurrier a/couvercle  
Mini Butterdose m/Deckel  
Platillo para mantequilla  
con tapa

cm. 12 x 6 | 4 3/4" x 2 1/3"  
cl. 15 | oz. 5 1/8





257



mm. 1,2	Porta pasticcini con piedistallo	Ø cm. 14	Ø 5 1/2"
	Petit-fours stand with base	H cm. 8,7	H 3 1/2"
	Porte-petits-fours avec socle	Ø cm. 20	Ø 7 7/8"
	Petits Fours-Ständer	H cm. 13	H 5 1/8"
Porta dulces con pedestal	Ø cm. 28	Ø 11"	
	H cm. 14,5	H 5 3/4"	

258



mm. 1,2	Porta pasticcini con piedistallo	Ø cm. 14	Ø 5 1/2"
	Petit-fours stand with legs	Ø cm. 20	Ø 7 7/8"
	Porte-petits-fours avec socle	Ø cm. 28	Ø 11"
	Mokkaétagère 3 Ebenen	H cm. 27	H 10 5/8"
Porta dulces con pedestal			

220



NEW

mm. 1,2	Coppa per punch	Ø cm. 38	Ø 15"
	Punch bowl	H cm. 32,3	H 11 5/8"
	Bol à punch	lt. 15	gal. 4
	Punch Bowl		
Ponchera			

255

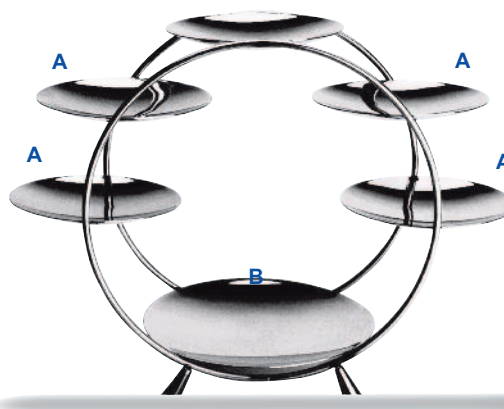

mm. 1,2	Presentoire	<b>25514</b>	<b>25514</b>
	3 misure	A Ø cm.14 (x5)	A Ø 5 1/2" (x5)
	3 sizes	B Ø cm.20	B Ø 7 7/8" (x5)
	3 tailles	<b>25520</b>	<b>25520</b>
3 Größen	A Ø cm.20 (x5)	A Ø 7 7/8" (x5)	
3 tamaños	B Ø cm.24	B Ø 9 1/2" (x5)	
	<b>25524</b>	<b>25524</b>	
	A Ø cm.24 (x5)	A Ø 9 1/2" (x5)	
	B Ø cm.28	B Ø 11"	

7060



7060

7071

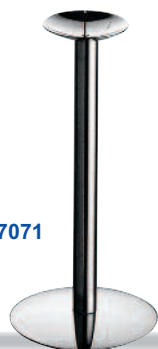

7072



7073



Candelabro bugia  
Candlestick  
Chandelier  
Leuchter mit Kerze  
Candelabro

H cm. 13  
H 5 1/8"

Candelabro a 1 fiamma  
Candlestick  
Chandelier  
Leuchter 1-flammig  
Candelabro

H cm. 23,6  
H 9 1/4"

Candelabro a 3 fiamme  
Candelabra, 3 arms  
Chandelier 3 flammes  
Leuchter 3-flammig  
Candelabro 3 luces

H cm. 23,6  
H 9 1/4"

Candelabro a 5 fiamme  
Candelabra, 5 arms  
Chandelier 5 flammes  
Leuchter 5-flammig  
Candelabro 5 luces

H cm. 23,6  
H 9 1/4"



141



mm. 1,2	Vassoio NOVECENTO	cm. 30 x 21	11 3/4" x 8 1/4"
	Tray »	cm. 35 x 24	13 3/4" x 9 1/2"
	Plateau »	cm. 40 x 27	15 3/4" x 10 5/8"
	Tablett »	cm. 45 x 31	17 3/4" x 12 1/4"
	Bandeja »	cm. 50 x 34	19 5/8" x 13 3/8"
		cm. 60 x 42	23 5/8" x 16 1/2"
		cm. 80 x 54	31 1/2" x 21 1/4"

144



mm. 1,2	Vassoio con maniglie NOVECENTO	cm. 40 x 27	15 3/4" x 10 5/8"
	Tray with handles »	cm. 45 x 31	17 3/4" x 12 1/4"
	Plateau avec anses »	cm. 50 x 34	19 5/8" x 13 3/8"
	Tablett mit Griffen »	cm. 60 x 42	23 5/8" x 16 1/2"
	Bandeja con asas »	cm. 65 x 53	25 5/8" x 20 7/8"
		cm. 80 x 54	31 1/2" x 21 1/4"

141GN



mm. 1,2	Gastronorm NOVECENTO	1/1	1/1
	"	cm. 53 x 32,5	20 7/8" x 12 2/3"
	"		
	"		
	"	2/1	2/1
		cm. 65 x 53	25 5/8" x 20 7/8"

144GN



mm. 1,2	Gastronorm con maniglie NOVECENTO	1/1	1/1
	Gastronorm with handles »	cm. 53 x 32,5	20 7/8" x 12 2/3"
	Gastronorm avec anses »		
	Gastronorm mit Griffen »		
	Gastronorm con asas »	2/1	2/1
		cm. 65 x 53	25 5/8" x 20 7/8"

146GN



mm. 1,2	Gastronorm NOVECENTO	1/1	1/1
	"	cm. 53 x 32,5	20 7/8" x 12 2/3"
	"		
	"		
	"	2/1	2/1
		cm. 65 x 53	25 5/8" x 20 7/8"

146



mm. 1,2	Vassoio con maniglia sovrapponibile	cm. 30 x 21	11 3/4" x 8 1/4"
	Tray with stackable handles	cm. 35 x 24	13 3/4" x 9 1/2"
	Plateau avec anses empilables	cm. 40 x 27	15 3/4" x 10 5/8"
	Tablett mit stapelbaren Griffen	cm. 45 x 31	17 3/4" x 12 1/4"
	Bandeja con asas empilables	cm. 50 x 34	19 5/8" x 13 3/8"
		cm. 60 x 42	23 5/8" x 16 1/2"
		cm. 80 x 54	31 1/2" x 21 1/4"

137



mm. 1,2	Vassoio quadro NOVECENTO	cm. 60 x 60	23 5/8" x 23 5/8"
	Square tray »		
	Plateau carré »		
	Tablett, quadratisch »		
	Bandeja cuadrada »		

256



mm. 1,2	Vassoio rotondo	GIOTTO	Ø cm. 27	Ø 10 5/8"
	Round tray	»	Ø cm. 35	Ø 13 3/4"
	Plateau rond	»	Ø cm. 40	Ø 15 3/4"
	Tablett rund	»		
	Bandeja redonda	»		

138



mm. 1,2	Vassoio quadro con maniglie NOVECENTO	cm. 60 x 60	23 5/8" x 23 5/8"
	Sqaer tray with handles »		
	Plateau carré avec anses »		
	Tablett, quadratisch mit Griffen »		
	Bandeja cuadrada con asas »		

AIRLINES

140



mm. 1,2	Vassoio per compagnie aeree	ATLAS	cm. 38,5 x 21
	Airlines tray for on board service		15 1/8" x 8 1/4"
	Ideal for aircraft and corporates jets		
	Chariot de service	KSSU	cm. 40,4 x 27,9
	Bordservice -Tablett f. Airlines		15 7/8" x 11"
	Bandeja de servicio para comp. aéreas		

139



mm. 1,2	Vassoio quadr.c/man.sovrappon.	cm. 60 x 60	23 5/8" x 23 5/8"
	Square tray w/stackable handles		
	Plateau carré a/anses empliabes		
	Tablett quadr.m/stapelb. Griffen		
	Bandeja cuadrada c/asas empil.		

250

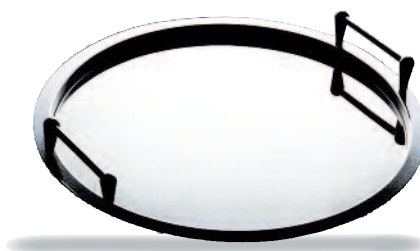

mm. 1,2	Vassoio con maniglia sovrapponibile	Ø cm. 35	Ø 13 3/4"
	Tray with stackable handles	Ø cm. 40	Ø 15 3/4"
	Plateau avec anses empliabes		
	Tablett mit stapelbaren Griffen		
	Bandeja con asas empilables		



295



mm. 1,2	Vassoio tondo con piedistallo	Ø cm. 35	Ø 13 3/4"
	Round tray with base	H cm. 12,5	H 4 7/8"
	Plateau rond avec socle		
	Obstschale, rund auf Fuß		
	Bandeja redonda con pedestal		

297



mm. 1,2	Vassoio ovale con piedistallo	cm. 45 x 30	17 3/4" x 11 3/4"
	Oval tray with base	H cm. 12,5	H 4 7/8"
	Plateau oval avec socle		
	Obstschale, oval auf Fuß		
	Bandeja oval con pedestal		

296



mm. 1,2	Vassoio rettang. con piedistallo	cm. 45 x 30	17 3/4" x 11 3/4"
	Rectangular tray with base	H cm. 12,5	H 4 7/8"
	Plateau rectang. avec socle		
	Tablett, rechteckig auf Fuß		
	Bandeja rectang. con pedestal		

298



mm. 1,2	Piatto torta con piedistallo	Ø cm. 40	Ø 15 3/4"
	Cakes plate with base	H cm. 9,5	H 3 3/4"
	Plat à tarte avec socle		
	Kuchenplatte auf Fuß		
	Bandeja tarta con pedestal		

287



mm. 2,0	Vassoio rettangolare per buffet	cm. 30x21	11 3/4" x 8 1/4"
	Rectangular Tray for buffet	cm. 40x27	15 3/4" x 10 5/8"
	Plateau rectangulaire pour buffet	cm. 50x34	19 5/8" x 13 3/8"
	Buffet -Tablett, rechteckig	cm. 60x42	23 5/8" x 16 1/8"
	Bandeja rectangular para entremes		

288



mm. 2,0	Vassoio tondo per buffet	Ø cm. 30	Ø 11 3/4"
	Round Tray for buffet	Ø cm. 40	Ø 15 3/4"
	Plateau rond pour buffet	Ø cm. 50	Ø 19 5/8"
	Buffet-Tablett rund	Ø cm. 60	Ø 23 5/8"
	Bandeja redondapara entremes		

7004A



mm. 0,8	Alzata per pesce crudo	Ø cm. 34	Ø 13 3/4"
	Marinated fish holder	Ø cm. 41	Ø 16 1/8"
	Serviteur à poisson crude	H cm. 55	H 21 5/8"
	Etagere für marinierten Fisch		
Porta pescado			

7004B



mm. 1,2	Alzata per pesce crudo	Ø cm. 22	Ø 8 5/8"
	Marinated fish holder	Ø cm. 34	Ø 13 3/8"
	Serviteur à poisson crude	H cm. 38	H 15"
	Etagere für marinierten Fisch		
Porta pescado			

7002/B



mm. 1,2	Alzata portafrutta	NOVECENTO	cm. 35x24	13 3/4" x 9 1/2"
	Fruit holder	»	cm. 45x31	17 3/4" x 12 1/4"
	Serviteur	»	cm. 60x42	23 5/8" x 16 1/2"
	Etagere	»	H cm. 70	H 27 5/8"
	Frutero	»		

7001/B



mm. 1,2	Alzata portafrutta	GIOTTO	Ø cm. 27	Ø 10 5/8"
	Fruit holder	»	Ø cm. 35	Ø 13 3/4"
	Serviteur	»	Ø cm. 40	Ø 15 3/4"
	Etagere	»	H cm. 70	H 27 5/8"
	Frutero	»		



67301



67304

mm. 1,2

Portagiaccio termico con coperchio  
Insulated ice-bucket with lid  
Seau à glaçons thermique  
avec couvercle  
Isolier-Eisgefäß, mit Deckel  
Cubitera hielo térmica con tapa

Ø cm 14  
H cm 13,5  
lt. 0,70

Ø cm 24  
H cm 23  
lt. 2,75

Ø 5 1/2"  
H 5 1/9"  
oz. 23 2/3

Ø 9 1/2"  
H 9"  
oz. 93

mm. 1,2



668

Secchiello per spumante  
Sparkling wine cooler  
Seau à champagne  
Wein- und Sektkühler  
Cubo para champany

Ø cm 24  
H cm 23  
lt. 2,75

Ø cm 14  
H cm 13,5  
lt. 0,70

Ø 9 1/2"  
H 9"  
oz. 93

Ø 5 2/3"  
H 5 1/9"  
oz. 23 2/3

666E



mm. 1,2

Colonna portasecchiello spumante  
Wine cooler stand  
Pied pour seau à champagne  
Weinkühlerständer  
Columna porta cubo champany

H cm. 67,5

H 26 5/8"

686



mm. 1,2	Champagnera 5 bott. c/pied. Giant Champagne bucket 5 bot. Seau à champagne p/5 bout. Champagner Bowl 5 Fläsche Cubo de champagne p/5 bot.	Ø cm. 40	Ø 15 3/4"
		H cm. 38,5 lt. 15	H 15 1/6" gal. 4

685



mm. 1,2	Champagnera 5 bott. s/pied. Giant Champagne bucket 5 bot. Seau à champagne p/5 bout. Champagner Bowl 5 Fläsche Cubo de champagne p/5 bot.	Ø cm. 40	Ø 15 3/4"
		H cm. 21,8 lt. 15	H 8 3/5" gal. 4

666I



mm. 1,2	Colonna portabottiglie spumante Wine cooler stand Pied pour seau à champagne Weinkühlerständer Columna porta cubo champany	H cm. 78	H 30 5/7"



265

N E W

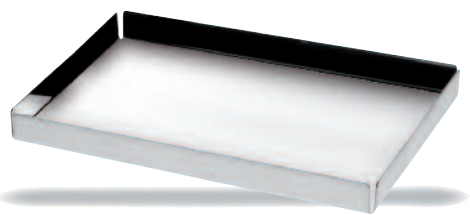

mm. 1,2	Vassoio per pasticceria	cm. 24,5 x 17	9 5/8" x 6 3/4"
	Pâtisserie tray	cm. 30 x 21	11 3/4" x 8 1/4"
	Plateau pour pâtisserie	cm. 34 x 24	13 3/8" x 9 1/2"
	Pâtisserie Tablett		
	Bandeja para pastelería		

516

516

51610



mm. 1,2	Portabustine da zucchero	<b>516</b>	<b>516</b>
	Sugar packet holder	cm. 10 x 7	4" x 2 3/4"
	Pot à sucre	H cm. 3	H 1 1/8"
	Zuckerstangengefäß		
	Azucarera	<b>51610</b>	<b>51610</b>
		cm. 10 x 5	4" x 2"
		H cm. 4,5	H 1 3/4"

206

N E W

205

518

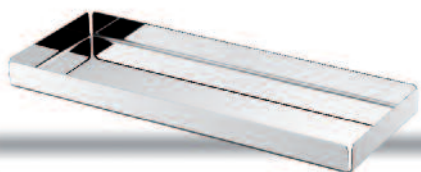

Vassoio per pasticceria  
Pâtisserie tray  
Plateau pour pâtisserie  
Pâtisserie Tablett  
Bandeja para pastelería  
mm. 1,2

cm. 26 x 12  
cm. 60 x 12  
  
10 1/4" x 4 3/4"  
23 3/5" x 10 1/5"

Cesto portapane, porta agrumi  
Basket for bread/ for fruit  
Panier / Porte agrumes  
Brot-/Früchtekorb  
Cesto por pan/ por cítricos  
mm. 1,2

cm. 33 x 26  
H cm. 20  
  
13" x 10 1/5"  
H 7 7/8"

con piedistallo  
with foot  
avec socle  
mit Fuss  
con pies

cm. 26 x 12  
cm. 60 x 12  
H cm. 13  
  
10 1/4" x 4 3/4"  
23 3/5" x 10 1/5"  
H 5 1/8"

704

N E W

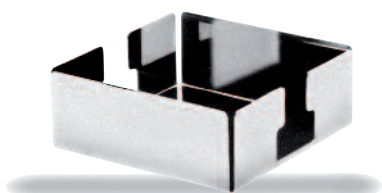

mm. 1,2

Portatovaglioli  
Napkin holder  
Distributeur de serviettes  
Serviettenhalter  
Portaservilletas

cm. 13 x 13

5 1/9" x 5 1/9"

N E W

270



mm. 1,2

Portatovaglioli  
Napkin holder  
Distributeur de serviettes  
Serviettenhalter  
Portaservilletas

cm. 12,5 x 4,5

H cm. 7

5" x 1 7/8"  
H 2 3/4"

143



mm. 1,2 Vassoio  
Tray  
Plateau  
Tablett  
Bandeja

cm. 30,5 x 25,5 12" x 10"

259



mm. 1,2 Ciotola con base  
Bowl with base  
Bol avec socle  
Obstschale auf Fuss  
Cuenco con pedestal

Ø cm. 20  
H cm. 14,3  
lt. 2,1

Ø 5 2/3"  
H 7 7/8"  
gal. 1/2

Ø cm. 28  
H cm. 18,3  
lt. 5,7

Ø 11"  
H 7 1/5"  
gal. 1 1/2

864



GALA  
Cestino semitraforato  
Half fretworked basket  
Corbeille demi-ajouré  
Schale, halbgelocht  
Frutero semiperforado

Ø cm. 22  
H cm. 5,7  
cl. 150

Ø 8 5/8"  
H 2 1/4"  
oz. 50 3/4

mm. 0,8

834



GALA  
Cestino portafrutta  
Round basket  
Corbeille ronde  
Schale, rund  
Frutero redondo

Ø cm. 22  
H cm. 5,7  
cl. 150

Ø cm. 34  
H cm. 5,7  
cl. 500

Ø 8 5/8"  
H 2 1/4"  
oz. 50 3/4

Ø 13 3/8"  
H 2 1/4"  
gal. 1 1/3

mm. 0,8



GALA  
Cestino traforato  
Fretworked basket  
Corbeille ajouré  
Schale, gelocht  
Frutero perforado

Ø cm. 22  
H cm. 5,7  
cl. 150

Ø 8 5/8"  
H 2 1/4"  
oz. 50 3/4

mm. 0,8

863

254



Supporto per informazioni o menu  
Menu / Card holder  
Porte nom numéro de table  
Karten / Speisekartenhalter  
Porta informaciones o menu

Ø cm. 6  
H cm. 9

Ø 2 1/2"  
H 3 1/2"

mm. 0,8



907

Portamenù  
Menù holder  
Porte-menu  
Menükartenhalter  
Portamenu

cm. 21 x 13,5  
H cm 29,7

8 5/8" x 5 3/8"  
H 11 3/4"

mm. 0,8



994

Portanumero  
Table number stand  
Numbers etched to order  
Porte numéro de table  
Tischnummernständer  
Porta numero de mesa

mm. 0,8

**A**  
Ø cm 8,3  
H cm 47,3

**B**  
Ø cm 8,3  
H cm 24

**A**  
Ø 3 1/4"  
H 18 5/8"

**B**  
Ø 3 1/4"  
H 9 1/2"



712



mm. 1,2 | Chillcup per burro e caviale con base  
Chillcup for butter and caviar with base  
Chillcup pour beurre et caviar avec socle  
Chillcup für Butter und Kaviar mit Fuß  
Chillcup para mantequilla y caviar con pedestal

713



Chillcup per burro  
Chillcup for butter  
Chillcup pour beurre  
Chillcup für Butter  
Chillcup para mantequilla

Ø cm. 12  
cl. 150  
Ø 4 3/4"  
oz. 50 3/4



Servizio per caviale  
Caviar set  
Service à caviar complet  
Kaviarschale  
Servicio para caviar

Ø cm. 18  
cl. 150  
Ø 7 1/8"  
oz. 50 3/4

301



301A

301C

301B

mm. 0,8 | Chillcup per cocktail di gamberetti  
Supreme bowl, complete  
Coupe à crevettes  
Chillcup für Hummercocktail  
Chillcup para coctél mariscos

301 Ø cm. 15  
cl. 17,5  
301A Ø cm. 15  
301B Ø cm. 13,5  
301C Ø cm. 9,5  
cl. 17,5

Ø 5 7/8"  
oz. 6  
301A Ø 5 7/8"  
301B Ø 5 3/8"  
301C Ø 3 3/4"  
oz. 6

725

722



mm. 0,6 | Piatino per coppa gelato  
Under liner for ice-cream bowl  
Petit plat soucoupe glace  
Unterteller für Eisschale  
Platillo melado

Ø cm. 12  
Ø 4 3/4"

Coppa per gelato e macedonia  
Ice-cream and salad fruit bowl with stand  
Coupe à glace et macédoine  
Eisfrüchteschale  
Copa helado y macedonia

Ø cm. 8,5  
cl. 15  
Ø 3 3/4"  
oz. 5 1/8

mm. 1,2 | Coppa per gelato  
Ice-cream bowl  
Coupe à glace  
Eisschale  
Copa helado

Ø cm. 9,5  
cl. 17

Ø 3 3/4"  
oz. 6

723



498



mm. 1,2	Completo oliera con spargisale a 5	H cm. 22	H 8 5/8"
	Cruet and salt cellar set 5 pcs.	cl. 22,5 (x 2)	oz. 7 1/2 (x 2)
	Service huile-vinaigre 5 pcs.	cl. 7,5 (x 3)	oz. 2 1/2 (x 3)
	Essig-/Ölgestell 5-Tlg.		
	Convoy vinagreras con saleros 5 pzs		

507



mm. 1,2	Completo oliera con spargisale a 4	H cm. 22	H 8 5/8"
	Cruet and salt cellar set 4 pcs.	cl. 22,5 (x 2)	oz. 7 1/2 (x 2)
	Service huile-vinaigre 4 pcs.	cl. 7,5 (x 2)	oz. 2 1/2 (x 2)
	Essig-/Ölgestell 4-Tlg.		
	Convoy vinagreras con saleros 4 pzs		

506



430502

mm. 1,2	Oliera	GALA	H cm. 22	H 8 5/8"
	Cruet	»	cl. 22,5 (x 2)	oz. 7 1/2 (x 2)
	2 pièces huile-vinaigre	»		
	Essig-/Ölgestell	»		
	Vinagreras	»		

525



mm. 1,2	Formaggera	GALA	cl. 20	oz. 6 3/4
	Parmesan cheese basin	»		
	Fromagère	»		
	Käsedose	»		
	Quesera-Azucarero	»		

513



430502SS

mm. 1,2	Spargisale, portastecchi	GALA	H cm. 15	
	Salt-cellar with toothpick container	»	cl. 7,5 (x 3)	
	Sel/poivre/porte cure-dents	»		
	Salz-Pfeffer-Zahnstocherbehälter	»	H 5 7/8"	
	Saleros y pimentero y palillero	»	oz. 2 1/2 (x 3)	

NEW

702



mm. 1,2	Mini burriera con coperchio	cm. 12 x 6	4 3/4" x 2 1/3"
	Small butter dish w/lid	cl. 15	oz. 5 1/8
	Petit beurrier a/couvercle		
	Mini Butterdose m/Deckel		
	Platillo para mantequilla con tapa		



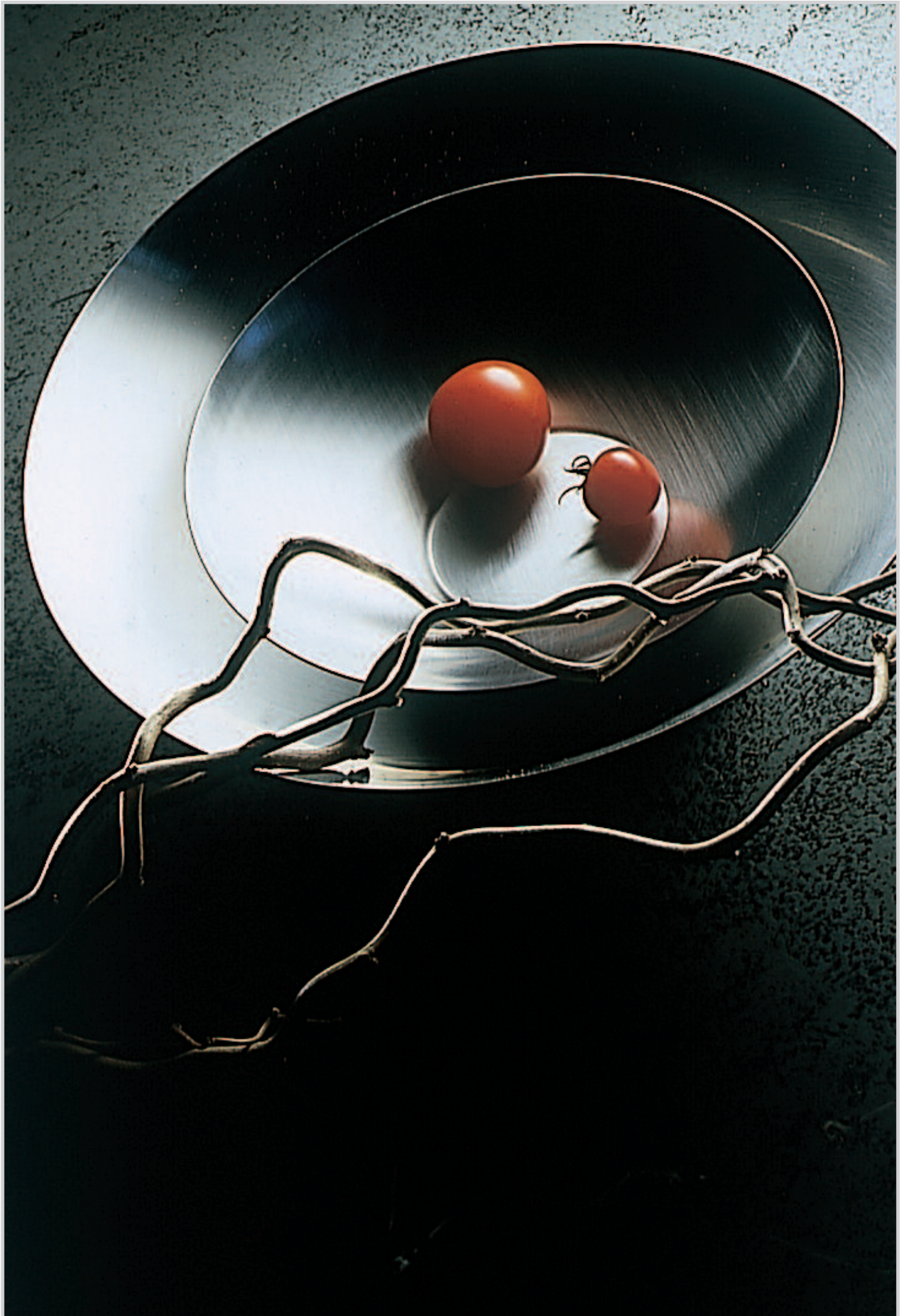

609



mm. 1,2	Piano Tray Plateau Tablett oval Bandeja	cm. 40 x 36	15 3/4" x 14 1/8"
---------	---	-------------	-------------------

612



mm. 1,2	Piano forato Tray fretworked handles Plateau avec anses ajourée Grifftablett oval Bandeja asa perforada	cm. 40 x 36	15 3/4" x 14 1/8"
---------	---	-------------	-------------------

613



mm. 1,2	Fondo Bowl Bol Brotschale oval Cuenco	cm. 22 x 20	8 5/8" x 7 7/8"
		cl. 80	oz. 27
		cm. 40 x 36	15 3/4" x 14 1/8"
		lt. 4,0	gal. 1

614



mm. 1,2	Fondo forato Bowl fretworked handles Bol avec anses ajourée Griffschale oval Cuenco asa perforada	cm. 22 x 20	8 5/8" x 7 7/8"
		cl. 49	oz. 16 1/2
		cm. 40 x 36	15 3/4" x 14 1/8"
		lt. 2,6	oz. 87 7/8

617



mm. 1,2	Sottopiatto ovale Charger oval Assiette de bienvenue ovale Platzteller oval Bajo plato oval	cm. 34 x 31	13 3/8" x 12 1/4"
		cm. 39 x 36	15 3/8" x 14 1/8"

616AC



mm. 1,2	Piattino per pane Bread tray Plat pour pan Brot Platte Plato para pan	cm. 14 x 12	5 1/2" x 4 3/4"
---------	---	-------------	-----------------



561



mm. 1,2	Rettangolare piano	cm. 23 x 13	9" x 5 <sup>1</sup> / <sub>8</sub> "
	Rectangular tray	cm. 38 x 25	15" x 9 <sup>7</sup> / <sub>8</sub> "
	Plateau rectangulaire		
	Tablett, rechteckig		
	Bandeja rectangular		

562



mm. 1,2	Rettangolare fondo	cm. 38 x 25	15" x 9 <sup>7</sup> / <sub>8</sub> "
	Rectangular bowl	H cm. 5,1	H 2"
	Bol rectangulaire	cl. 300	oz. 101 <sup>1</sup> / <sub>2</sub>
	Obstschale, rechteckig		
	Cuenco rectangular		

557



mm. 1,2	Ovale piano	cm. 37 x 25	14 <sup>1</sup> / <sub>2</sub> " x 9 <sup>7</sup> / <sub>8</sub> "
	Oval tray	cm. 46 x 31	18 <sup>1</sup> / <sub>8</sub> " x 12 <sup>1</sup> / <sub>4</sub> "
	Plateau, oval		
	Tablett, oval		
	Bandeja oval		

558



mm. 1,2	Ovale fondo	cm. 37 x 25	14 <sup>1</sup> / <sub>2</sub> " x 9 <sup>7</sup> / <sub>8</sub> "
	Oval bowl	H cm. 6,3	H 2 <sup>1</sup> / <sub>2</sub> "
	Bol oval	cl. 250	oz 84 <sup>1</sup> / <sub>2</sub>
	Obstschale, oval		
	Cuenco oval	cm. 46 x 31	18 <sup>1</sup> / <sub>8</sub> " x 12 <sup>1</sup> / <sub>4</sub> "
		H cm. 6,3	H 2 <sup>1</sup> / <sub>2</sub> "
		cl. 400	gal. 1

563



mm. 1,2	Quadro piano	cm. 15 x 15	5 <sup>7</sup> / <sub>8</sub> " x 5 <sup>7</sup> / <sub>8</sub> "
	Square tray	cm. 22 x 22	8 <sup>5</sup> / <sub>8</sub> " x 8 <sup>5</sup> / <sub>8</sub> "
	Plateau carré		
	Tablett, quadratisch		
	Bandeja cuadrada		

564

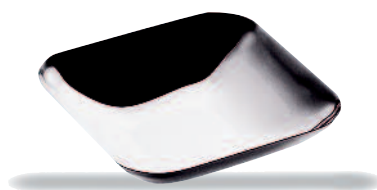

mm. 1,2	Quadro fondo	cm. 15 x 15	5 <sup>7</sup> / <sub>8</sub> " x 5 <sup>7</sup> / <sub>8</sub> "
	Square bowl	H cm. 4,9	H 2"
	Bol carré	cl. 50	oz. 16 <sup>7</sup> / <sub>8</sub>
	Schale, quadratisch		
	Cuenco cuadrado	cm. 22 x 22	8 <sup>5</sup> / <sub>8</sub> " x 8 <sup>5</sup> / <sub>8</sub> "
		H cm. 4,9	H 2"
		cl. 150	oz. 50 <sup>3</sup> / <sub>4</sub>

559



mm. 1,2	Tondo piano Wine bottle coaster Plateau ronde Tablett rund Bandeja redonda	Ø cm. 12	Ø 4 3/4 "
---------	--	----------	-----------

560



mm. 1,2	Tondo fondo Round bowl Bol ronde Obstschale, rund Cuenco redondo	Ø cm. 12 H cm. 3,9 Ø cm. 15 H cm. 5 Ø cm. 22 H cm. 5,8 Ø cm. 32 H cm. 6,8	cl. 26 cl. 60 cl. 131 lt. 3,0	Ø 4 3/4" oz. 8 3/4 H 1 1/2" Ø 5 7/8" oz. 20 1/4 H 2" Ø 8 5/8" oz. 44 1/3 H 2 1/4" Ø 12 5/8" oz. 101 2/5 H 2 2/3"
---------	--	--	--	---

568

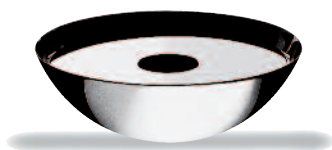

mm. 1,2	Posacenere ad acqua Water ashtray Cendrier à eau Wasserascher rund Cenicero ad agua	Ø cm. 12 cl. 26	Ø 4 3/4 " oz 8 4/5
---------	---	--------------------	-----------------------

569



mm. 1,2	Posacenere ad acqua Water ashtray Cendrier à eau Wasserascher quadrat. Cenicero ad agua	cm. 15 x 15 cl. 50	5 7/8" x 5 7/8" oz 16 7/8
---------	---	-----------------------	------------------------------

567



mm. 1,2	Sottopiatto Charger Assiette de bienvenue Platzteller Bajo plato	cm. 32 x 32	12 5/8" x 12 5/8"
---------	--	-------------	-------------------

N E W

870

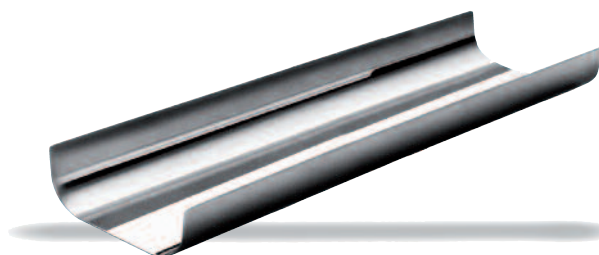

mm. 1,2	GIOTTO Portapane / Portagrissini Bread / Bread sticks holder Porte pan / Porte gressin Brot und-Grissini -Schale Portapan / Porta bastoncillos de pan	cm. 35,5 x 11	14" x 4 1/3"
---------	--	---------------	--------------



596

599



608

mm. 1,2 | Cestini traforati  
Fretworked baskets  
Corbeilles, ajourées  
Früchtekorb gelocht  
Cestas perforadas

**596**  
Ø cm. 16,8  
H cm. 11  
cl. 150

Ø 6 5/8"  
H 4 3/8"  
oz. 50 3/4

**608**  
Ø cm. 27  
H cm. 13,5  
lt. 5

Ø 10 1/2"  
H 5 1/4"  
gal. 1 1/3

**599**  
Ø cm. 29  
H cm. 18,5  
lt. 8

Ø 11 3/8"  
H 7 1/4"  
gal. 2

730



mm. 1,2 | Spumantiera 12 bottiglie champagne  
Giant champagne bucket for 12 bottles  
Seau à champagne géante pour 12 bouteilles  
Champagner Bowl für 12 Flaschen  
Cubo de champagne gigante para 12 botellas

cm. 75 x 65  
H cm. 19  
lt. 15

29 1/2" x 25 5/8"  
H 7 1/2"  
gal. 3 7/8

438

689

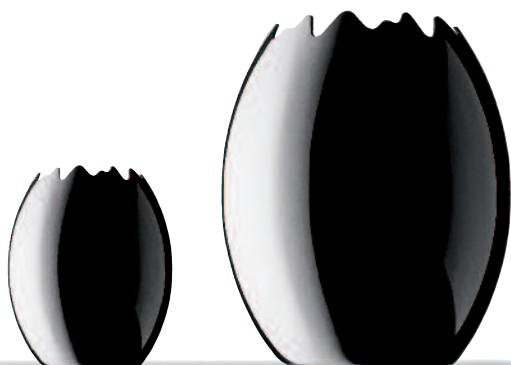

439

mm. 1,2

mm. 1,2  
**OVETTO**  
Secchiello per ghiaccio  
Ice-bucket  
Seau à glaçons  
Eisgefäß  
Cubitera hielo

Ø cm. 11  
H cm. 13  
cl. 100

Ø 4 3/8"  
H 5 1/8"  
oz. 33 7/8

**OVO**  
Secchiello per spumante  
Sparkling wine cooler  
Seau à champagne  
Wein- und Sektkühler  
Cubo para champany

Ø cm. 19  
H cm. 22  
lt. 4,5

Ø 7 1/2"  
H 8 5/8"  
gal. 1 1/4



688

mm. 1,2  
Secchiello per ghiaccio  
Ice-bucket  
Seau à glaçons  
Eisgefäß  
Cubitera hielo

Ø cm. 11  
H cm. 12,5  
cl. 55

Ø 4 3/8"  
H 4 7/8"  
oz. 18 5/8

mm. 1,2  
Secchiello per spumante  
Sparkling wine cooler  
Seau à champagne  
Wein- und Sektkühler  
Cubo para champany

Ø cm. 19  
H cm. 20  
lt. 2,5

Ø 7 1/2"  
H 7 3/4"  
oz. 84 1/2

598



607



597

mm. 1,2 | Cestini  
Baskets  
Corbeilles  
Früchtekorben  
Cestas

**598**  
Ø cm. 29 | Ø 11 3/8"  
H cm. 18,5 | H 7 1/4"  
lt. 8 | gal. 2

**607**  
Ø cm. 27 | Ø 10 1/2"  
H cm. 13,5 | H 5 1/4"  
lt. 5 | gal. 1 1/3

**597**  
Ø cm. 16,8 | Ø 6 5/8"  
H cm. 11 | H 4 3/8"  
cl. 150 | oz. 50 3/4

666C

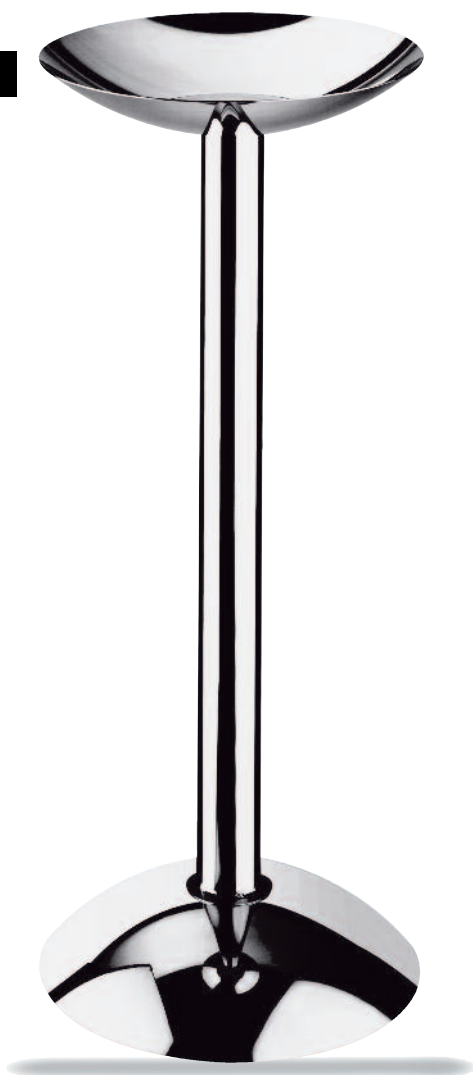

912



909

mm. 1,2  
Secchiello per spumante  
Sparkling wine cooler  
Seau à champagne  
Wein- und Sektkühler  
Cubo para champany

cm. 39 x 36  
H cm. 17,5  
lt. 6  
15 3/8" x 14 1/4"  
H 7"  
gal. 1 3/5

mm. 1,2  
Secchiello per ghiaccio  
Ice-bucket  
Seau à glaçons  
Eisgefäß  
Cubitera hielo

cm. 22 x 20  
H cm. 11,5  
lt. 1,2  
H 4 5/8"  
8 3/4" x 7 7/8"  
oz. 40 1/2

910



899

mm. 1,2 | Colonna portasecchiello spumante UNO | H cm. 65 | H 25 5/8"  
Wine cooler stand »  
Pied pour seau à champagne »  
Weinkühlerständer »  
Columna porta cubo champany »

mm. 1,2  
Secchiello per spumante  
Sparkling wine cooler  
Seau à champagne  
Wein- und Sektkühler  
Cubo para champany

cm. 39 x 36  
H cm. 17,5  
lt. 7  
15 3/8" x 14 1/4"  
H 7"  
gal. 1 4/5

mm. 1,2  
Secchiello per ghiaccio  
Ice-bucket  
Seau à glaçons  
Eisgefäß  
Cubitera hielo

cm. 22 x 20  
H cm. 11,5  
lt. 1,6  
8 3/8" x 7 7/8"  
H 4 5/8"  
oz. 54



570



mm. 1,2 | Cremiera  
Cream jug  
Crémier  
Sahnegießer/Milchkännchen  
Jarrita lechera

Ø cm. 6 | Ø 2 3/8"  
H cm. 8,8 | H 3 1/2"  
cl. 16 | oz 5 3/8

571



mm. 1,2 | Zuccheriera  
Sugar bowl  
Sucriere  
Zuckerdose  
Azucarero

Ø cm. 9,5 | Ø 3 3/4"  
H cm. 6,8 | H 2 3/4"  
cl. 20 | oz 6 3/4

514

NEW

514S

514P



mm. 0,8 | GIOTTO  
Spargisale e Spargipepe  
Salt and pepper cellar  
Salière et poivrère  
Salz und Pepper-streuer  
Salero y pimentero

Ø cm. 3 | Ø 1 1/6"  
H cm. 3 | H 1 1/6"  
cl. 5 | oz. 1 2/3

999C

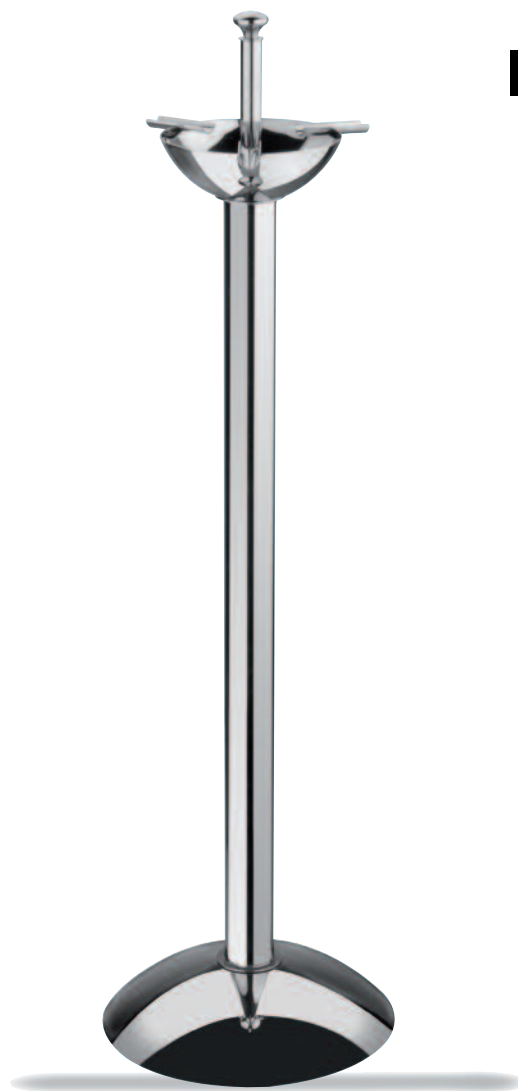

719

NEW



mm. 1,2 | Bicchiere termico  
Insulated shot glass  
Shot-verre thermique  
Warmhalter Shot Glass  
Vaso térmico por chupito

Ø cm. 5 Est. | Ø 2" Out.  
Ø cm. 4 Int. | Ø 1 3/5" Ins.  
H cm. 6,3 | H 2 1/2"  
cl. 6 | oz. 2

mm. 1,2 | Posacenere a colonna  
Ashtray column  
Borne étouffoir  
Ascherständer  
Cenicero à columna

H cm 91,5 | H 36"

26202



mm. 1,2	Centrotavola/Fruttieria ovale 2p	cm. 46 x 31	18 <sup>1</sup> / <sub>8</sub> " x 12 <sup>1</sup> / <sub>4</sub> "
	Elevated centerpiece/Fruit-bowl	cm. 37 x 25	14 <sup>1</sup> / <sub>2</sub> " x 9 <sup>7</sup> / <sub>8</sub> "
	Centre de table/Compotier	H cm. 28	H 11 <sup>1</sup> / <sub>8</sub> "
	Tafelaufsatz/Obstschale	lt. 6,5	gal. 1 <sup>5</sup> / <sub>7</sub>
Centro de mesa/Fruterio			

242



mm. 1,2	Centrotavola/Fruttieria tonda	Ø cm.32	Ø 12 <sup>5</sup> / <sub>8</sub> "
	Elevated centerpiece/Fruit-bowl	H cm. 19	H 7 <sup>1</sup> / <sub>2</sub> "
	Centre de table/Compotier	lt. 3,0	oz. 101 <sup>2</sup> / <sub>5</sub>
	Tafelaufsatz/Obstschale		
Centro de mesa/Fruterio			

26203



mm. 1,2	Centrotavola/Fruttieria ovale 3p	cm. 46 x 31	18 <sup>1</sup> / <sub>8</sub> " x 12 <sup>1</sup> / <sub>4</sub> "
	Elevated centerpiece/Fruit-bowl	cm. 37 x 25	14 <sup>1</sup> / <sub>2</sub> " x 9 <sup>7</sup> / <sub>8</sub> "
	Centre de table/Compotier 3et.	Ø cm. 12	Ø 4 <sup>3</sup> / <sub>4</sub> "
	Tafelaufsatz/Obstschale 3-Stu.	H cm. 37	H 14 <sup>1</sup> / <sub>2</sub> "
Centro de mesa/Fruterio 3pisos	lt. 6,7	gal. 1 <sup>3</sup> / <sub>4</sub>	

24202



mm. 1,2	Centrotavola/Fruttieria tonda 2 piani	Ø cm. 32	Ø 12 <sup>5</sup> / <sub>8</sub> "
	Elevated centerpiece/Fruit-bowl 2t	Ø cm. 22	Ø 8 <sup>5</sup> / <sub>8</sub> "
	Centre de table/Compotier 2 et.	H cm. 29,5	H 11 <sup>3</sup> / <sub>5</sub> "
	Tafelaufsatz/Obstschale 2-Stufig	lt. 4,3	gal. 1 <sup>1</sup> / <sub>8</sub>
Centro de mesa/Fruterio 2 pisos			

26204



mm. 1,2	Centrotavola/Fruttieria ovale 4p	cm. 55 x 24	21 <sup>5</sup> / <sub>8</sub> " x 9 <sup>1</sup> / <sub>2</sub> "
	Elevated centerpiece/Fruit-bowl	cm. 46 x 31	18 <sup>1</sup> / <sub>8</sub> " x 12 <sup>1</sup> / <sub>4</sub> "
	Centre de table/Compotier 4et.	cm. 37 x 25	14 <sup>1</sup> / <sub>2</sub> " x 9 <sup>7</sup> / <sub>8</sub> "
	Tafelaufsatz/Obstschale 4-Stu.	Ø cm. 12	Ø 4 <sup>3</sup> / <sub>4</sub> "
Centro de mesa/Fruterio 4pisos	H cm. 49	H 19 <sup>1</sup> / <sub>3</sub> "	gal. 2
	lt. 7,2		

NEW

871



mm. 1,2	Cestino portafrutta	cm. 24 x 11	9 <sup>1</sup> / <sub>2</sub> " x 4 <sup>1</sup> / <sub>3</sub> "
	Fruit basket		
	Bol à fruits		
	Fruchtschale		
Cesto porta frutas			



565



mm. 1,2	Completo oliera con spargisale Cruet and salt cellar set Service huile-vinaigre Essig-/Ölgestell 4-tlg Convoy vinagreras con saleros	cm. 15x15 H cm. 12 cl. 18(x2) cl. 11(x2)	5 <sup>7</sup> / <sub>8</sub> " x 5 <sup>7</sup> / <sub>8</sub> " H 7 1 <sup>1</sup> / <sub>2</sub> " oz. 6 <sup>1</sup> / <sub>8</sub> (x2) oz. 3 <sup>3</sup> / <sub>4</sub> (x2)
---------	--	---	--

566



mm. 1,2	Formaggera Parmesan cheese basin Fromagère Käsedose Quesera-Azucarero	cl. 20	oz. 6 <sup>3</sup> / <sub>4</sub>
---------	---	--------	-----------------------------------

577

578



Coppetta tonda in vetro Individual bowl in glass Petit bol en verre Glasschale rund Tazon en vidrio	Ø cm. 12 H cm. 7,4 cl. 40  Ø 4 3 <sup>4</sup> / <sub>4</sub> " H 2 <sup>7</sup> / <sub>8</sub> " oz. 13 <sup>1</sup> / <sub>2</sub>	Insalatiera in vetro Salad bowl in glass Bol pour salade en verre Glassalatschale Ensaladera en vidrio	Ø cm. 21,5 H cm. 14 cl. 220  Ø 8 1 <sup>1</sup> / <sub>2</sub> " H 5 <sup>1</sup> / <sub>2</sub> " oz. 74 <sup>3</sup> / <sub>8</sub>
---	---	--	---

585

584



Coppetta quadra in vetro Glass square bowl Coupe carré en verre Glasschälchen quadratisch Cuenco cuadrado en vidrio	mm. 1,2	Coperchio per coppetta quadra Lid for square bowl Couvercle pour coupe carré Deckel für Schälchen quadratisch Tapa par cuenco cuadrado
cm. 10 x 10 - cl. 27 3 7 <sup>7</sup> / <sub>8</sub> " x 3 7 <sup>7</sup> / <sub>8</sub> " - oz. 9 <sup>1</sup> / <sub>8</sub>		cm. 10 x 10 3 7 <sup>7</sup> / <sub>8</sub> " x 3 7 <sup>7</sup> / <sub>8</sub> "

572



572A

Ampolla Cruet Huilliere Essig-/Ölflasche mit Spender Vinagrera	cl. 20 cl. 34 cl. 62	oz. 6 3 <sup>4</sup> / <sub>4</sub> oz. 11 1 <sup>1</sup> / <sub>2</sub> oz. 21	Bottiglia Glass bottle Bouteille Glasflasche mit Stopfen Botella
---	----------------------------	---	--

572



Le nostre ampolle sono il sistema più igienico di versare le arachidi perché si evita di mettere le mani nel contenitore  
Our glass bottles can be used to serve peanuts hygienically and without hand contact  
Notre bouteille en verre est le système le plus igiénique et pratique pour verser les arachides et éviter de mettre les mains dans le conteniteur  
Unsere formschöne Glaskaraffe eignet sich auch bestens als alternativer Spender für Erdnüsse. Eine Einladung für die Gäste, die die Erdnüsse nunmehr bequem dosieren können; somit wird ein direkter Kontakt mit den Fingern vermieden  
Nuestras jarras tienen el sistema más higiénico, de verter los cacahuetes, porque se evita meter las manos en el recipiente







# FINGER FOOD

557T



557

557T

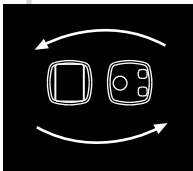

Combinabile con  
Ciotole in vetro  
Ciotole in policarbonato  
Ciotole in porcellana  
Coperchio in acciaio  
inossidabile 18/10

Combinable with  
Glass bowls  
Polycarbonate bowls  
China bowls  
18/10 st.st. lid

Combinable avec  
Bols en verre  
Bols en Polycarbonat  
Bols en porcelaine  
Couvercle en acier  
inoxydable18/10

Kombinierbar mit  
Glasschalen  
Polycarbonatschalen  
Porzellanschalen  
18/10-Deckel

Combinable con  
Cuencos en cristal  
Cuencos en policarbonato  
Cuencos en China  
Tapa en acero inoxidable  
18/10

561M



56138

561M

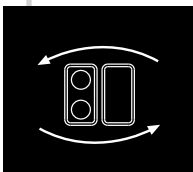

Combinabile con  
Ciotole in vetro  
Ciotole in policarbonato  
Vassoio in acciaio  
inossidabile 18/10

Combinable with  
Glass bowls  
Polycarbonate bowls  
Tray in 18/10  
stainless steel

Combinable avec  
Bols en verre  
Bols en Polycarbonat  
Plateau en acier  
inoxydable18/10

Kombinierbar mit  
Glasschalen  
Polycarbonatschalen  
Edelstahlschalen

Combinable con  
Cuencos en cristal  
Cuencos en policarbonato  
Cuencos en acero  
inoxidable 18/10

561T



561T

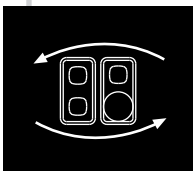

Combinabile con  
Ciotole in vetro  
Ciotole in policarbonato  
Ciotole in porcellana  
Coperchio in acciaio  
inossidabile 18/10  
Ampolle in vetro  
Piatti in vetro

Combinable with  
Glass bowls  
Polycarbonate bowls  
China bowls  
18/10 st.st. lid  
Glass bottles  
Glass trays

Combinable avec  
Bols en verre  
Bols en Polycarbonat  
Bols en porcelaine  
Couvercle en acier  
inoxydable18/10  
Bouteilles en verre  
Plateaus en verre

Kombinierbar mit  
Glasschalen  
Polycarbonatschalen  
Porzellanschalen  
18/10-Deckel  
Karaffen  
Glasplatten

Combinable con  
Cuencos en cristal  
Cuencos en policarbonato  
Cuencos en China  
Tapa en acero inoxidable  
18/10  
Botellas en vidrio  
Platos en vidrio



56122

561M

561T

# FINGER FOOD

563T15

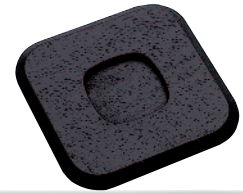

56315

563T15

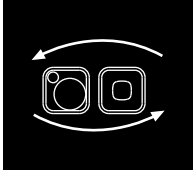

Combinabile con  
Ciotole in vetro  
Ciotole in policarbonato  
Ciotole in porcellana  
Coperchio in acciaio  
inossidabile 18/10  
Ampolle in vetro

Combinable with  
Glass bowls  
Polycarbonate bowls  
China bowls  
18/10 st.st. lid  
Glass bottles

Combinable avec  
Bols en verre  
Bols en Polycarbonat  
Bols en porcelaine  
Couvercle en acier  
inoxydable 18/10  
Bouteilles en verre

Kombinierbar mit  
Glasschalen  
Polycarbonatschalen  
Porzellanschalen  
18/10-Deckel  
Karaffen

Combinable con  
Cuencos en cristal  
Cuencos en policarbonato  
Cuencos en China  
Tapa en acero inoxidable  
18/10  
Botellas en vidrio

563T22



56322

563T22

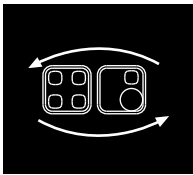

Combinabile con  
Ciotole in vetro  
Ciotole in policarbonato  
Ciotole in porcellana  
Coperchio in acciaio  
inossidabile 18/10  
Ampolle in vetro

Combinable with  
Glass bowls  
Polycarbonate bowls  
China bowls  
18/10 st.st. lid  
Glass bottles

Combinable avec  
Bols en verre  
Bols en Polycarbonat  
Bols en porcelaine  
Couvercle en acier  
inoxydable 18/10  
Bouteilles en verre

Kombinierbar mit  
Glasschalen  
Polycarbonatschalen  
Porzellanschalen  
18/10-Deckel  
Karaffen

Combinable con  
Cuencos en cristal  
Cuencos en policarbonato  
Cuencos en acero  
inoxidable 18/10  
Botellas en vidrio

563T22



567

563T22

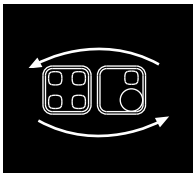

Combinabile con  
Ciotole in vetro  
Ciotole in policarbonato  
Ciotole in porcellana  
Coperchio in acciaio  
inossidabile 18/10  
Ampolle in vetro

Combinable with  
Glass bowls  
Polycarbonate bowls  
China bowls  
18/10 st.st. lid  
Glass bottles

Combinable avec  
Bols en verre  
Bols en Polycarbonat  
Bols en porcelaine  
Couvercle en acier  
inoxydable 18/10  
Bouteilles en verre

Kombinierbar mit  
Glasschalen  
Polycarbonatschalen  
Porzellanschalen  
18/10-Deckel  
Karaffen

Combinable con  
Cuencos en cristal  
Cuencos en policarbonato  
Cuencos en acero  
inoxidable 18/10  
Botellas en vidrio



578

577

584

587

585

572

572A

352



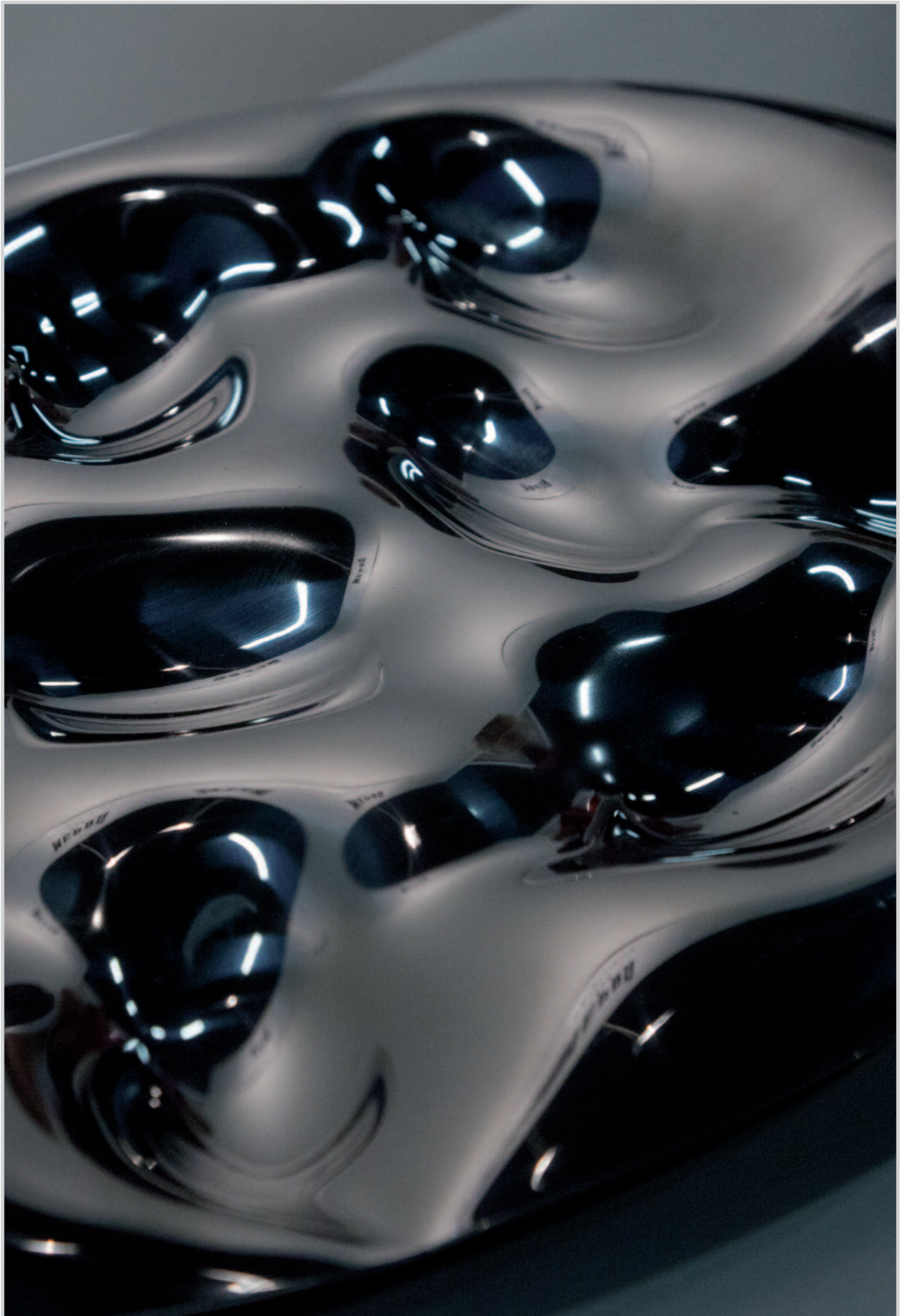

537

53706

53712



mm. 1,2	Mini vassoio quadro 6/12 comp. 6/12 comp. Mini square tray Mini plateau carré 6/12 pos. Mini Tablett, eckig., 6/12 Eins. Mini bandeja cuadrada 6/12 p.	cm. 12 x 12 cm. 15 x 15	4 3/4" x 4 3/4" 5 7/8" x 5 7/8"
---------	--	----------------------------	------------------------------------

549



mm. 1,2	Vassoio rettangolare 14 comp. Rectangular tray 14 comp. Plateau rectangulaire 14 plac. Tablett, rechteckig 14 Eins. Bandeja rectangular 14 posic.	cm 45 x 28	17 3/4" x 11 1/8"
---------	---	------------	-------------------

520

NEW

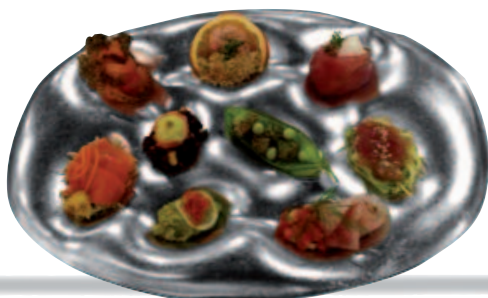

mm. 1,2	Vassoio ovale 9 compart. Oval tray 9 compartments Plateau oval 9 comp. Tablett, oval, 9 Einsätze Bandeja oval 9 posiciones	cm. 35 x 25,5	13 3/4" x 10"
---------	--	---------------	---------------

NEW

791E

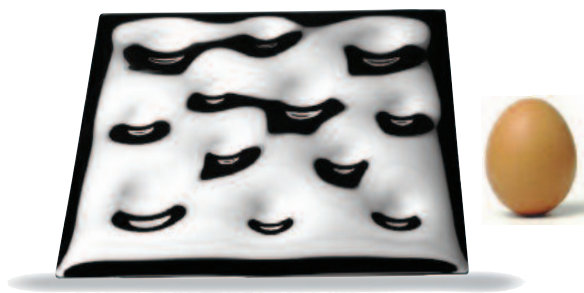

mm. 1,2	Vassoio da buffet per uova Egg tray for buffet Plateau à oeufs pour buffet Egg-tablett für Buffet Bandeja porta huevos por buffet	cm. 30 x 30	11 7/8" x 11 7/8"
---------	---	-------------	-------------------

52922



mm. 1,2	Vassoio quadro 8 compart. 8 comp. Square tray Plateau carré 8 pos. Tablett, eckig., 8 Eins. Bandeja cuadrada 8 posic.	cm. 22 x 22	8 5/8" x 8 5/8"
---------	---	-------------	-----------------

526

04

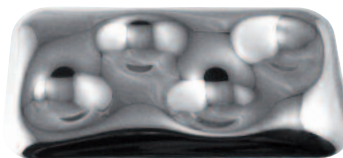

03



mm. 1,2	Vassoio rettangolare a 3 o 4 comp. Rectangular tray 3 or 4 comp. Plateau rectangulaire 3 ou 4 plac. Tablett, rechteckig 3 oder 4 Eins. Bandeja rectangular 3 o 4 posic.	cm. 23 x 13	9" x 5 1/8"
---------	---	-------------	-------------





10001129

NEW



mm. 2,5 | Quarta posata | Lungh. cm. 22,2 | Length 8 3/4"

530



mm. 1,2 | Mini vaporiera  
Mini steamer  
Mini vaporisateur  
Mini Verdampfer  
Mini vaporizador

Ø cm. 12	Ø 4 3/4"
H cm. 14,5	H 5 3/4"
cl. 24	oz. 8
Ø cm. 32	Ø 12 5/8"
H cm. 26	H 10 1/4"
lt. 3,0	oz. 101 2/5

NEW



282

mm. 1,2 | Braciere con pietre naturali  
Table grill with natural stones  
Brasier avec pierres naturelles  
Feuerschale mit Natursteine  
Hoguera c/piedras naturales

Ø cm. 15	Ø 5 7/8"
Ø cm. 22	Ø 8 5/8"
Ø cm. 32	Ø 12 5/8"

791AC



mm. 1,2 | Inserto per finger food  
Finger food insert  
Insért pour finger food  
Finger food Einsatz  
Inserto por finger food

cm. 30 x 30	117/8" x 117/8"
-------------	-----------------

See colors page 126

791



Vassoio/Sottopiatto  
Square Tray/Charger  
Plateau/Assiette de bienvenue  
Tablett/Platzteller,  
Bandeja/Bajo plato

cm. 32 x 32	12 3/4" x 12 3/4"
-------------	-------------------









252



mm. 1,2 | Centrotavola/Fruittiera  
Elevated centerpiece/Fruit-bowl  
Centre de table/Compotier  
Tafelaufsatz/Obstschale  
Centro de mesa/Fruterio

cm.38 x 25 | 15" x 9 7/8"  
H cm. 18 | H 7 1/8"  
cl. 300 | oz. 101 1/2

252G



mm. 1,2 | Alzata per pesce crudo  
Elevated rect.seafood presentation  
Serveur à poisson crude  
Etagere für marinierten Fisch  
Porta pescado

cm.38 x 25 | 15" x 9 7/8"  
H cm. 18 | H 7 1/8"  
cl. 300 | oz. 101 1/2

562/V



Rettangolare fondo con vassoio  
Rectangular cooling bowl for buffet with insert  
Bol rectangulaire à rafraichir avec insert  
Kühlschale, rechteckig mit Einsatzteile  
Bandeja refrescante rectangular con inserto

cm. 38 x 25 | 15" x 9 7/8"  
cl. 300 | oz. 101 1/2

562/G



Rettangolare fondo con griglia  
Elevated rect.seafood presentation with grill  
Bol rectangulaire à rafraichir avec grill  
Kühlschale, rechteckig mit Einsatzsieb  
Bandeja refrescante rectangular con rejilla

cm. 38 x 25 | 15" x 9 7/8"  
cl. 300 | oz. 101 1/2

56422N



Quadro fondo con vassoio  
Square cooling bowl for buffet with insert  
Bol carré à rafraichir avec insert  
Kühlschale, quadr. mit Einsatzteile  
Bandeja refrescante cuadrada con inserto

cm. 22x22 | 8 5/8" x 8 5/8"  
cl. 150 | oz. 50 3/4

56422/G



Quadro fondo con griglia  
Square individual seafood presentation with grill  
Bol carré à rafraichir avec grill  
Kühlschale, quadr. mit Einsatzsieb  
Bandeja refrescante cuadrada con rejilla

cm. 22x22 | 8 5/8" x 8 5/8"  
cl. 150 | oz. 50 3/4

262G



mm. 1,2	Alzata per pesce crudo	cm. 46 x 31	18 1/8" x 12 1/4"
	Elevated oval seafood presentation with grill	H cm. 18	H 7 1/8"
	Serviteur à poisson crude	cl. 400	gal. 1
	Etagere für marinierten Fisch		
	Porta pescado		

262



mm. 1,2	Centrotavola/Frutiera	cm. 46 x 31	18 1/8" x 12 1/4"
	Elevated centerpiece/Fruit-bowl	H cm. 18	H 7 1/8"
	Centre de table/Compotier	cl. 400	gal. 1
	Tafelaufsatz/Obstschale		
	Centro de mesa/Fruterio		

558/V



Ovale fondo con vassoio  
Oval cooling bowl for buffet with insert  
Bol oval à rafraichir avec insert  
Kühlschale, oval mit Einsatzteile  
Bandeja refrescante oval con inserto

cm. 46 x 31	18 1/8" x 12 1/4"
cl. 400	gal. 1

558/G



Ovale fondo con griglia  
Oval seafood presentation with grill  
Bol oval à rafraichir avec grill  
Kühlschale, oval mit Einsatzsieb  
Bandeja refrescante oval con rejilla

cm. 46 x 31	18 1/8" x 12 1/4"
cl. 400	gal. 1

56022/G



Tondo fondo con griglia  
Round individual seafood presentation with grill  
Bol ronde à rafraichir avec grill  
Kühlschale, rund mit Einsatzsieb  
Bandeja refrescante redonda con rejilla

Ø cm. 22	Ø cm. 8 5/8"
cl. 150	oz. 50 3/4

56022/V



Tondo fondo con vassoio  
Round cooling bowl for buffet with insert  
Bol ronde à rafraichir avec insert  
Kühlschale, rund mit Einsatzteile  
Bandeja refrescante redonda con inserto

Ø cm. 22	Ø cm. 8 5/8"
cl. 150	oz. 50 3/4



242G



mm. 1,2	Alzata tonda per pesce crudo	Ø cm.32	Ø 12 5/8"
	Elevated round thirty-two stand	H cm. 19	H 7 1/2"
	Serviteur ronde à poisson crude	lt. 3,0	oz. 101 2/5
	Etagere, rund, für marinierte Fisch		
	Porta pescado redondo		

26202G



mm. 1,2	Alzata ovale per pesce crudo 2p	cm. 46 x 31	18 1/8" x 12 1/4"
	Oval two tier seafood stand	cm. 37 x 25	14 1/2" x 9 7/8"
	Serviteur ovale à poisson crude	H cm. 28	H 11 1/8"
	Etagere, oval, für marinierten Fisch	lt. 6,5	gal. 1 5/7
	Porta pescado oval 2 pisos		

24202G



mm. 1,2	Alzata tonda per pesce crudo 2p	Ø cm. 32	Ø 12 5/8"
	Round two tier seafood stand	Ø cm. 22	Ø 8 5/8"
	Servit.ronde à poisson crude 2 et.	H cm. 29,5	H 11 3/5"
	Etagere, rund, für marinierte Fisch 2-Stufig	lt. 4,3	gal. 1 1/8
	Porta pescado redondo 2 pisos		

26203G



mm. 1,2	Alzata ovale per pesce crudo 3p	cm. 46 x 31	18 1/8" x 12 1/4"
	Oval three tier seafood stand	cm. 37 x 25	14 1/2" x 9 7/8"
	Serviteur ovale à poisson crude	Ø cm. 12	Ø 4 3/4"
	Etagere, oval, für marinierten Fisch 3 -Stufig	H cm. 37	H 14 1/2"
	Porta pescado oval 3 pisos	lt. 6,7	gal. 1 3/4

485

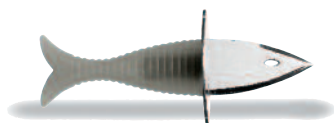

APRIL	cm. 15	5 7/8"
Coltello per ostriche		
Oyster knife		
Couteau à huîtres		
Austernöffner		
Cuchillo de ostras		

26204G



mm. 1,2	Alzata ovale per pesce crudo 4p	cm. 55 x 24	21 5/8" x 9 1/2"
	Oval four tier seafood stand	cm. 46 x 31	18 1/8" x 12 1/4"
	Serviteur ovale à poisson crude	cm. 37 x 25	14 1/2" x 9 7/8"
	Etagere, oval, für marinierten Fisch 4-Stufig	Ø cm. 12	Ø 4 3/4"
	Porta pescado oval 4 pisos	H cm. 49	H 19 1/3"
		lt. 7,2	gal. 2

235G



mm. 1,2 | Vassoio rotondo per pesce crudo | Ø cm.38 | Ø 15"  
 Round seafood tray | H cm. 9 | H 3 1/2"  
 Plateau rond à poisson crude | lt. 3,0 | oz. 101 2/5  
 Tablett, rund für marinierten Fisch  
 Porta pescado redondo

235



mm. 1,2 | Centrotavola/Fruittiera | Ø cm.38 | Ø 15"  
 Centerpiece/Fruit-bowl | H cm. 9 | H 3 1/2"  
 Centre de table/Compotier | lt. 3,0 | oz. 101 2/5  
 Tafelaufsatz/Obstschale  
 Centro de mesa/Fruterio







804



TRE  
Portacondimenti  
Basket for aromatic condiments  
Corbeille pour aromatiques condiments  
Tisch-Essig/Öl-Flaschenhalter  
Cesto para aromaticos y condimentos

cm. 15 x 15 | 6" x 6"  
H cm. 19,6 | H 7 3/4"

799



TRE  
Ciotola quadra  
Square bowl  
Bol, carré  
Universalschale auf Holz, quadratisch  
Cuenco cuadrado

cm. 6 x 6 | 2 3/8" x 2 3/8"

599

58928

12 colori disponibili - pag. 253  
12 colors available - page 253  
12 couleurs disponibles - pag. 253  
12 verschiedenen Farben verfügbar - Seite 253  
12 colores disponibles - pag. 253

589 - Ø cm. 28  
Ø 11"



mm. 1,2 | UNO  
Cestino traforato  
Fretworked basket  
Corbeille, ajourée  
Früchtekorb gelocht  
Cesta perforada

Ø cm. 29 | Ø 11 3/8"  
H cm. 18,5 | H 7 1/4"  
lt. 8 | gal. 2

666B



TRE  
Colonna portasecchiello  
Wine cooler stand  
Pied pour seau à champagne  
Weinkühlerständer  
Columna porta cubo champany

H cm. 65 | H 25 5/8"



792



TRE  
Vassoio rettangolare  
Rectangular tray  
Plateau rectangulaire  
Tablett, rechteckig  
Bandeja rectangular

cm. 50 x 32	19 3/4" X 12 3/4"
cm. 30 x 20	11 3/4" X 7 7/8"

788

NEW



QUATTRO  
Vassoio rettangolare  
Rectangular tray  
Plateau rectangulaire  
Tablett, rechteckig  
Bandeja rectangular

cm. 50 x 32	19 3/4" X 12 3/4"
cm. 30 x 20	11 3/4" X 7 7/8"

791



TRE  
Vassoio/Sottopiatto  
Square Tray/Charger  
Plateau/Assiette de bienvenue  
Tablett/Platzteller,  
Bandeja/Bajo plato

cm. 32 x 32	12 3/4" x 12 3/4"
-------------	-------------------

789

NEW



QUATTRO  
Vassoio/Sottopiatto  
Square Tray/Charger  
Plateau/Assiette de bienvenue  
Tablett/Platzteller,  
Bandeja/Bajo plato

cm. 32 x 32	12 3/4" x 12 3/4"
-------------	-------------------

795



TRE  
Tovaglietta americana  
Place mat  
Set de table  
americain en bois  
Tischset aus Holz  
individual en madera

cm. 38 x 28	15" x 11"
-------------	-----------

796



TRE  
Sottopiatto  
Charger  
Assiette de bienvenue  
Platzteller  
Bajo plato

Ø cm. 33	Ø 13"
----------	-------

787

787

NEW



TRE  
Vassoio per prima colazione  
Breakfast tray  
Plateau rect. pour le petit déjeuner  
Frühstück Tablett, rechteckig  
Bandeja rect. por desayuno

cm. 30 x 20 | 11 3/4" X 7 7/8"

791AC



Inserto Finger Food per vassoio quadro e rettangolare  
Finger Food insert for square and rectangular tray  
Insért Finger Food pour plateau carré et rectangulaire  
Finger Food-Einsatz für quadratische/rechteckig Schale  
Inserto para Finger Food por bandeja cuadrada y rectangular

cm. 30 x 30 | 11 7/8" x 11 7/8"

793

794



TRE  
Completo oliera con spargisale  
Cruet and salt cellar set  
Huile-vinaigre 4 pcs  
Essig-/Öl-Menage 4-Tlg.  
Vinagreras con saleros

cm. 15 x 15 | 6" x 6"  
H cm. 19,6 | H 7 3/4"  
cl. 30 (x2) | oz. 10 1/8 (x2)  
cl. 8 (x2) | oz. 2 3/4 (x2)



TRE  
Formaggera  
Parmesan cheese basin  
Fromagère  
Käsedose  
Quesera Azucarero

cm. 15 x 15 | 6" x 6"  
cl. 20 | oz. 6 3/4





**W** Bianco  
White  
Blanc  
Weiss  
Blanco



**N** Nero  
Black  
Noir  
Schwarz  
Negro



**V7** Viola  
Violet  
Violet  
Pflaume  
Violeta



**O** Arancio  
Orange  
Orange  
Orange  
Naranja



**L7** Lime  
Lime  
Lime  
Limone  
Lima



**A** Noce  
Walnut  
Noyer  
Walnuss  
Nuez

**N E W**



**N E W**

**R** Rovere  
Oak  
Chêne  
Eiche  
Roble

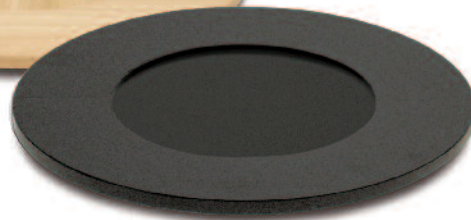

**W** Wengé





792



TRE  
Vassoio rettangolare  
Rectangular tray  
Plateau rectangulaire  
Tablett, rechteckig  
Bandeja rectangular

cm. 50 x 32	19 3/4" X 12 3/4"
cm. 30 x 20	11 3/4" X 7 7/8"

NEW

788



QUATTRO  
Vassoio rettangolare  
Rectangular tray  
Plateau rectangulaire  
Tablett, rechteckig  
Bandeja rectangular

cm. 50 x 32	19 3/4" X 12 3/4"
cm. 30 x 20	11 3/4" X 7 7/8"

791



TRE  
Vassoio/Sottopiatto  
Square Tray/Charger  
Plateau/Assiette de bienvenue  
Tablett/Platzteller,  
Bandeja/Bajo plato

cm. 32 x 32	12 3/4" x 12 3/4"
-------------	-------------------

NEW

789



QUATTRO  
Vassoio/Sottopiatto  
Square Tray/Charger  
Plateau/Assiette de bienvenue  
Tablett/Platzteller,  
Bandeja/Bajo plato

cm. 32 x 32	12 3/4" x 12 3/4"
-------------	-------------------

795



TRE  
Tovaglietta americana  
Place mat  
Set de table  
americain en bois  
Tischset aus Holz  
individual en madera

cm. 38 x 28	15" x 11"
-------------	-----------

796



TRE  
Sottopiatto  
Charger  
Assiette de bienvenue  
Platzteller  
Bajo plato

Ø cm. 33	Ø 13"
----------	-------

787



NEW

787

TRE  
Vassoio per prima colazione  
Breakfast tray  
Plateau rect. pour le petit déjeuner  
Frühstück Tablett, rechteckig  
Bandeja rect. por desayuno

cm. 30 x 20 | 11 3/4" X 7 7/8"

791AC



Inserto Finger Food per vassoio quadro e rettangolare  
Finger Food insert for square and rectangular tray  
Insért Finger Food pour plateau carré et rectangulaire  
Finger Food-Einsatz für quadratische/rechteckig Schale  
Inserto para Finger Food por bandeja cuadrada y rectangular

cm. 30 x 30 | 11 7/8" x 11 7/8"

802

801



TRE  
Portagioie/Portapasticcini  
Jewel case/Petit fours case  
Porte bijoux/Porte petit patisserie  
Schmuckablage/Bonbonträger  
Joyero/Porta dulces

cm. 15 x 15 | 6" x 6"

794



Formaggera  
Parmesan cheese basin  
Fromagère  
Käsedose  
Quesera Azucarero

cm. 15 x 15  
cl. 20  
6" x 6"  
oz. 6 3/4

793



Completo oliera con spargisale  
Cruet and salt cellar set  
Huile-vinaigre 4 pcs  
Essig-/Öl-Menage 4-Tlg.  
Vinagreras con saleros

cm. 15 x 15  
H cm. 19,6  
cl. 30 (x2)  
cl. 8 (x2)  
6" x 6"  
H 7 3/4"  
oz. 10 1/8 (x2)  
oz. 2 3/4 (x2)

804



Portacondimenti  
Basket for aromatic condiments  
Corbeille pour aromatiques condiments  
Tisch-Essig/Öl-Flaschenhalter  
Cesto para aromaticos y condimentos

cm. 15 x 15  
H cm. 19,6  
6" x 6"  
H 7 3/4"





3504

3404

S7



S7



BARCELONA

J



J



Ø cm. 12,5

Ø 5"

cm. 14 x 14

5 1/2" x 5 1/2"

3503

3403

F7



F7



AMSTERDAM

N7



N7



Ø cm. 12,5

Ø 5"

cm. 14 x 14

5 1/2" x 5 1/2"

3505

3405

H7



H7



BERLIN

Q7



Q7

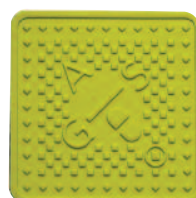

Ø cm. 12,5

Ø 5"

cm. 14 x 14

5 1/2" x 5 1/2"







# STREET COVER

3200

S7



S7



S7



3300

J

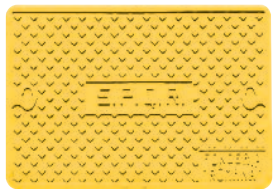

J



J



cm. 30 x 45

11 3/4" x 17 3/4"

Ø cm. 17  
Ø cm. 35

Ø 6 3/4"  
Ø 13 7/8"

cm. 45 x 45

17 3/4" x 17 3/4"

3202

F7



F7



F7



3302

N7



N7



N7



cm. 30 x 45

11 3/4" x 17 3/4"

Ø cm. 17  
Ø cm. 35

Ø 6 3/4"  
Ø 13 7/8"

cm. 45 x 45

17 3/4" x 17 3/4"

3201

H7



H7



H7



3301

Q7



Q7



Q7



cm. 30 x 45

11 3/4" x 17 3/4"

Ø cm. 17  
Ø cm. 35

Ø 6 3/4"  
Ø 13 7/8"

cm. 45 x 45

17 3/4" x 17 3/4"





845



84501



84504



843

856



mm. 1,2 | Portaghiaccio termico con coperchio  
Insulated ice-bucket with lid  
Seau à glaçons thermique  
avec couvercle  
Isolier-Eisgefäß, mit Deckel  
Cubitera hielo con tapa

Ø cm 14	Ø 5 1/2"
H cm 13	H 5"
cl. 72	oz. 24 1/3
Ø cm 24	Ø 9 1/2"
H cm 22	H 8 5/8"
lt. 4,0	gal. 1

mm. 1,2 | Secchiello per spumante  
Sparkling wine cooler  
Seau à champagne  
Wein- und Sektkühler  
Cubo para champany

Ø cm 24	Ø 9 1/2"
H cm 22	H 8 5/8"
lt. 4,0	gal. 1
Ø cm 14	Ø 5 1/2"
H cm 13	H 5"
cl. 125	oz. 42 1/4

666G

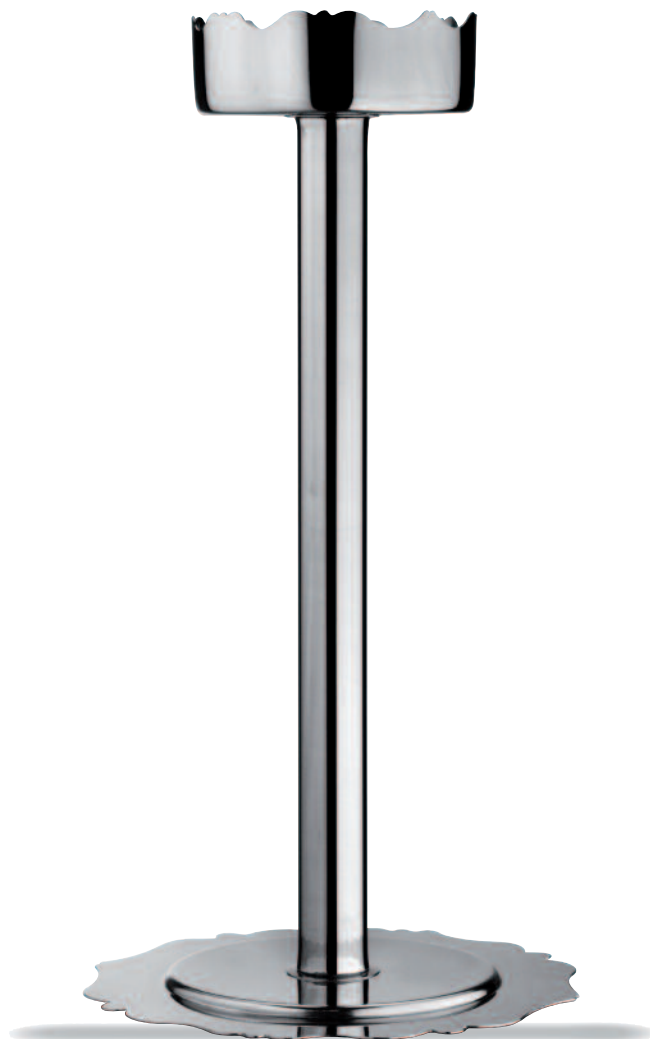

mm. 1,2 | Colonna portasecchiello spumante  
Wine cooler stand  
Pied pour seau à champagne  
Weinkühlerständer  
Columna porta cubo champany

H cm. 62	H 24 3/8"
----------	-----------



800



mm. 1,2	Vassoio rettangolare c/interno ovale Rectangular tray, w/oval int.part Plateau rectangulaire a/partie interne ovale Tablett rechteckig mit ovaler Innenform Bandeja rectangular con la parte interna ovalada	cm. 47x34 cm. 56x40	18 <sup>1</sup> / <sub>2</sub> " x 13 <sup>3</sup> / <sub>8</sub> " 22" x 15 <sup>3</sup> / <sub>4</sub> "
---------	--	------------------------	---

808



mm. 1,2	Vassoio quadro con interno tondo Square tray, w/round internal part Plateau carré a/partie interne ronde Tablett quadratisch mit runder Innenform Bandeja cuadrada c/la parte interna redonda	cm. 40x40	15 <sup>3</sup> / <sub>4</sub> " x 15 <sup>3</sup> / <sub>4</sub> "
---------	---	-----------	---

801



mm. 1,2	Vassoio rettangolare c/int.ovale c/piedini Rect.tray, w/oval int.part and feet Plateau rect.a/partie ovale int. sur pied Tablett rechteckig mit ovaler Innenform und Füßen Bandeja rect.c/parte int.oval.y pies	cm. 47x34 cm. 56x40	18 <sup>1</sup> / <sub>2</sub> " x 13 <sup>3</sup> / <sub>8</sub> " 22" x 15 <sup>3</sup> / <sub>4</sub> "
---------	---	------------------------	---

809



mm. 1,2	Vassoio quadro c/int.tondo c/piedini Square tray, w/round int.part w/feet Plat.carré a/partie int.ronde s/pied. Tablett quadratisch mit runder Innenform und Füßen Band.cuad.c/parte int.red.y 3 pies	cm. 40x40	15 <sup>3</sup> / <sub>4</sub> " x 15 <sup>3</sup> / <sub>4</sub> "
---------	---	-----------	---

802



mm. 1,2	Vassoio rett.c/int.ovale e pied. Rect.tray, w/oval int.part w/base Plateau rect.a/par.int. ovale s/socle Tablett rechteckig mit ovaler Innenform und Fuss Bandeja rect.c/parte int.oval. y pedestal	cm. 47x34 cm. 56x40 H cm. 14	18 <sup>1</sup> / <sub>2</sub> " x 13 <sup>3</sup> / <sub>8</sub> " 22" x 15 <sup>3</sup> / <sub>4</sub> " H 5 1/2"
---------	---	------------------------------------	---

807



mm. 1,2	Vassoio quadro c/int.tondo c/pied. Square tray, w/round int.part w/base Plat.carré a/partie int.ronde e/socle Petits Fours-Ständer Band.cuad.c/parte int.red.y pedest.	cm. 40x40 H cm. 18	15 3/4" x 15 3/4" H 7"
---------	--	-----------------------	---------------------------

805



mm. 1,2	Vassoio rettangolare Rectangular Tray Plateau rectangulaire Tablett rechteckig Bandeja rectangular	cm. 48 x 36	18 <sup>7</sup> / <sub>8</sub> " x 14 <sup>1</sup> / <sub>8</sub> "
---------	--	-------------	---

861



mm. 1,2	Vassoio portalettere/portaconto Tray for correspondence, for bill Plateau à main Tablett für Korrespondenz oder Rechnungen Bandeja para la correspondencia o facturas	cm. 26 x 22	10" x 8 <sup>1</sup> / <sub>2</sub> "
---------	---	-------------	---------------------------------------

806



mm. 1,2	Vassoio rett.c/int.rett.con piedini Rect.tray, w/rect.int.part and feet Plateau rect.a/partie int.rect.s/pied Tablett rechteckig mit Füßen Bandeja rect.c/parte int.rect.c/4 pies	cm. 26x22 cm. 48x36	10" x 8 <sup>1</sup> / <sub>2</sub> " 18 <sup>7</sup> / <sub>8</sub> " x 14 <sup>1</sup> / <sub>8</sub> "
---------	---	------------------------	--

862



mm. 1,2	Vassoio portalettere, portaconto con piedini Tray for correspondence, for bill w/feet Plateau à main sur pieds Tablett für Korrespondenz oder Rechnungen mit Füßen Bandeja para la correspondencia o facturas con 4 pies	cm. 26 x 22	10" x 8 <sup>1</sup> / <sub>2</sub> "
---------	---	-------------	---------------------------------------

810



mm. 1,2	Vassoio rett.c/int.rett.con piedist. Rect.tray, w/rect.int.part and base Plateau rect.a/partie int.rect.s/socle Tablett rechteckig mit Fuss Bandeja rect.c/parte int.rect.c/ped.	cm. 26x22 cm. 48x36 H cm. 14	10 x 8 <sup>1</sup> / <sub>2</sub> " 18 <sup>7</sup> / <sub>8</sub> " x 14 <sup>1</sup> / <sub>4</sub> " H 5 <sup>1</sup> / <sub>2</sub> "
---------	--	------------------------------------	--

863



mm. 1,2	Vassoio portalettere, portaconto con piedistallo Tray for correspondence, for bill w/feet Plateau pour la correspondance ou factures sur socle Tablett für Korrespondenz od.Rechnungen m/Fuss Bandeja para la correspondencia o facturas c/ped.	26 x 22 H 13,5	10" x 8 <sup>1</sup> / <sub>2</sub> " H 5 <sup>3</sup> / <sub>8</sub> "
---------	--	-------------------	--



860



mm. 1,2	Cestino rotondo	Ø cm. 18 cl. 110	Ø 7 1/8" oz. 37 1/5
	Round bowl Bol rond/Corbeille Obstschale, rund Cuenco redondo		

858



mm. 1,2	Ciotola finger food/amouse/bouche/burro	Ø cm. 8,5 cl. 28	Ø 3 3/8" oz 9 1/2
	Finger food/amouse bouche/butter bowl Bol multi-usages Fingerfood-/Vorspeisen-/Butter-Gefäß Cuenco para finger food/amouse bouche/mantequilla		

826



mm. 1,2	Cestino	cm. 13 x 13	5 1/8" x 5 1/8"
	Basket	cm. 16 x 16	6 3/8" x 6 3/8"
	Corbeille	cm. 32 x 32	12 5/8" x 12 5/8"
	Obstschale Cuenco		

828



mm. 1,2	Centrotavola	cm. 27 x 27	10 5/8" x 10 5/8"
	Centerpiece	H cm. 7	H 2 7/8"
	Centre de table	lt. 2,4	oz. 94 2/3
	Tafelaufsatz	cm. 37 x 37	14 5/8" x 14 5/8"
	Centro de mesa	H cm. 7 lt. 4	H 2 7/8" gal. 1

827



mm. 1,2	Cestino con piedistallo	cm. 13 x 13	5 1/8" x 5 1/8"
	Basket with base	H cm. 19,5	H 7 5/8"
	Corbeille sur socle	cl. 85	oz. 28 3/4
	Obstschale auf Fuss	cm. 16 x 16	6 3/8" x 6 3/8"
	Cesta con pedestal	H cm. 23 cl. 172	H 9" oz. 58 1/7
		cm. 32 x 32 H cm. 26,5 lt. 4,82	12 5/8" x 12 5/8" H 10 1/2" gal. 1 1/4

841



mm. 1,2	Piatto da torta con piedistallo	Ø cm. 30	Ø 11 7/8"
	Cakes plate with base	Ø cm. 40	Ø 15 3/4"
	Plat à tarte sur socle	H cm. 16.5	H 6 1/2"
	Kuchenplatte auf Fuß Bandeja tarta con pedestal		

840



mm. 1,2	Portabustine/biglietti da visita Sugar packet/business card holder Porte cartes/sachets Zuckerstangengefäß-Kartenhalter Azucarera/Porta tarjetas comerciales	cm. 10 x 7	4 1/8" x 2 7/8"
---------	--	------------	-----------------

830



mm. 1,2	Svuotatasche Square basket Corbeille carré Brotkorb, quadratisch Cuenco cuadrado	cm. 15 x 15 cm. 22 x 22	5 7/8" x 5 7/8" 8 5/8" x 8 5/8"
---------	--	----------------------------	------------------------------------

848



mm. 1,2	Porta pasticcini Petit-fours stand Porte-petits fours Petits Fours-Ständer Porta dulces	Ø cm. 14 H cm. 9,5	Ø 5 1/2" H 3 3/4"
		Ø cm. 21 H cm. 14	Ø 8 1/4" H 5 1/2"

847



842



mm. 1,2	Porta pasticcini a 2 piani Petit-fours stand 2 layers Porte-petit fours 2 étages Mokkaétagerè 2 Ebenen Porta dulces 2 pisos	Ø cm. 14 Ø cm. 21 H cm 25,5	Ø 5 1/8" Ø 8 1/4" H 10"
---------	---	-----------------------------------	-------------------------------

mm. 1,2	Alzata portafrutta rettangolare 2p. Rectangular fruit holder 2 layers Serveur rectangulaire 2 étages Etagere, rechteckig 2-stufig Frutero rectangular 2 pisos	cm. 47 x 34 cm. 56 x 40 H cm. 44	18 1/2" x 13 3/8" 22" x 15 3/4" H 17 3/8"
---------	---	--	---



813



mm. 1,2	Sottopiatto quadro Square charger Assiette de bienvenue carrée Platzteller, viereckig Bajo plato cuadrado	cm. 32 x 32	12 5/8" x 12 5/8"
---------	---	-------------	-------------------

814



mm. 1,2	Sottopiatto Charger Assiette de bienvenue Platzteller Bajo plato	Ø cm. 32	Ø 12 5/8"
---------	--	----------	-----------

838



mm. 1,2	Sottobicchiere Glass coaster Dessous de verre Glasuntersatz Posavasos	cm. 10 x 10	4" x 4"
---------	---	-------------	---------

839



mm. 1,2	Sottobottiglia Bottle coaster Dessous de bouteille Flaschenteller Posabotella	cm. 14 x 14	5 1/2" x 5 1/2"
---------	---	-------------	-----------------

833

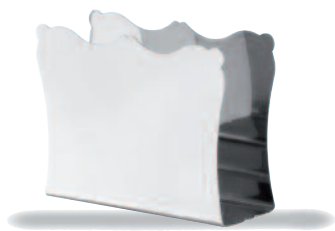

mm. 1,0	Portatovaglioli Napkin holder Distributeur de serviettes Serviettenhalter Portaservilletas	cm. 12,5 x 4 H cm. 9	5" x 1 5/8" H 3 1/2"
---------	--	-------------------------	-------------------------

846



mm. 1,0	Vasetto portafiori Flower vase Soliflore Blumenvase Florero	H cm. 14	H 5 1/2"
---------	---	----------	----------

81601



mm. 3,0	Allacciatovaglioli Napkins ring Rond de serviettes Serviettenring Servilletero	Ø cm 9	Ø 3 1/2"
---------	--	--------	----------

81602



mm. 3,0	Allacciatovaglioli Napkins ring Rond de serviettes Serviettenring Servilletero	Ø cm 9	Ø 3 1/2"
---------	--	--------	----------

81603



mm. 3,0	Allacciatovaglioli Napkins ring Rond de serviettes Serviettenring Servilletero	cm 9 x 8	3 1/2" x 3 1/7"
---------	--	----------	-----------------

81604



mm. 3,0	Allacciatovaglioli Napkins ring Rond de serviettes Serviettenring Servilletero	cm. 8 x 8	3 1/7" x 3 1/7"
---------	--	-----------	-----------------

81605



mm. 3,0	Allacciatovaglioli Napkins ring Rond de serviettes Serviettenring Servilletero	cm. 8 x 8	3 1/7" x 3 1/7"
---------	--	-----------	-----------------

81606



mm. 3,0	Allacciatovaglioli Napkins ring Rond de serviettes Serviettenring Servilletero	cm. 10 x 7	4" x 2 5/8"
---------	--	------------	-------------



812



mm. 1,2	Formaggera Parmesan cheese basin Fromagère Käsedose Quesera Azucarero	Ø cm. 14 cl. 20	Ø 5 1/2" oz. 6 3/4
---------	---	--------------------	-----------------------

811



mm. 1,2	Completo oliera con spargisale Cruet and salt cellar set Service huile-vinaigre 4pcs. Essig-/Ölgestell 4-Tlg. Convoy vinagreras con saleros 4 pzas.	Ø cm. 21 H cm. 19,6 cl. 76	Ø 8 1/4" H 7 3/4" oz. 25 3/4
---------	--	----------------------------------	------------------------------------

825



mm. 1,2	Lasagnera rettangolare Set for Lasagne Service à lasagnes Set mit Porzellanschale, rechteckig Servicio para Lasagne	cm. 48 x 36 lt. 3	18 7/8" x 14 1/8" oz. 102 4/5
---------	--	----------------------	----------------------------------

817



mm. 1,2	Antipastiera Hors d'oeuvre tray Plat à hors-d'oeuvre Vorspeisenplatte Entremesera	cm. 40 x 40	15 3/4" x 15 3/4"
---------	---	-------------	-------------------

854



mm. 1,2	Portachiavi Key holder Porte-clés Schlüsselanhänger Portallaves	cm. 8 x 8	3 1/8" x 3 1/8"
---------	---	-----------	-----------------

837



mm. 1,2	Portaspezie Aromatic condiments set Service pour aromatiques condiments Gewürzständer Servicio para aromaticos y condimentos	cm. 15 x 15 H cm. 25,5 cl. 11 (x 8)	5 7/8" x 5 7/8" H 10" oz. 3 3/4 (x 8)
---------	--	---	---

851



mm. 1,2	Alzata per pesce crudo Elevated rect.seafood presentation Serveur à rafraîchir le poisson Etagerer für marinierte Fisch Porta pescado	cm. 56 x 40 H cm. 18 lt. 4,0	22" x 15 3/4" H 7 1/8" gal. 1
---------	---	------------------------------------	-------------------------------------

852



mm. 1,2	Vassoio rotondo Round tray Plateau rond Tablett rund Bandeja redonda	Ø cm. 21	Ø 8 1/4"
---------	--	----------	----------

819



mm. 1,2	Antipastiera 5 scomparti in porcellana China hors-d'oeuvre tray 5 compt. Service à Hors d'oeuvres Set Vorspeisenplatte aus Porzellan 5 Eins. Entremesera en porcelana 5 comp.	cm. 40 x 40	15 3/4" x 15 3/4"
---------	---	-------------	-------------------

820



mm. 1,2	Risottiera Set for risotti Service à Risotto Set mit Porzellanschale, rund Servicio para arroces	cm. 40 x 40 cl. 200	15 3/4" x 15 3/4" oz. 67 3/5
---------	--	------------------------	---------------------------------

836



mm. 1,2	Portabicchieri di carta Paper cup holder Porte-gobelets de papier Papierbecherständer Portavasos de papel	cm. 23 x 12,5 H cm. 22,5	8 7/8" x 4 7/8" H 8 7/8"
---------	---	-----------------------------	-----------------------------

831



mm. 1,2	Portacondimenti con astina Basket for aromatic condiments Support pour Condiments et Aromates Essig-/Ölflaschenhalter Cestos para aromaticos y condimentos	cm. 15 x 15 H cm. 33	5 7/8" x 5 7/8" H 13"
---------	--	-------------------------	--------------------------



853

853



mm. 3,0

Segnaposto  
Table number stand  
Numéro de table  
Tischnummern-Ständer  
Numero de mesa

Ø cm. 9  
H cm. 9

Ø 3 1/2"  
H 3 1/2"

cm. 10 x 7  
H cm. 7

4 x 2 3/4"  
H 2 3/4"

cm. 8 x 8  
H cm. 8

3 1/8" x 3 1/8"  
H 3 1/8"

7061

7064



7061

7062

7063

7064

Candelabro bugia  
Candlestick  
Chandelier  
Leuchter  
Candelabro

H cm. 13  
H 5 1/8"

Candelabro a 1 fiamma  
Candlestick  
Chandelier  
Leuchter 1 Flam.  
Candelabro

H cm. 23,6  
H 9 1/4"

Candelabro a 3 fiamme  
Candelabra, 3 arms  
Chandelier 3 flammes  
Leuchter 3 Flammig  
Candelabro 3 luces

H cm. 23,6  
H 9 1/4"

Candelabro a 5 fiamme  
Candelabra, 5 arms  
Chandelier 5 flammes  
Leuchter 5 Flammig  
Candelabro 5 luces

H cm. 23,6  
H 9 1/4"

866

NEW



mm. 3,0

Segnaposto  
Table number stand  
Numéro de table  
Tischnummern-Ständer  
Numero de mesa

Ø cm. 3,5

Ø 1 1/3"

411



mm. 1,2  
Caffetteria  
Coffee pot  
Cafetière  
Kaffeekanne  
Cafetera

Tazze	2	cl. 25	8 1/2 oz.
Cups	4	cl. 37	12 1/2 oz.
Bols	6	cl. 52	17 5/8 oz.
Tassen	8	cl. 70	23 5/8 oz.
Tazas	10	cl. 100	33 7/8 oz.
	12	cl. 150	50 3/4 oz.
	16	cl. 200	67 5/8 oz.

412



mm. 1,2  
Teiera  
Tea pot  
Théière  
Teekanne  
Tetera

Tazze	4	cl. 55	18 5/8 oz.
Cups	6	cl. 70	23 5/8 oz.
Bols	8	cl. 97	32 3/4 oz.
Tassen			
Tazas			

413



mm. 1,2  
Lattiera  
Milk jug  
Pot à lait  
Milchkanne  
Jarra lechera

Tazze	1	cl. 10	3 3/8 oz.
Cups	2	cl. 25	8 1/2 oz.
Bols	4	cl. 37	12 1/2 oz.
Tassen	6	cl. 52	17 5/8 oz.
Tazas	8	cl. 70	23 5/8 oz.
	10	cl. 100	33 7/8 oz.
	12	cl. 150	50 3/4 oz.
	16	cl. 200	67 5/8 oz.

414



mm. 1,2  
Zuccheriera  
Sugar bowl  
Sucrier  
Zuckerdose  
Azucarero

Tazze	4	cl. 18	6 1/8 oz.
Cups	8	cl. 30	10 1/8 oz.
Bols			
Tassen			
Tazas			





305

315



mm. 1,2	Vassoio rettangolare	cm. 40,5 x 27,5	15 <sup>7</sup> / <sub>8</sub> " x 10 <sup>3</sup> / <sub>4</sub> "
	Rectangular tray	cm. 45 x 31	17 <sup>3</sup> / <sub>4</sub> " x 12 <sup>1</sup> / <sub>4</sub> "
	Plateau rectangulaire		
	Tablett, rechteckig		
	Bandeja rectangular		



mm. 1,2	Sottobicchiere e sottobottiglia	cm. 10 x 10	4" x 4"
	Glass and bottle coaster	cm. 12,5 x 12,5	5" x 5"
	Dessous de verre et de bouteille		
	Glasuntersatz - Flaschenteller		
	Posavasos y Posabotella		

323

313



mm. 1,2	Sottopiatto quadrato	cm. 32 x 32	12 <sup>1</sup> / <sub>2</sub> " x 12 <sup>1</sup> / <sub>2</sub> "
	Square charger		
	Assiette de bienvenue carré		
	Platzteller, viereckig		
	Bajo plato cuadrado		



mm. 0,8	Sottopiatto	Ø cm. 31	Ø 12 1/4"
	Charger		
	Assiette de bienvenue		
	Platzteller		
	Bajo plato		

319

320



mm. 1,2	Vassoio quadrato	cm. 32 x 32	12 <sup>1</sup> / <sub>2</sub> " x 12 <sup>1</sup> / <sub>2</sub> "
	Square plate		
	Plateau carré		
	Tablett, viereckig		
	Bandeja cuadrada		



mm. 1,2	Vassoio "Tête à tête"	Ø cm. 22	Ø 8 5/8"
	"Tête à tête" tray		
	Plateau "Tête à tête"		
	Tablett "Tête à tête"		
	Bandeja "Tête à tête"		



312



mm. 1,2 | Antipastiera 4 scomparti in cristallo  
Hors-d'oeuvre tray 4 compt.  
Plat à hors-d'oeuvre 4 comp. cristal  
Vorspeisenplatte 4 Einsatze  
Entremesera

cm. 40,5 x 27,5 | 15<sup>7</sup>/<sub>8</sub>" x 10<sup>3</sup>/<sub>4</sub>"

327



mm. 1,2 | Antipastiera 5 scomparti in porcellana  
China hors-d'oeuvre tray 5 compt.  
Plat à hors-d'oeuvre en porcelaine  
Vorspeisenplatte aus Porzellan 5 Eins.  
Entremesera en porcelana 5 comp.

Ø cm. 31 | Ø 12 1/4"

325



mm. 1,2 | Lasagnera rettangolare  
Set for Lasagne  
Service pour Lasagne  
Set mit Porzellanschale, rech.  
Servicio para Lasagne

cm. 40,5 x 27,5 | 15<sup>7</sup>/<sub>8</sub>" x 10<sup>3</sup>/<sub>4</sub>"  
lt. 3 | oz. 102 1/9

324



mm. 1,2 | Risottiera tonda  
Set for risotti  
Service pour risotto  
Set mit Porzellanschale, rund  
Servicio para arroces

Ø cm. 31 | Ø 12 1/4"  
lt. 2 | oz. 67 3/5

309



mm. 1,2 | Portatovaglioli  
Napkin holder  
Distributeur de serviettes  
Serviettenhalter  
Portaservilletas

cm. 22 x 22 | 8<sup>5</sup>/<sub>8</sub>" x 8<sup>5</sup>/<sub>8</sub>"

31802



mm. 1,2 | Portaspezie  
Aromatic condiments set  
Service pour aromatiques  
condiments  
Gewürzständer  
Servicio para aromaticos y  
condimentos

cm. 15 x 15 | 5 7/8" x 5 7/8"  
H cm. 25,5 | H 10"  
cl. 11 (x 8) | oz. 3 3/4 (x 8)

308



mm. 1,2	Cestino per pane Basket Corbeille Brotschale Cuenco	cm. 22 x 22 cl. 80	8 <sup>5</sup> / <sub>8</sub> " x 8 <sup>5</sup> / <sub>8</sub> " oz. 27
---------	---	-----------------------	---

317

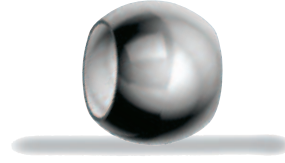

mm. 1,2	Allacciatovaglioli Napkins ring Rond de serviette Serviettenring Servilletero	Ø cm. 6	Ø 2 3/8"
---------	---	---------	----------

306



mm. 1,2	Completo oliera con spargisale Cruet and salt cellar set 4 pcs. Service huile-vinaigre 4 pcs. Essig-/Ölgestell 4-Tlg. Convoy vinagreras con saleros	H cm. 19 cl. 18 (x2) cl. 11 (x2)	H 7 <sup>3</sup> / <sub>8</sub> " oz. 6 (x2) oz. 3 <sup>3</sup> / <sub>4</sub> (x2)
---------	---	--	---

307



mm. 1,2	Formaggera Parmesan cheese basin Fromagère Kasedose Quesera-Azucarero	cl. 20	oz. 6 3/4
---------	---	--------	-----------

310



mm. 1,2	Portabicchieri di carta Paper cup holder Porte-gobelets de papier Papierbecherständer Portavasos de papel	cm. 21 x 11 H cm. 22,8	8 <sup>3</sup> / <sub>16</sub> " x 4 <sup>1</sup> / <sub>4</sub> " H 8 7/8"
---------	---	---------------------------	--

321



mm. 1,2	Portapiatti di plastica Plastic paper plate dispenser Porte-plateau de plastique Stand für Plastik Platten Portaplatos de plastica	Ø cm. 22	Ø 8 5/8"
---------	--	----------	----------





164



mm. 1,2	Vassoio rettangolare Rectangular tray Plateau rectangulaire Tablett, rechteckig Bandeja rectangular	cm. 40 x 29	15 <sup>3</sup> / <sub>4</sub> " x 11 <sup>3</sup> / <sub>8</sub> "
		cm. 49 x 36	19 <sup>1</sup> / <sub>4</sub> " x 14 <sup>1</sup> / <sub>8</sub> "

165



mm. 1,2	Vassoio rotondo Round tray Plateau ronde Tablett, rund Bandeja redonda	Ø cm. 35	Ø 13 <sup>3</sup> / <sub>4</sub> "

168



mm. 1,2	Completo olera con spargisale Cruet and salt cellar set 4 pcs Service huile-vinaigre 4 pièces Essig-/Ölgestell 4-Tlg. Convoy vinagreras con saleros 4 piezas	H cm. 20	H 7 <sup>7</sup> / <sub>8</sub> "
		cl. 18 (x 2)	oz. 6 (x 2)
		cl. 11 (x 2)	oz. 3 <sup>3</sup> / <sub>4</sub> (x 2)

169



mm. 1,2	Formaggera Parmesan cheese basin Fromagère Kasedose Quesera-Azucarero	cl. 20	oz. 6 <sup>3</sup> / <sub>4</sub>

166

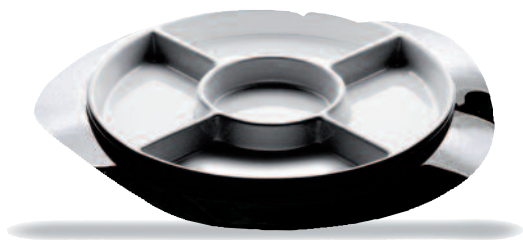

mm. 1,2	Antipastiera 5 scomparti porcell. China hors- d'oeuvre tray 5 compt. Plat à hors-d'oeuvre 5 comp. Vorspeisenplatte 5 Einsätze Entremesera 5 comp.en porcel.	Ø cm. 35	Ø 13 <sup>3</sup> / <sub>4</sub> "

186



mm. 1,2	Cestino semitraforato Half fretworked basket Corbeille demi-ajouré Früchekorb, halbgelocht Frutero semiperforado	Ø cm. 24	Ø 9 <sup>1</sup> / <sub>2</sub> "



408



mm. 1,2	TALAMO Vassoio rettangolare Rectangular tray Plateau rectangulaire Tablett, rechteckig Bandeja rectangular	cm. 29 x 23	11 <sup>3</sup> / <sub>8</sub> " x 9"
		cm. 47 x 37	18 <sup>1</sup> / <sub>2</sub> " x 14 <sup>1</sup> / <sub>2</sub> "

409



mm. 1,2	TALAMINO Vassoio quadrato Square tray Plateau carré Tablett, viereckig Bandeja cuadrada	cm. 37 x 37	14 <sup>1</sup> / <sub>2</sub> " x 14 <sup>1</sup> / <sub>2</sub> "

406

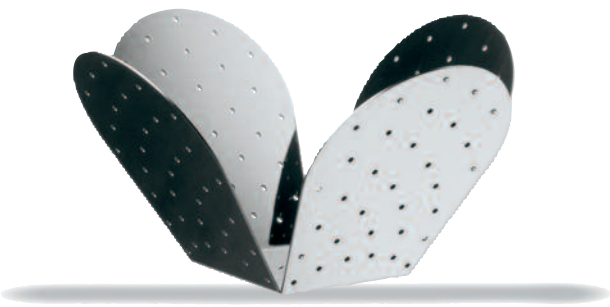

mm. 1,2	BOCCIOLIO Cestino Basket Corbeille Obstschale Frutero	Ø cm. 24,5	Ø 9 <sup>2</sup> / <sub>3</sub> "
		H cm. 13,5 lt. 4	H 5 <sup>1</sup> / <sub>3</sub> " gal. 1

407

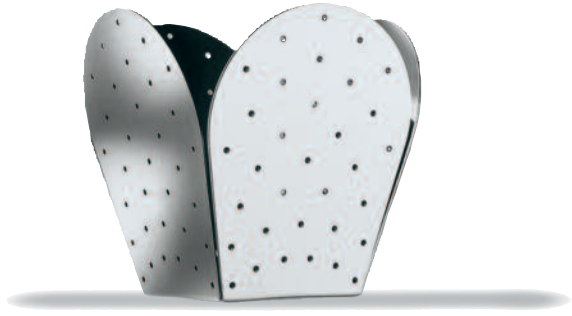

mm. 1,2	BOCCIOLINO Cestino Basket Corbeille Obstschale Frutero	Ø cm. 16,5	Ø 6 <sup>1</sup> / <sub>2</sub> "
		H cm. 15,5 lt. 2,64	H 6 <sup>1</sup> / <sub>9</sub> " oz. 89 <sup>1</sup> / <sub>4</sub>

410



mm. 1,2	COROLLA Completo oliera con spargisale Cruet and salt cellar set Service huile-vinaigre Essig-/Ölgestell 4-Tlg. Convoy vinagreras con saleros H cm. 20- cl.18(x2) cl.11(x2) H 7 <sup>7</sup> / <sub>8</sub> " - oz.6(x2) oz.3 <sup>3</sup> / <sub>4</sub> (x2)	PISTILLA Formaggera Parmesan cheese basin Fromagère Käsedose Quesera-Azucarero cl. 20 oz. 6 <sup>3</sup> / <sub>4</sub>	

505



mm. 1,2	COROLLA Cestello portacondimenti Basket for aromatic condiments Corbeille pour aromatiques condiments Essig-und Öl Flaschenhalter Cesto para aromaticos y condimentos	H cm. 20	H 7 <sup>7</sup> / <sub>8</sub> "
		cl.25(x2) cl.11(x2)	oz.8 <sup>1</sup> / <sub>2</sub> (x2) oz.3 <sup>3</sup> / <sub>4</sub> (x2)

331

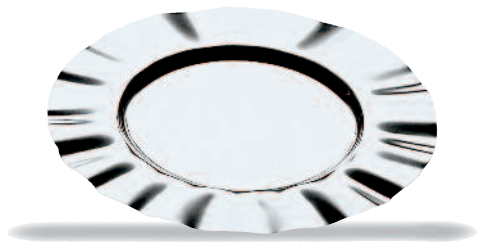

mm. 1,2 | Sottopiatto  
Charger  
Assiette de bienvenue  
Platzteller  
Bajo plato | Ø cm. 33 | Ø 13"

333

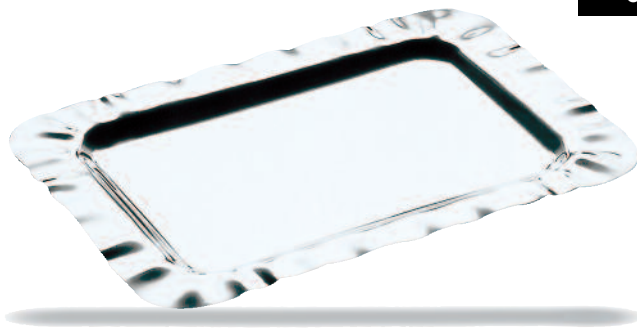

mm. 1,2 | Vassoio rettangolare  
Rectangular tray  
Plateau rectangulaire  
Tablett, rechteckig  
Bandeja rectangular | cm. 50 x 34 | 19<sup>5</sup>/<sub>8</sub>" x 13<sup>3</sup>/<sub>8</sub>"

332

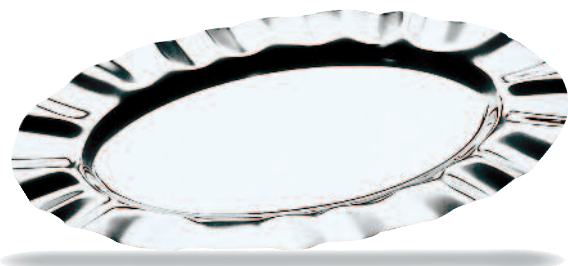

mm. 1,2 | Vassoio ovale  
Oval tray  
Plateau oval  
Tablett, oval  
Bandeja oval | cm. 49 x 33 | 19<sup>1</sup>/<sub>4</sub>" x 13"

337

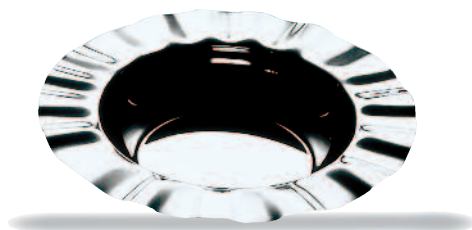

mm. 1,2 | Cestino tondo  
Round basket  
Corbeille ronde  
Obstschale, rund  
Frutero redondo | Ø cm. 31 | Ø 12<sup>1</sup>/<sub>4</sub>"  
cl. 125 | oz. 42<sup>1</sup>/<sub>4</sub>

335



mm. 1,2 | Completo oliera con spargisale  
Cruet and salt cellar set  
Service huile-vinaigre  
Essig-/Ölgestell 4-Tlg.  
Convoy vinagreras con saleros  
H cm. 21- cl.22,5(x2) cl.7,5(x2)  
H 8<sup>1</sup>/<sub>4</sub>" - oz.7<sup>1</sup>/<sub>2</sub>(x2) oz.2<sup>1</sup>/<sub>2</sub>(x2)

336



Formaggera  
Parmesan cheese basin  
Fromagère  
Käsedose  
Quesera-Azucarero  
cl. 20  
oz. 6<sup>3</sup>/<sub>4</sub>

334



mm. 1,2 | Antipastiera 5 scomparti cristallo  
Hors d'oeuvre tray 5 compt.  
Plat à hors-d'oeuvre 5 comp. cristal  
Vorspeisenplatte 5 Einsätze  
Entremesera 5 cristales | Ø cm. 33 | Ø 13"



201



mm. 1,2	Vassoio	cm. 30 x 24	11 <sup>3</sup> / <sub>4</sub> " x 9 <sup>1</sup> / <sub>2</sub> "
	Tray	cm. 40 x 31	15 <sup>3</sup> / <sub>4</sub> " x 12 <sup>1</sup> / <sub>4</sub> "
	Plateau	cm. 50 x 39	19 <sup>5</sup> / <sub>8</sub> " x 15 <sup>3</sup> / <sub>8</sub> "
	Tablett		
	Bandeja		

202

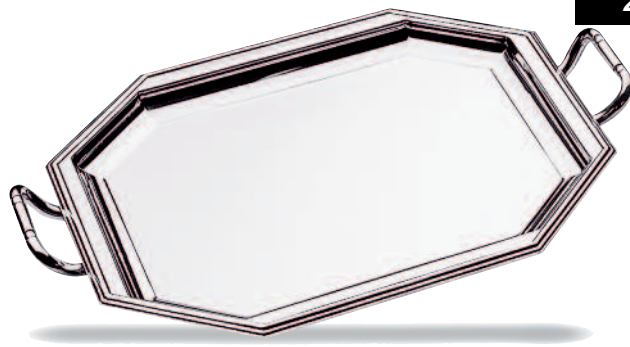

mm. 1,2	Vassoio con maniglie	cm. 40 x 31	15 <sup>3</sup> / <sub>4</sub> " x 12 <sup>1</sup> / <sub>4</sub> "
	Tray with handles	cm. 50 x 39	19 <sup>5</sup> / <sub>8</sub> " x 15 <sup>3</sup> / <sub>8</sub> "
	Plateau avec anses		
	Tablett mit Griffen		
	Bandeja con asas		

203



mm. 1,2	Vassoio	Ø cm. 25	Ø 9 <sup>7</sup> / <sub>8</sub> "
	Tray	Ø cm. 31	Ø 12 <sup>1</sup> / <sub>4</sub> "
	Plateau		
	Tablett		
	Bandeja		

199

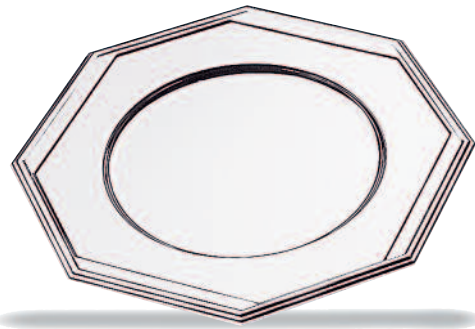

mm. 1,2	Sottopiatto	Ø cm. 31	Ø 12 <sup>1</sup> / <sub>4</sub> "
	Charger		
	Assiette de bienvenue		
	Platzteller		
	Bajo plato		

716



mm. 0,8	Plattino per burro con coperchio e griglia	Ø cm. 9	Ø 3 <sup>1</sup> / <sub>2</sub> "
	Butter dish with inserted grill and cover	cl. 25	oz 8 <sup>1</sup> / <sub>2</sub>
	Beurrer avec grill et couvercle		
	Butterkühler mit Einsatzsieb und Deckel		
	Plato para mantequilla con rejilla y tapa		

210

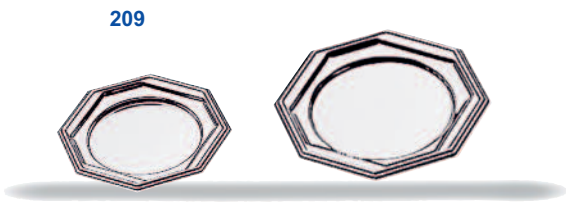

mm. 0,8	Sottobicchiere e sottobottiglia	Ø cm. 10,5	Ø 4 <sup>1</sup> / <sub>8</sub> "
	Glass and bottle coaster	Ø cm. 12,5	Ø 4 <sup>7</sup> / <sub>8</sub> "
	Dessous de verre et de bouteille		
	Glasuntersatz - Flaschenteller		
	Posavaso y Posabotella		

502



mm. 0,8 | Completo oliera con spargisale  
Cruet and salt cellar set  
Service huile-vinaigre 4 pièces  
Essig-/Ölgestell 4-Tlg.  
Convoy vinagreras con saleros 4 pzs

H cm. 21 | H 8 1/4"  
cl. 22,5 (x 2) | oz. 7 1/2 (x 2)  
cl. 7,5 (x 2) | oz. 2 1/2 (x 2)

522



mm. 0,8 | Formaggera  
Parmesan cheese basin  
Fromagère  
Käsedose  
Quesera-Azucarero

cl. 20 | oz. 6 3/4

207/5



mm. 1,2 | Antipastiera 5 scomparti in porcellana  
China hors d'oeuvre tray 5 compt.  
Plat à hors-d'oeuvre 5 comp. en porc.  
Vorspeisenplatte 5 Einsätze  
Entremesera 5 comp.en porcelana

Ø cm. 31 | Ø 12 1/4"

848



mm. 1,2 | Portabon bon con coperchio  
Round candy bowl with lid  
Legumière avec couvercle  
Bonbonsschale mit Deckel  
Portacaramelos con tapa

Ø cm. 25 | Ø 9 7/8"  
cl. 150 | oz. 50 3/4

844

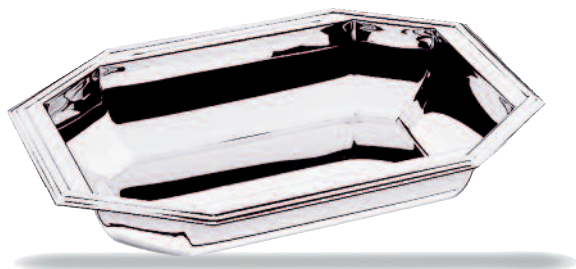

mm. 1,2 | Cestino rettangolare  
Rectangular basket  
Corbeille rectangulaire  
Obstschale rechteckig  
Panera rectangular

cm. 30 x 24 | 11 3/4" x 9 1/2"  
cl. 200 | oz. 67 5/8

843



mm. 1,2 | Cestino  
Round Basket  
Corbeille  
Obstschale  
Frutero

Ø cm. 25 | Ø 9 7/8"  
cl. 150 | oz. 50 3/4  
Ø cm. 31 | Ø 12 1/4"  
cl. 250 | oz. 84 1/2



103



mm. 1,2	Sottopiatto	Ø cm. 33	Ø 13"
	Charger	Ø cm. 35	Ø 13 3/4"
	Assiette de bienvenue		
	Platzteller		
	Bajo plato		

292



mm. 1,2	Servizio per zucchero con cristallo	Ø cm. 33	Ø 13"
	Sugar set with crystal	cl. 15(x3)	oz. 5(x3)
	Service à sucre avec cristal		
	Zuckerständer mit Kristalleinsätzen		
	Servicio para azúcar con cristales		

294



mm. 1,2	Porta pasticcini con piedistallo	Ø cm. 19	Ø 7 1/2"
	Petit-fours stand with base	H cm. 14,5	H 5 3/4"
	Porte-petits-fours avec socle		
	Petit Fours-Ständer	Ø cm. 24	Ø 9 1/2"
	Porta dulces con pedestal	H cm. 14,5	H 5 3/4"

7003/A



mm. 1,2	Alzata portafrutta 2 piani	Ø cm. 24	Ø 9 1/2"
	Fruit holder 2 layers	Ø cm. 31	Ø 12 1/4"
	Serviteur 2 etages	H cm. 24,5	H 9 5/8"
	Etagere 2 stufig		
	Frutero 2 pisos		

293



mm. 1,2	Porta pasticcini con piedistallo 2 Piani	Ø cm. 12	Ø 4 3/4"
	Petit-fours stand with base 2 Layers	Ø cm. 19	Ø 7 1/2"
	Porte-petits-fours avec socle 2 Etages	H cm. 27	H 10 5/8"
	Mokkaetagerer 2 Ebenen		
	Porta dulces con pedestal 2 Pisos		

7003/B



mm. 1,2	Alzata portafrutta 3 piani	Ø cm. 19	Ø 7 1/2"
	Fruit holder 3 layers	Ø cm. 24	Ø 9 1/2"
	Serviteur 3 etages	Ø cm. 31	Ø 12 1/4"
	Etagere 3 stufig	H cm. 35,5	H 14"
	Frutero 3 pisos		

849



mm. 1,2	Cestino per frutta secca con rompinoci Bowl with nut crackers Corbeille à fruit secs avec casse-noix Nusschale mit Nussknacher Frutero con rompenueces	Ø cm. 20 cl. 150	Ø 7 7/8" oz. 50 3/4
---------	--	---------------------	------------------------

715



mm. 0,8	Piattino per burro con coperchio e griglia Butter dish with inserted grill and cover Beurrier avec grille et couvercle Butterdose mit Einsatzsieb und Deckel Plato para mantequilla con rejilla y tapa	Ø cm. 9 cl. 20	Ø 3 1/2" oz. 6 3/4
---------	--	-------------------	-----------------------

105



mm. 1,2	Sottobicchiere Glass coaster Dessous de verre Glasuntersatz Posavasos	Ø cm. 10	Ø 4"
---------	---	----------	------

106



mm. 1,2	Sottobottiglia Bottle coaster Dessous de bouteille Flaschenteller Posabotella	Ø cm. 12	Ø 4 3/4"
---------	---	----------	----------

208

NEW



mm. 1,2	Piattino per pane Bread tray Plat pour pan Brot Platte Plato para pan	Ø cm. 14	Ø 5 1/2"
---------	---	----------	----------

204



mm. 1,2	Porta macaron Macarons server Porte macarons Macaronsträger Porta macaron	Ø cm. 15 H cm. 11,5 cl. 20	Ø 5 7/8" H 4 1/2" oz. 6 3/4
---------	---	----------------------------------	-----------------------------------



497



mm. 1,2 | Completo olera con spargisale 5 pz.  
Cruet and salt cellar set 5 pcs  
Service huile-vinaigre 5 pièces  
Essig-Ölgestell 5-Tlg.  
Vinagreras 5 pza

H.cm.21  
cl. 30 (x2)  
cl. 8 (x3)

H. 8 1/4"  
oz. 10 1/8 (x2)  
oz. 2 3/4 (x3)

509



mm. 1,2 | Completo olera con spargisale 4 pz.  
Cruet and salt cellar set 4 pcs  
Service huile-vinaigre 4 pièces  
Essig-Ölgestell 4-Tlg.  
Vinagreras 4 pza

H.cm.21  
cl. 30 (x2)  
cl. 8 (x2)

H. 8 1/4"  
oz. 10 1/8 (x2)  
oz. 2 3/4 (x2)

508



mm. 1,2 | Olera  
Cruet  
2 pièces huile-vinaigre  
Essig-Ölgestell 2 Tlg.  
Vinagreras 2 pza

H.cm.21  
cl. 30 (x2)

H. 8 1/4"  
oz. 10 1/8 (x2)

510



mm. 1,2 | Spargisale portastecchi con base  
Salt cellar w/toothpick container w/base  
Sel, poivre, porte cure-dents a/socle  
Salz-Pfeffer-Zahnstocherbehälter 3-tlg.  
Sal & Pimenta & palillero 3 pza

H. cm.14  
cl. 8 (x3)

H. 5 1/2"  
oz. 2 3/4 (x3)

350



Cristallo per spargisale art. 510  
Salt and pepper container for art. 510  
Cristal pour art. 510  
Ersatzglass für Art. 510  
Cristal por saleros art. 510  
cl. 8  
oz. 2 3/4

Ampolla  
Cruet  
Huilliere  
Öl-/Essigflasche  
Vinagrera  
H cm. 18 - cl. 30  
H 7 1/8" - oz. 10 1/8

510ST



Portastecchi senza base  
Toothpick container w/out base  
Porte cure-dents sans/socle  
Zahnstocherbehälter ohne Fuß  
Palillero sin pedestal

cl. 8

oz. 2 3/4

611



mm. 1,2 | Formaggera  
Parmesan cheese basin  
Fromagère  
Käsedose  
Quesera - Azucarero | cl. 20 | oz. 6 3/4

512



430491SS

Cristallo per spargisale art. 512-602  
Crystal glass container for art. 512-602  
Cristal avec capsule pour art. 512-602  
Erzatzglass mit Kapsel für art. 512-602  
Cristal por saleros art. 512-602  
cl. 11 - oz. 3 3/4

mm. 1,2 | Spargisale-portastecchi  
Salt cellar with toothpick container  
Sel + poivre + cure dents  
Salz-Pfeffer-Zahnstocherbehälter  
Saleros y pimenteros y pallero  
H. cm. 14 - cl. 11(x2)  
H. 5 1/2" - oz. 3 3/4 (x2)

602



mm. 1,2 | Completo olera con spargisale  
Cruet and salt cellar set  
Service huile-vinaigre 4 pièces  
Essig-Ölgestell 4-tlg.  
Convoy vinagreras con saleros | H. cm 19  
cl. 18(x2)  
cl. 11(x2) | H. 7 1/2"  
oz. 6(x2)  
oz. 3 3/4(x2)

601



430491

mm. 1,2 | Oliera  
Cruet  
2 pièces huile-vinaigre  
Essig-Ölgestell  
Vinagreras

H. cm 19  
cl. 18(x2)  
oz. 6(x2)

603



430603

mm. 1,2 | Oliera portacondimenti  
Cruet for aromatic condiments  
Huilière pour aromatiques condiments  
Gewürzmenage  
Vinagreras para aromaticos  
y condimentos | H. cm 14,5  
cl. 11(x2) | H. 5 3/4"  
oz. 3 3/4(x2)

604



mm 1,2 | Portamarmellata a 3 scomparti  
Jam pack holder 3 compt.  
Porte-confiture 3 comp.  
Marmeladegestell 3 Einsätze  
Marmeladero 3 comp.  
H. cm. 19 - H. 7 1/2"

304



604

mm. 1,2 | Oliera a 3 pezzi  
Cruet 3 pcs  
Huilière 3 pcs  
Menage 3-Tlg.  
Vinagreras 3 pzas  
H. cm. 19 -cl.18(x2)-cl. 11  
H. 7 1/2" - oz.6(x2) oz.3 3/4







231



mm. 0,8	Piatto ovale da portata bordo rinforzato	cm. 25 x 17	9 7/8" x 6 3/4"
	Oval serving plate with reinforced edges	cm. 30 x 21	11 3/4" x 8 1/4"
	Plat oval de service bord renforcé	cm. 35 x 24	13 3/4" x 9 1/2"
	Bratenplatte oval	cm. 40 x 27	15 3/4" x 10 5/8"
	Fuente ovalada borde reforzado	cm. 45 x 32	17 3/4" x 12 5/8"
		cm. 50 x 35	19 5/8" x 13 3/4"
	cm. 60 x 41	23 5/8" x 16 1/8"	

241



mm. 0,8	Piatto ovale da portata pesce bordo rinforzato	cm. 55 x 24
	Oval serving fish plate with reinforced edges	cm. 70 x 29
	Plat à poisson oval bord renforcé	21 5/8" x 9 1/2"
	Fischplatte, oval	27 1/2" x 11 3/8"
	Fuente pescado borde reforzado	

233



mm. 1,2	Piatto ovale da portata mod. pesante	cm. 30 x 22	11 3/4" x 8 5/8"
	Oval serving plate with reinforced edges heavy mod.	cm. 35 x 26	13 3/4" x 10 1/2"
	Plat oval de service bord renforcé Mod. pesant	cm. 40 x 28	15 3/4" x 11"
	Bratenplatte, oval, schweres Mod.	cm. 45 x 31	17 3/4" x 12 1/4"
	Fuente ovalada nuevo modelo	cm. 50 x 34	19 5/8" x 13 3/8"

243



mm. 1,2	Piatto ovale da portata pesce mod. pesante	cm. 55 x 25
	Oval serving fish plate heavy weight	cm. 70 x 27
	Plat à poisson modèle Pesant	21 5/8" x 9 7/8"
	Fischplatte, oval, schweres Mod.	27 1/2" x 10 5/8"
	Fuente ovalada pescado nuevo modelo	

251



mm. 0,8	Piatto rotondo da portata bordo rinforzato	Ø cm. 27	Ø 10 5/8"
	Round serving plate with reinforced edges	Ø cm. 30	Ø 11 3/4"
	Plat rond de service bord renforcé	Ø cm. 35	Ø 13 3/4"
	Bratenplatte, rund	Ø cm. 40	Ø 15 3/4"
	Bandeja redonda borde reforzado		

269



mm. 0,8	Copripiatto sovrapponibile	GALA	Ø cm.28	Ø 11"
	Stackable cover for round plate	»		
	Couvre-plat	»		
	Stapelbarer Teller cloche	»		
	Cubre platos	»		



263



mm. 0,8 | Piatto tondo per legumi a 3 sc. | Ø cm. 27 | Ø 10 5/8"  
 3 sections vegetable dish  
 Plat à légumes rond - 3 compt.  
 Teller rund 3 Abteilungen  
 Bandeja para legumbres 3 comp.

264



mm. 0,8 | Coperchio per piatto tondo art. 263 | Ø cm. 25 | Ø 9 7/8"  
 Lid for art. 263  
 Couvercle pour plat rond art. 263  
 Deckel für Teller 3 Abtlg.  
 Tapa para bandeja redonda art. 263

266



mm. 0,8 | Piatto ovale per legumi a 2 sc. | cm. 30 x 21 | 11 3/4" x 8 1/4"  
 2 section vegetable dish  
 Plat à légumes oval - 2 comp.  
 Teller oval, 2 Abteilungen  
 Bandeja para legumbres 2 comp.

267



mm. 0,8 | Coperchio per piatto ovale art. 266 | cm. 27 x 18 | 10 5/8" x 7 1/8"  
 Lid for art. 266  
 Couvercle pour plat oval art. 266  
 Deckel für Teller, 2 Abtlg.  
 Tapa para bandeja ovalada art. 266

235



mm. 1,2 | Vassoio per gratin | cm. 35 x 20 | 13 3/4" x 7 1/8"  
 Tray for "gratin" | cm. 40 x 24 | 15 3/4" x 9 1/2"  
 Plat à "gratin"  
 Gratinplatte  
 Bandeja gratinar  
 15 3/4" x 9 1/2"

236



mm. 0,8 | Coperchio per Art. 235 | cm. 35 x 20 | 13 3/4" x 7 1/8"  
 Lid for Art. 235 | cm. 40 x 24 | 15 3/4" x 9 1/2"  
 Couvercle pour Art. 235  
 Deckel für Art. 235  
 Tapa para Art. 235

253



mm. 0,8	Cloche per piatto rotondo	Ø cm. 27	Ø 10 5/8"
	Cloche for round plate	Ø cm. 35	Ø 13 3/4"
	Cloche pour plat rond	Ø cm. 40	Ø 15 3/4"
	Tellercloche für Bratenplatte rund		
	Tapa para fuente redonda		

245



mm. 0,8	Cloche per piatto ovale	cm. 30	11 3/4"
	Cloche for oval plate	cm. 35	13 3/4"
	Cloche pour plat oval de service	cm. 40	15 3/4"
	Tellercloche für Bratenplatte oval	cm. 45	17 3/4"
	Tapa para fuente ovalada	cm. 50	19 5/8"

211



mm. 0,6	Vassoio rettangolare per pasticceria	cm. 26 x 19	10 1/4" x 7 1/2"
		cm. 31 x 21	12 1/4" x 8 1/4"
	Rectangular tray for cakes		
	Plat à tarte rectangulaire		
	Gebäckplatte, rechteckig		
	Bandeja		

238



mm. 1,2	Vassoio per gratin e gastronomia	cm. 25 x 18	9 7/8" x 7 1/8"
		cm. 30 x 22	11 3/4" x 8 5/8"
		cm. 35 x 25	13 3/4" x 9 7/8"
		cm. 40 x 29	15 3/4" x 11 3/8"
		cm. 45 x 31	17 3/4" x 12 1/4"
	Tray for "Gratin-gastronomy"		
	Plat à "Gratin et gastronomie"		
	Gratinplatte für Gastronomie		
	Bandeja para gratinar y gastronomia		

247



mm. 0,8	Cloche con pomolo per sottopiatto	Ø cm. 10,5	Ø 4 1/16"		
		Ø cm. 13	Ø 5 1/16"		
		Ø cm. 20	Ø 7 7/8"		
		Ø cm. 22	Ø 8 5/8"		
		Ø cm. 24	Ø 9 1/2"		
		Ø cm. 26	Ø 10 1/4"		
		Ø cm. 28	Ø 11"		
		Ø cm. 31	Ø 12 1/8"		
		Ø cm. 32	Ø 12 5/8"		
			Cloche with knob for under plate		
			Cloche pour sous-assiette		
	Tellercloche				
	Tapa para fuente redonda				

268



mm. 0,8	Copripiatto sovrapponibile	Ø cm. 20	Ø 7 7/8"		
		Ø cm. 24	Ø 9 1/2"		
		Ø cm. 26	Ø 10 1/4"		
		Ø cm. 27	Ø 10 5/8"		
		Ø cm. 28	Ø 11"		
		Ø cm. 30	Ø 11 3/4"		
		Ø cm. 31	Ø 12 3/8"		
		Ø cm. 33	Ø 13"		
			Stackable cover for round plate		
			Couvre-plat		
	Stapelbarer Tellercloche				
	Cubre platos				





272



mm. 0,8  
 Piatto termico con copripiatto e ciambella termica  
 Insulated plate with cover and thermal serving unit  
 Plat thermique avec couvre-plat et disque thermique  
 Warmhalteteller mit Tellerlocke und Thermikelement  
 Plato térmico con cubre platos y bobina térmica

Ø cm. 28,5  
 Ø cm. 30,5  
 Ø cm. 33,7

Ø 11 1/4"  
 Ø 12"  
 Ø 13 1/4"

273



mm. 0,8  
 Piatto termico con cloche e ciambella termica  
 Insulated plate with cloche and thermal serving unit  
 Plat thermique avec cloche et disque thermique  
 Warmhalteteller mit Tellerlocke und Thermikelement  
 Plato térmico con tapadera y bobina térmica

Ø cm. 28,5  
 Ø cm. 30,5  
 Ø cm. 33,7

Ø 11 1/4"  
 Ø 12"  
 Ø 13 1/4"

**A** Ø cm. 28 - 30  
 Ø 11" - 11 3/4"

**B** Ø cm. 28 - 30  
 Ø 11" - 11 3/4"

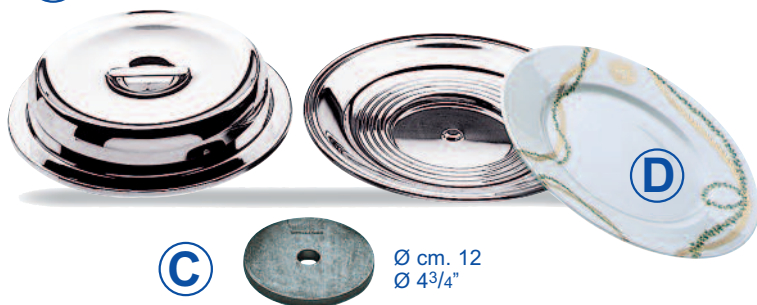

**C** Ø cm. 12  
 Ø 4 3/4"

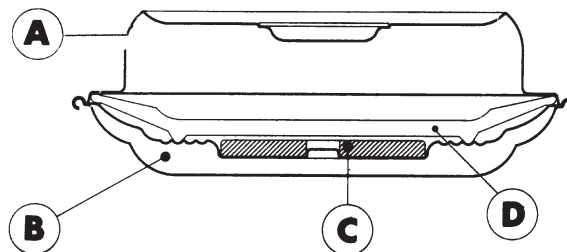

La ciambella termica © è usata per mantenere a lungo le temperature calde o fredde.

Nel primo caso va riscaldata in forno ad una temperatura variabile tra i 60°C ed i 150°C; nel secondo caso in Freezer a -14°C. In queste condizioni è in grado di mantenere la temperatura desiderata (da -5°C a +50°C) per un periodo che varia dai 20 ai 30 minuti.

The Thermal serving unit © maintains food at hot or cold temperatures for about 30 minutes.

The disk can be placed in an oven at 140°C (302°F) or in a freezer at -14°C (-57°F).

Le disque thermique © est utilisé pour maintenir la chaleur ou le froid. Dans un cas, le disque est préchauffé dans le four à une température variant de 60°C à 150°C. Dans un second cas, le disque peut être refroidi jusqu'à -14°C. Dans ces conditions, le disque est en mesure de maintenir la chaleur ou la fraîcheur pendant un temps variable de 20 à 30 minutes, à la température voulue (de -5°C à -50°C).

Der Warmhalteteller mit Thermikelement dient zum Servieren von warm- oder kalzuhaltenden Speisen, also sowohl zur Speicherung von Wärme als auch von Kälte. Zum Warmhalten erhitzt man das runde Thermikelement im Ofen auf 60° bis 150° C. Zum Kalthalten kühlt man im Gefrierfach das runde Thermikelement auf -14° C ab. Derart eingefügt in die die Vertiefung des Warmhaltetellers kann man Speisen bis zu 30 min bei einer gewünschten Temperatur zwischen -5° C und +50° C warm halten.

La bobina térmica © puede ser utilizada para mantener el calor o el frío. En el primer caso se calienta en el horno a una temperatura variable entre 60°C y 150°C; en el segundo, se mete en un congelador a -14°C. En estas condiciones es capaz de mantener los alimentos calientes o fríos durante un periodo que oscila entre 20 y 30 minutos a la temperatura deseada (de -5° C a +50° C).

Una rivoluzionaria soluzione per un servizio ai piani di alta classe, nella massima sicurezza anti-incendio, evitando l'uso di fiamme o fornelli.

A revolutionary solution for room service, eliminating the need of fuel or electric wires.

C'est une solution révolutionnaire pour un Service à l'Étage de qualité en conformité avec les règles de sûreté anti-incendie et en évitant l'usage de flammes ou feux ouverts.

Dies ist eine revolutionäre Lösung für den hohen Anspruch an excellenten Zimmerservice. Man vermeidet dabei den Gebrauch von offenem Feuer oder elektrischen Platten und vermeidet Konflikte mit den Brandschutzrichtlinien der jeweiligen Länder

Es una solución revolucionaria para un servicio de habitación de alta calidad que respeta las normas de seguridad contra incendios, pues evita el peligro de l'uso de llamas y hornillos encendidos.



732



mm. 1,2	Zuppiera nuovo modello	Ø cm. 14 - lt. 0,6	Ø 5 1/2" - oz. 20 1/4
	Soup tureen new mod.	Ø cm. 18 - lt. 1,2	Ø 7" - oz. 40 5/8
	Soupière nouveau modele	Ø cm. 20 - lt. 1,8	Ø 7 7/8" - oz. 60 7/8
	Suppenterrine neues Mod.	Ø cm. 22 - lt. 2,5	Ø 8 5/8" - oz. 84 1/2
	Sopera nuevo Modelo	Ø cm. 24 - lt. 3,1	Ø 9 1/2" - oz. 104 7/8
		Ø cm. 26 - lt. 3,9	Ø 10 1/4" - oz. 131 7/8
	Ø cm. 28 - lt. 5,1	Ø 11" - gal. 1 1/4	

782



mm. 1,2	Legumiera nuovo modello	Ø cm. 14 - lt. 0,6	Ø 5 1/2" - oz. 20 1/4
	Vegetable dish new model	Ø cm. 18 - lt. 1,2	Ø 7" - oz. 40 5/8
	Lègumiere nouveau modele	Ø cm. 20 - lt. 1,8	Ø 7 7/8" - oz. 60 7/8
	Lègumier neues Modell	Ø cm. 22 - lt. 2,5	Ø 8 5/8" - oz. 84 1/2
	Legumbrera nuevo Modelo	Ø cm. 24 - lt. 3,1	Ø 9 1/2" - oz. 104 7/8
		Ø cm. 26 - lt. 3,9	Ø 10 1/4" - oz. 131 7/8
	Ø cm. 28 - lt. 5,1	Ø 11" - gal. 1 1/4	

736



mm. 1,2	Coperchio per art. 732 - 782	Ø cm. 14	Ø 5 1/2"
	Lid for art. 732 - 782	Ø cm. 18	Ø 7"
	Couvercle pour art. 732 - 782	Ø cm. 20	Ø 7 7/8"
	Deckel für art. 732 - 782	Ø cm. 22	Ø 8 5/8"
	Tapa para art. 732 - 782	Ø cm. 24	Ø 9 1/2"
		Ø cm. 26	Ø 10 1/4"
	Ø cm. 28	Ø 11"	

701



10131140

mm. 1,2	Salsiera mod. "Aladino"	cl. 10	oz. 3 3/8
	Gravy boat mod. "Aladino"	cl. 15	oz. 5 1/8
	Saucière mod. "Aladino"	cl. 30	oz. 10 1/8
	Sauciere mod. "Aladino"		
	Mestolino per salsa	Lungh. cm. 18,7	Long. 7 3/8"
	Ladle for gravy boat		
	Cuillère à sauce		
	Saucenlöffel		
	Cacillo para salsa		

511



430511SS

mm. 0,8	Completo spargisale-portastecchi	H cm. 14	H 5 1/2"
	Salt-cellar with toothpick container	cl. 8	oz. 2 3/4
	Sel+poivre+porte cure-dents		
	Salz+Pfeffer+Zahnstocherbehälter		
	Saleros y pimentero y palillero		

731



mm. 1,2	Zuppiera monoporzione demitasse	Ø cm 10	Ø 3 7/8"
	Soup cup with base	cl. 23	oz. 8
	Soupiere sur socle avec anses		
	Suppentasse auf Fuss	Ø cm 12	Ø 4 3/4"
	Taza para sopa con pedestal	cl. 35	oz. 11 7/8

772



mm. 0,8 | Molla per ghiaccio  
Ice tongs  
Pince à glaçon  
Eiszange  
Pinzas hielo

Lungh. cm. 15,5  
Length 6 1/8"

778



mm. 2,0 | Molla per ghiaccio  
Ice tongs  
Pince à glaçon  
Eiszange  
Pinzas hielo

Lungh. cm. 18  
Length 7 1/8"

773



mm. 0,8 | Molla per pane  
Bread tongs  
Pince à pain  
Brotzange  
Pinzas pan

Lungh. cm. 18  
Length 7 1/8"

774



mm. 0,8 | Molla per dolci  
Pastry tongs  
Pince à gateaux  
Gebäckzange  
Pinzas dulces

Lungh. cm. 19  
Length 7 1/2"

777



mm. 0,8 | Molla per spaghetti  
Spaghetti/Pasta  
tongs  
Pince à spaghetti  
Spaghettizange  
Pinzas spaghetti

Lungh. cm. 21  
Length 8 1/4"

775

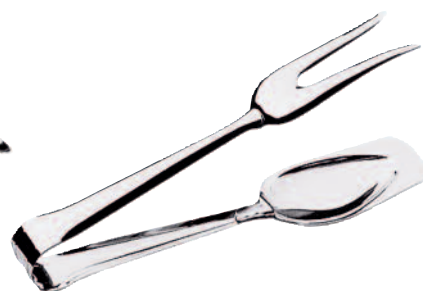

mm. 0,8 | Molla per arrosto e verdure  
Roasts and vegetables tongs  
Pince à salade et à rôti  
Servierzange  
Pinzas asado y verduras

Lungh. cm. 21  
Length 8 1/4"

779



mm. 0,8 | Molla per lumache  
Escargot tongs  
Pince à escargots  
Schneckenzange  
Pinzas para caracoles

Lungh. cm. 16 | Length 6 1/4"

771



mm. 0,8 | Molla per zucchero  
Sugar tongs  
Pince à sucre  
Zuckerzange  
Pinzas azúcar

Lungh. cm. 14 | Length 5 1/2"



752



mm. 0,8	Piattino per lumache	Ø cm. 13,5-6pz.	Ø 5 3/8" - 6pcs.
	Escargot dish	Ø cm. 18 - 12pz.	Ø 7 1/8" - 12pcs
	Molla per lumache	Lungh. cm. 16	Length 6 1/4"
	Tongs for snails		
	Pince à escargots		
	Schneckenzange		
	Pinzas para caracoles		

741



mm. 0,8	Tegamino friggiuova	Ø cm. 16	Ø 6 1/4"
	Frying pan for eggs		
	Plat à oeuf		
	Eierpfanne		
	Plato huevos		

904



mm. 1,2	Posacenere	cm. 14 x 12	5 1/2" x 4 3/4"
	Ash-tray		
	Cendrier		
	Ascher		
	Cenicero		

911



mm. 0,6	Scodella lavadita	Ø cm. 12	Ø 4 3/4"
	Finger bowl	cl. 30	oz. 10 1/8
	Ecuelle		
	Fingerbowl		
	Lavadedos		

956



mm. 1,2	Cloche copriburro o per antipasti	Ø cm. 10,5	Ø 4 1/16"
	Cloche for hors d'oeuvre or butter plate	Ø cm. 13	Ø 5 1/16"
	Cloche dome pour assiette		
	Cloche für Vorspeisen- oder Butterteller		
	Tapa para mantequera o para platos por entremes		

528



mm. 1,2	Formaggera	ODEON	cl. 20	oz. 6 3/4
	Parmesan cheese basin	»		
	Fromagère	»		
	Käsedose	»		
	Quesera-Azucarero	»		

998



Ø mm 8,0 | Portabottiglia  
Bottle stand  
Porte-bouteille  
Rotweinwiege  
Portabotella

H cm. 19 | H 7 1/2"

710

711



mm. 0,6 | Portauovo  
Egg-cup  
Coquetier  
Eierbecher  
Huevera

cm 15x9 | 5 7/8"x3 1/2"

Ø cm 4,5 | Ø 1 3/4"

707



mm. 1,2 | Portaburro  
Butter dish  
Beurrier  
Butterdose mit Deckel  
Mantequera  
cm. 11 x 20  
4 3/8" x 7 7/8"

720



mm. 1,2 | Portaburro e marmellata  
Butter and marmalade dish  
Beurrier et confiturier  
Butter -Marmaladeplatte  
Mantequera y marmeladero  
cm. 17,5 x 7,5  
6 3/4" x 2 7/8"



mm. 1,2 | Ciotola per antipasto UNO  
Snack bowl »  
Bol à snacks »  
Snackschale »  
Cuenco por entremes »  
Ø cm 9  
Ø 3 1/2"

544

504



504

Ø mm. 6,0 | Cestelli portacondimenti da tavola  
Basket for aromatic condiments  
Corbeilles pour condiments aromatiques  
Tisch-Essig/Öl Flaschenhalter  
Cestos para aromaticos y condimentos



503



354

mm. 1,2 | Cestelli portacondimenti da buffet  
Basket for aromatic condiments  
Corbeilles pour condiments aromatiques  
Buffet-Essig/Öl Flaschenhalter  
Cestos para aromaticos y condimentos



355

355



446

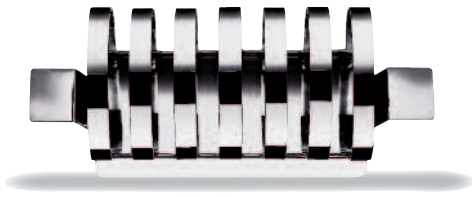

mm. 1,2 | 8 1/2  
 Portatoast  
 Toast rack  
 Porte-toast  
 Toastständer  
 Portatostadas

cm. 21 x 7,5 | 8 1/4" x 3"

671



mm. 1,0 | Vasetto portafiori  
 Flower vase  
 Vase à fleur  
 Blumenvase  
 Florero

H. cm. 14 | H. 5 1/2"

903



mm. 0,6 | Segnaposto  
 Table number stand  
 Numéro de table  
 Tischnummern-Aufsteller  
 Numero de mesa

cm 11 x 9  
 4 3/8" x 3 1/2"

996

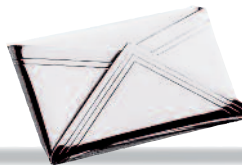

mm. 0,6 | Portanumero  
 Table number stand  
 Numéro de table  
 Tischnummern-Ständer  
 Numero de mesa

cm. 9,5 x 5  
 3 3/4" x 2"



Ø cm.10  
 H cm 10  
 Ø 4"  
 H 4"

901

289



mm.1,2  
 Porta cono patatine  
 Chips cone holder  
 Porte pommes frites  
 Eis-Kartoffenbehälter  
 Porta cono patatas fritas

GALA  
 "  
 "  
 "  
 "

Ø cm.6 - H cm. 10  
 Ø 2" - H 3 7/8"



726  
 mm.1,2  
 Coppa Martini  
 Martini Glass  
 Verre à Martini  
 Martini glas  
 Vaso para Martini  
 cl. 11 - cl. 20  
 oz. 3 3/4 - oz. 6 3/4

727



727  
 mm.1,2  
 Coppa per intermezzo  
 Intermezzo cup  
 Coupe à intermezzo  
 Sorbetschale  
 Copa para intermezzo  
 cl. 4  
 oz. 1 3/8

314



mm. 1,2	Vassoio concavo ERGONOMICA	cm 40 x 19	15 <sup>3</sup> / <sub>4</sub> " x 7 <sup>1</sup> / <sub>2</sub> "
	Crescent tray »	cm 55 x 28	21 <sup>5</sup> / <sub>8</sub> " x 11"
	Plateau concave »		
	Konkave Tablett »		
	Bandeja concavo »		

131



mm. 0,8	Sottopiatto RAFFAELLO	Ø cm. 32,5	Ø 12 <sup>3</sup> / <sub>4</sub> "
	Charger »		
	Assiette de bienvenue »		
	Platzteller »		
	Bajo plato »		

232



mm. 1,2	Vassoio per self service	cm. 40 x 30	15 <sup>3</sup> / <sub>4</sub> " x 11 <sup>7</sup> / <sub>8</sub> "
	Cafeteria tray		
	Plateau pour self service		
	Tablett für self service		
	Bandeja para self service		

448



mm. 1,2	PRATER	cm. 20 x 18	7 <sup>7</sup> / <sub>8</sub> " x 7"
	Portatovaglioli		
	Napkins holder		
	Distributeur de serviettes		
	Serviettenhalter		
	Portaservilletas		

675



mm. 0,8	Portabottiglia antirollio per yacht	Ø cm. 10	H cm. 17
	Yachting non-slip bottle holder		
	Cache eau minerale avec anneau antiderapant	Ø 3 <sup>7</sup> / <sub>8</sub> "	H 6 <sup>5</sup> / <sub>8</sub> "
	Antiroll-Spezialflaschenhalter für Yachten		
	Portabotella antibalanceo para yacht		

905



mm. 0,8	Portagrissini	Ø cm 10	Ø 3 <sup>7</sup> / <sub>8</sub> "
	Bread sticks holder	H cm. 17	H 6 <sup>5</sup> / <sub>8</sub> "
	Porte gressin		
	Grissini-Halter		
	Porta bastoncillos de pan		



229



mm. 1,2 | Portasalse per fiorentina o tartara  
Sauce set for Florentine or Tartar steak  
Service à sauce pour Florentin ou Tartare  
Sauce Set für Florentine oder Tartar Steak  
Servicio para salsa por bistek Tartara y Florentina

cl. 35 (x4) | oz. 117/8 (x4)

230



mm. 1,2 | Completo portasalse per fiorentina o tartara  
Complete sauce set for Florentine or Tartar steak  
Service à sauce complet pour Florentin ou Tartare  
Sauce Set für Florentine oder Tartar Steak  
Servicio para salsa por bistek Tartara y Florentina

cm. 40 x 27 | 15 3/4" x 10 5/8"  
cl. 35 (x4) | oz. 117/8 (x4)

094



mm. 1,2 | Cestino rotondo CAMELLA  
Round basket  
Corbeille ronde  
Obstschale, rund  
Frutero redondo

Ø cm. 27 | Ø 10 5/8"

098



mm. 1,2 | Vassoio CAMELLA  
Tray  
Plateau  
Tablett  
Bandeja

cm. 35 x 23 | 13 3/4" x 9 1/4"  
cm. 40 x 27 | 15 3/4" x 10 5/8"

721



mm. 1,2 | Coppa termica gelato e macedonia  
Insulated ice cream cup/salad fruit bowl  
Coupe thermique a glace et macedonie  
Isolier-Eisfruchtbecher mit Deckel  
Copa térmica helado y macedonia

Ø cm. 27 | Ø 3 1/3"  
cl. 15 | oz. 6

356



mm. 1,2 | Cestello portacondimenti da buffet  
Basket for aromatic condiments  
Corbeille pour condiments aromatiques  
Buffet-Essig/Öl Flaschenhalter  
Cesto para aromaticos y condimentos"

280



mm. 1,2	Set per ceviche in acciaio inossidabile 18/10	<b>607</b>	<b>607</b>
	18/10 Stainless Steel ceviche set	Ø cm. 27	Ø 10 1/2"
	Set pour ceviche en acier inoxydable 18/10	H cm. 13,5	H 5 1/4"
	Cevicheset in Rostfreie Stahl 18/10	lt. 5	gal. 1 1/3
	Cevichera en acero inoxidable 18/10	<b>58922</b>	<b>58922</b>
		Ø cm. 22	Ø 8 1/2"
		H cm. 14	H 5 1/2"
		cl. 220	oz. 74 3/8

281



mm. 1,2	Set per ceviche in policarbonato	<b>58928</b>	<b>58928</b>
	Polycarbonate ceviche set	Ø cm. 28	Ø 11"
	Set pour ceviche en polycarbonate	H cm. 17,3	H 6 5/8"
	Cevicheset in Polikarbonat	lt. 6,03	oz. 202 1/2
	Cevichera en policarbonado	<b>58922</b>	<b>58922</b>
		Ø cm. 22	Ø 8 1/2"
		H cm. 14	H 5 1/2"
		cl. 220	oz. 74 3/8

994C



mm. 1,2	Portanumero piccolo	H cm. 7	H 2 3/4"
	Mini table number stand		
	Numbers etched to order		
	Mini marquer de table		
	Mini Tischnummernständer		
	Porta numero de mesa pequeño		

913



mm. 1,0	Porta badge in acciaio magnetico	cm. 8 x 4,5	3 1/7" x 1 3/4"
	Badge holder in magnetic steel		
	Porte-badge en acier magnétique		
	Badge-Halter in magnetischem Stahl		
	Porta tarjeta de acero magnético		

225



Cloche trasparente	Transparent cloche	Ø cm. 28	Ø 11"
	Cloche transparente		
	Transparente Teller cloche		
	Tapa transparente		

709



mm. 1,2	Portastuzzicadenti con base	cl. 5	oz. 1 3/4
	Toothpick container with base		
	Porte-cure-dents avec socle		
	Zahnstocherbehälter auf Fuss		
	Porta-palillos con base		



047



Colino da cocktail  
Cocktail strainer  
Passoire à cocktail  
Cocktailsieb  
Colador para coctelera

cm. 22 | 8 2/3"

049



Cavatappi  
Cork screw / Bottle opener  
Ouvre boîte - Ouvre-bouteilles  
Korkenzieher  
Abrebotellas

H cm. 19 | H 7 1/2"

025



Grattugia  
Grater  
Râpe  
Reibe  
Rallador

cm. 23 | 9"

048



Schiaccianoci  
Nutcracker  
Casse noix  
Nussknacker  
Rompenueces

cm. 20 | 7 7/8"

473



ATTILA  
Cavatappi  
Cork screw / Bottle opener  
Décapsuleur  
Korkenheber  
Abrebotellas

cm. 10 | 3 7/8"

10001108



mm. 1,2 | Cucchiaino per caviale  
Caviar spoon  
Cuillère à caviar  
Kaviarlöffel  
Cucharita caviar

cm. 11,8 | 4 2/3"

447



JOKER  
Macinapepe  
Pepper mill  
Moulin à poivre  
Pfeffermühle  
Molinillo de pimienta

Ø cm. 4 | Ø 1 1/2"  
H cm. 15 | H 5 7/8"

464



ETNA  
Macinasale  
Salt mill  
Moulin à sel  
Salzmühle  
Molinillo de sal

Ø cm. 4 | Ø 1 1/2"  
H cm. 15 | H 5 7/8"

466



MANOLO  
Macinapeperoncino  
Chilli mill  
Moulin à piment  
Chilimühle  
Molinillo de chile

Ø cm. 4 | Ø 1 1/2"  
H cm. 15 | H 5 7/8"

462



PARDON  
Tagliatartufi  
Truffles slicer  
Coupe truffes  
Trüffel Hobel  
Cortador de trufas

cm. 20 x 8 | 7 7/8" x 3 1/7"





THE GRILL

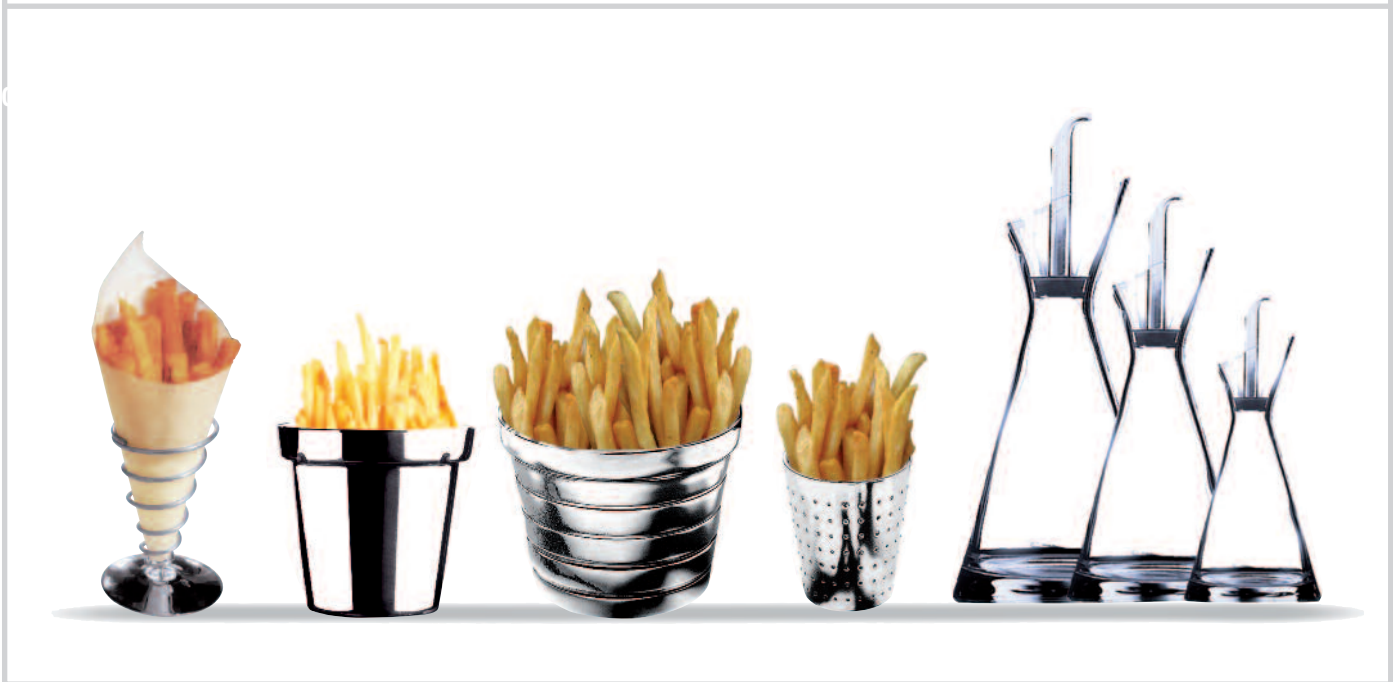



620

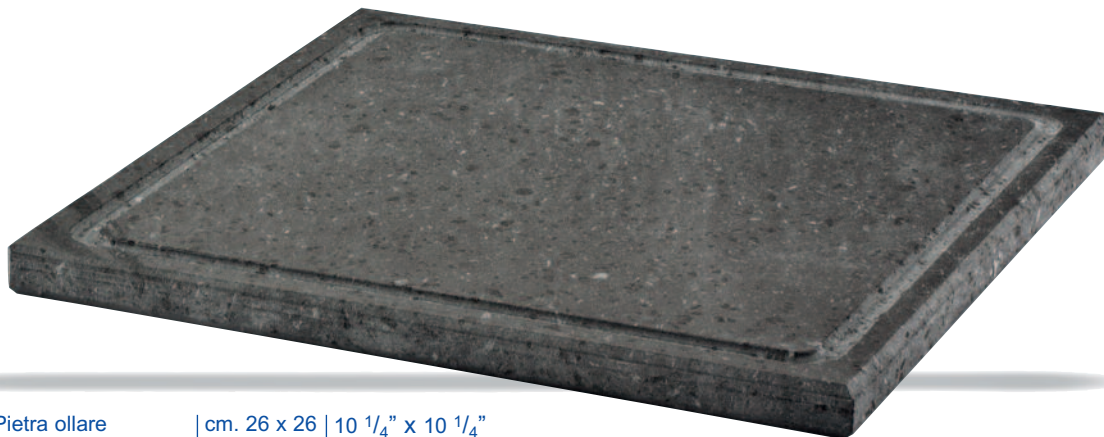

Pietra ollare Soapstone Ardoise Speckstein Pizarra	cm. 26 x 26	10 1/4" x 10 1/4"
--	-------------	-------------------

700



H cm 10	H 4"
cl. 35	oz. 11 7/8

mm.1,2  
Portapatatine fritte  
French fry holder for table  
Porte pommes frites pour table  
Kartoffenbehälter für Tisch  
Porta patatas fritas por mesa

260



Ø cm 10	H 3 3/4"
H cm 9,5	Ø 3 7/8"

289



H cm. 10	H 3 7/8"
Ø cm. 6	Ø 2"

902



H cm 8	H 3 1/4"
Ø cm 7	Ø 2 3/4"

282

NEW



mm. 1,2	Braciere con pietre naturali	Ø cm. 15	Ø 5 7/8"
	Table grill with natural stones	Ø cm. 22	Ø 8 5/8"
	Brasier avec pierres naturelles	Ø cm. 32	Ø 12 5/8"
	Feuerschale mit Natursteine		
	Hoguera c/piedras naturales		

572



Ampolla Cruet Huilliere Öl-/Essigflaschen mit Spender Vinagrera	cl. 20	oz. 6 3/4
	cl. 34	oz. 11 1/2
	cl. 62	oz. 21

1136

10001136



3436

10101136  
10231136



10141136  
10341136  
10201136



Coltello bistecca  
Steak knife  
Couteau entrecôte  
Steakmesser  
Cuchillo bistek

**10001136**  
**UNI**  
cm. 21,3 8 1/4"

**10101136**  
**NORMA**  
**10231136**  
**BOHEME**

cm. 23 9 1/8"

**10141136**  
**ROMA**  
**10201136**  
**MICHELANGELO**  
**10341136**  
**NATURA**

cm. 22,7 8 7/8"

1144

10001144



1145

10001145



Coltello bistecca americano  
American steak knife  
Couteau entrecôte américain  
Amerikanisches Steakmesser  
Cuchillo bistek americano

cm. 25 9 5/8"

mm. 4,0

Forchetta per bistecca  
Steak fork  
Fourchette à entrecôte  
Tranchiergabel  
Tenedor para bistek

cm. 20,3 8"

1146

10001146



Coltello arrosto  
Roast knife  
Couteau rôti  
Tranchiermesser  
Cuchillo asados

cm. 27,5 10 4/5"



574



Antipastiera quadra in vetro | cm. 24,5 x 24,5 | 9<sup>5</sup>/<sub>8</sub>" x 9<sup>5</sup>/<sub>8</sub>"  
 Hors d'oeuvre tray in glass  
 Plat à hors d'oeuvre en verre  
 Vorspeisenplatte aus Glas  
 Entremesera en vidrio

575



Piatto quadro in vetro | cm. 24,5 x 24,5 | 9<sup>5</sup>/<sub>8</sub>" x 9<sup>5</sup>/<sub>8</sub>"  
 Square plate in glass  
 Plateau carré en verre  
 Platte, viereckig, aus Glas  
 Plato cuadrado en vidrio

582



Supporto per | cm. 43 x 14 | 16<sup>7</sup>/<sub>8</sub>" x 5<sup>1</sup>/<sub>2</sub>"  
 Multifunction stand for  
 Support multi-usages pour  
 Schalenhalter  
 Soporte multiuso para

581



Supporto per | cm. 36 x 14 | 14<sup>1</sup>/<sub>8</sub>" x 5<sup>1</sup>/<sub>2</sub>"  
 Multifunction stand for  
 Support multi-usages pour  
 Schalenhalter  
 Soporte multiuso para

570



mm. 1,2 | UNO | Ø cm. 6 | Ø 2<sup>3</sup>/<sub>8</sub>"  
 Cremiera | H cm. 8,8 | H 3<sup>1</sup>/<sub>2</sub>"  
 Cream jug | cl. 16 | oz 5<sup>3</sup>/<sub>8</sub>"  
 Cremiér  
 Sahnegießer  
 Jarrita lechera

594



mm. 1,2 | UNO | Ø cm. 6 | Ø 2<sup>3</sup>/<sub>8</sub>"  
 Cremiera con piedistallo | H cm. 9 | H 3<sup>1</sup>/<sub>2</sub>"  
 Cream jug with base | cl. 16 | oz 5<sup>3</sup>/<sub>8</sub>"  
 Cremiér avec socle  
 Sahnegießer auf Fuss  
 Jarrita lechera con pedestal

576



Servizio per pinzimonio in vetro	Ø cm. 28	Ø 11"
Salad set in glas	H cm. 8	H 3 1/8"
Service pour salade en verre	cl. 300	oz. 101 1/2
Service für Salat aus Glas		
Servicio para ensalada en vidrio		

290576



Servizio per pinzimonio	Ø cm. 28	Ø 11"
Set for salad serving	cl. 300	oz. 101 1/2
Service à crudités		
Set "Salatdressing"		
Servicio para ensaladas		

**Ciambella termica per supporto Milleusi.** La ciambella termica è usata per mantenere a lungo le temperature calde o fredde. Nel primo caso va riscaldata in forno ad una temperatura variabile tra i 160° C ed i 250° C, nel secondo caso va conservata in freezer a -14° C. In queste condizioni e in grado di mantenere la temperatura desiderata (da -5° C a +50° C) per un periodo che varia dai 20 ai 30 minuti

**Thermal serving unit for multifunction stand.**

The thermal serving unit is used to maintain heat or cold. In the first case, it must be heated in an oven at 160° C (+320° F) -250° C (+482° F). In the second case in a Freezer at -14° C (-57° F). In these conditions it is able to maintain the food either hot or cold for a period between 20 and 30 minutes at the desired temperature (from -5° C (-41° F) to +50° C (+122° F)).

**Disque thermique pour support multi-usages.** Le disque thermique est utilisé pour maintenir la chaleur ou le froid. Dans un cas, le disque est préchauffé dans le four à une température variant de 160° C a 250° C. Dans un second cas, le disque peut être refroidi jusqu'à -14° C. Dans ces conditions, le disque est en mesure de maintenir la chaleur ou la fraîcheur pendant un temp variable de 20 a 30 minutes, a la température voulue (de -5° C a +50° C).



583

Ciambella termica per supporti  
Thermal serving unit for stands  
Disque thermique pour support  
Thermische Ringröhre für Hälter  
Bobina térmica para soportes  
Ø cm. 12 - Ø 4 3/4"

**Der Warmhalteteller mit Thermikelement** dient zum Servieren von warm- oder kalzuhaltenden Speisen, also sowohl zur Speicherung von Wärme als auch von Kälte. Zum Warmhalten erhitzt man das runde Thermikelement im Ofen auf 160 bis 250° C. Zum Kalthalten kühlt man im Gefrierfach das runde Thermikelement auf -14° C ab. Derart eingefügt in die Vertiefung des Warmhaltetellers kann man Speisen bis zu 30 min bei einer gewünschten Temperatur zwischen -5° C und +50° C kalt bzw. warm halten.

**Bobina térmica para soporte multiuso.** La bobina térmica puede ser utilizada para mantener el calor o el frío. En el primer caso, se calienta en el horno a una temperatura variable entre 160° C y 250° C; en el segundo, se mete en un congelador a -14° C. En estas condiciones, es capaz de mantener los alimentos calientes o fríos durante un periodo que oscila entre 20 y 30 minutos a la temperatura deseada (de -5° C a +50° C).

582



580



Pirofila ovale in fine china	cm. 37 x 24	14 5/8" x 9 3/8"
Fine china oval bowl	cl. 300	oz. 101 1/2
Plat oval en porcelaine à feu		
Auflaufform, oval aus Porzellan		
Phirophila oval en porcelana		

579



Lasagnera in fine china	cm. 34,5 x 24,5	13 5/8" x 9 5/8"
Fine china Lasagne's bowl	cl. 300	oz. 101 1/2
Plat rectangulaire en porcelaine à feu		
Auflaufform, quadr. aus Porzellan		
Fuente para Lasagne en porcelana		







P



V7

N

O

W

L7



792



Vassoio rettangolare  
Rectangular tray  
Plateau rectangulaire  
Tablett, rechteckig  
Bandeja rectangular

cm. 30 x 20 | 11 3/4" X 7 7/8"  
cm. 50 x 32 | 19 3/4" X 12 3/4"

795



Tovaglietta americana  
Place mat  
Set de table americain en bois  
Tischset aus Holz  
Individual en madera

cm. 38 x 28 | 15" x 11"

796



Sottopiatto  
Charger  
Assiette de bienvenue  
Platzteller,  
Bajo plato

Ø cm. 33 | Ø 13"

791



Vassoio/Sottopiatto  
Square Tray/Charger  
Plateau/Assiette de bienvenue  
Tablett/Platzteller,  
Bandeja/Bajo plato

cm. 32 x 32 | 12 3/4" x 12 3/4"

791AC

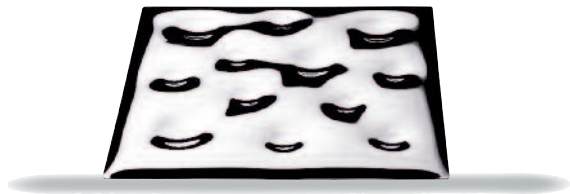

Inserto Finger Food per vassoio quadro e rettangolare  
Finger Food insert for square and rectangular tray  
Insért Finger Food pour plateau carré et rectangulaire  
Finger Food-Einsatz für quadratische/rechteckig Schale  
Inserto para Finger Food por bandeja cuadrada y rectangular

cm. 30 x 30 | 11 7/8" x 11 7/8"

802



Portagioie/Portapasticcini  
Jewel case/Petit fours case  
Porte bijoux/Porte petit patisserie  
Schmuckablage/Bonbonträger  
Joyero/Porta dulces

cm. 15 x 15 | 6" x 6"

# BUFFET



**L7** Lime  
Lime  
Lime  
Limone  
Lima

**O** Arancio  
Orange  
Orange  
Orange  
Naranja

**V7** Viola  
Violet  
Violet  
Pflaume  
Violeta

**N** Nero  
Black  
Noir  
Schwarz  
Negro

**W** Bianco  
White  
Blanc  
Weiss  
Blanco

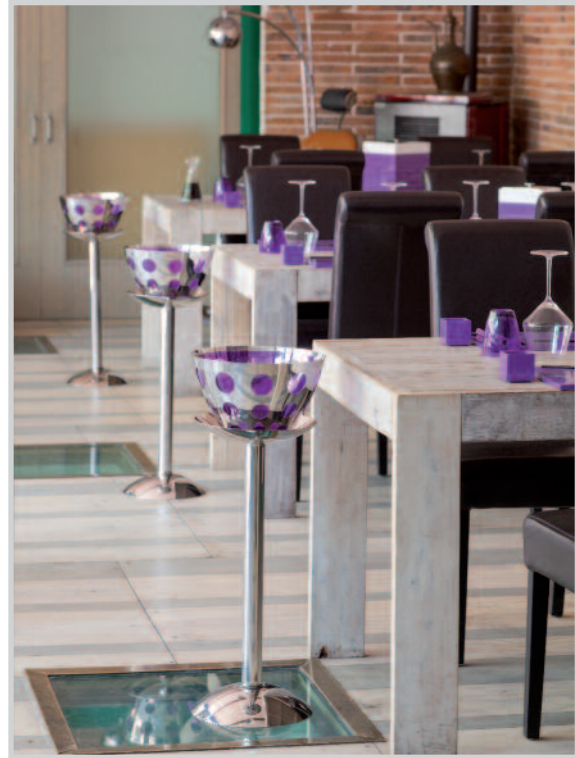









549



mm. 1,2 | Centrotavola  
Tray 14 compartments  
Plateau 14 pièces  
Tablett 14 Einsatze  
Bandeja 14 posiciones

cm. 45 x 28 | 17<sup>3</sup>/<sub>4</sub>" x 11<sup>1</sup>/<sub>8</sub>"

537

53706

53712



mm. 1,2 | Mini vassoi per finger food  
Mini trays for finger food  
Mini plateau pour finger food  
Mini Tablett für finger food  
Mini bandejas por finger food

cm. 12 x 12 | 4<sup>3</sup>/<sub>4</sub>" x 4<sup>3</sup>/<sub>4</sub>"  
cm. 15 x 15 | 5<sup>7</sup>/<sub>8</sub>" x 5<sup>7</sup>/<sub>8</sub>"

7011

7011E

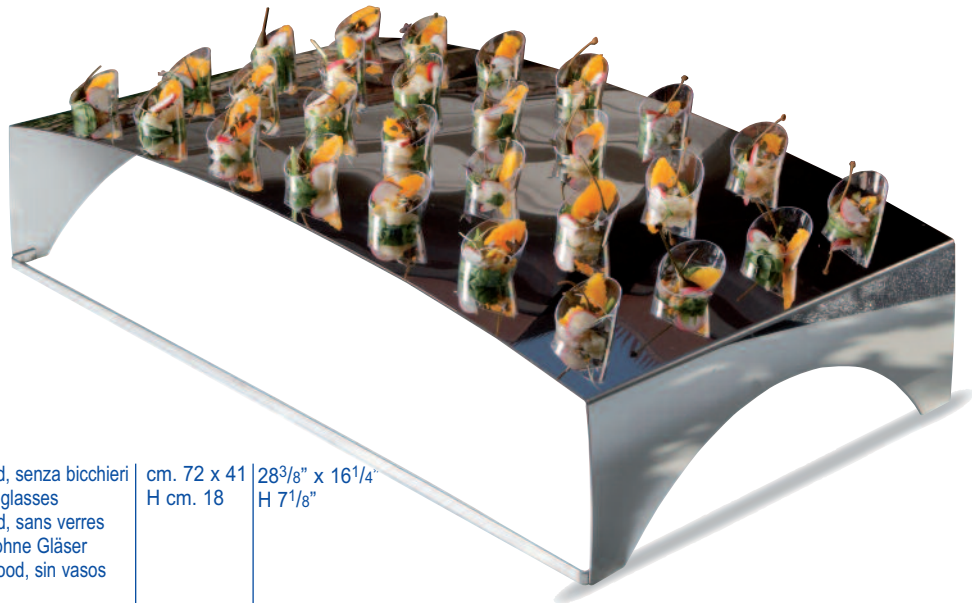

mm. 1,2 | Espositore buffet per finger food, senza bicchieri  
Buffet set for finger food, w/out glasses  
Service à buffet pour finger food, sans verres  
Buffet Display für Finger food, ohne Gläser  
Servicio para buffet por finger food, sin vasos

cm. 72 x 41 | 28<sup>3</sup>/<sub>8</sub>" x 16<sup>1</sup>/<sub>4</sub>"  
H cm. 18 | H 7<sup>1</sup>/<sub>8</sub>"

563



mm. 1,2 | Quadro piano  
Square tray  
Plateau carré  
Tablett, quadratisch  
Bandeja cuadrada

cm. 15 x 15 | 5<sup>7</sup>/<sub>8</sub>" x 5<sup>7</sup>/<sub>8</sub>"  
cm. 22 x 22 | 8<sup>5</sup>/<sub>8</sub>" x 8<sup>5</sup>/<sub>8</sub>"

560



mm. 1,2 | Tondo fondo  
Round bowl  
Bol ronde  
Obstschale, rund  
Cuenco redondo

Ø cm. 12 cl. 26 | Ø 4<sup>3</sup>/<sub>4</sub>" oz. 8<sup>3</sup>/<sub>4</sub>  
Ø cm. 15 cl. 60 | Ø 5<sup>7</sup>/<sub>8</sub>" oz. 20<sup>1</sup>/<sub>4</sub>  
Ø cm. 22 cl. 131 | Ø 8<sup>5</sup>/<sub>8</sub>" oz. 44<sup>1</sup>/<sub>3</sub>  
Ø cm. 32 lt. 3,0 | Ø 12<sup>5</sup>/<sub>8</sub>" oz. 101<sup>2</sup>/<sub>5</sub>







# BUFFET





591P



Bicchiere  
Glass  
Gobelet  
Glas  
Vaso

H cm 13	H 5"
cl. 45	oz 15 1/4

588P



Bicchiere  
Glass  
Gobelet  
Glas  
Vaso

H cm 10	H 3 7/8"
cl. 33	oz. 11 1/8

1131

10521131



10521108

Mini Forchetta Appetizer fork Fourchette amouse bouche Minigabel Mini tenedor	cm. 11,4	4 1/2"	Mini spoon	cm. 11,4	4 1/2"
--	----------	--------	------------	----------	--------

7012



Vassoio per canapé con bicchieri Canape tray with glasses Plateau à canape avec verres Buffet Display mit Gläser Bandeja para canapé con vasos	8 pz. cm. 42 x 42	8 pcs 16 1/2" x 16 1/2"
	17 pz. cm. 42 x 72,5	17 pcs 16 1/2" x 28 1/2"

543N



Bicchiere per champagne  
Champagne glass  
Verre pour Champagne  
Champagnerglas  
Vaso por champán

H cm. 22,7	H 9"
cl. 15	oz. 5 1/8

555N

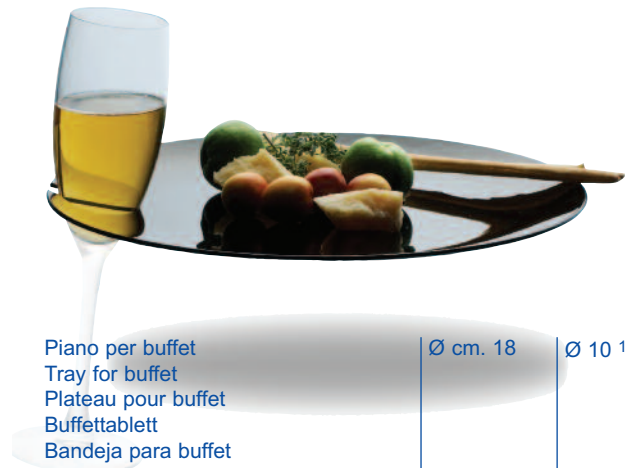

Piano per buffet  
Tray for buffet  
Plateau pour buffet  
Buffettablett  
Bandeja para buffet

Ø cm. 18	Ø 10 1/2"
----------	-----------

543

**A** Ambra  
Amber  
Ambre  
Amber  
Ambar



**G** Granato  
Garnet  
Grenat  
Granat  
Granate



**Q** Quarzo  
Quartz  
Quartz  
Quarz  
Cuarzo



**S** Smeraldo  
Emerald  
Emeraude  
Smaragd  
Esmeralda



**V** Olivina  
Olivine  
Olivine  
Olivia  
Olivino



**Z** Zaffiro  
Sapphire  
Saphir  
Saphir  
Zafiro



**M** Ametista  
Amethyst  
Amethyste  
Amethyst  
Amatista



**W** Trasparente  
Transparent  
Glace  
Transparent  
Vidrio



**O** Onice  
Onyx  
Onyx  
Onyx  
Onice



**P** Porcellana  
White  
Porcelain  
Weiss  
Porcelana



**N** Nero  
Black  
Noir  
Schwarz  
Negro







682



TU0687G

mm. 0,8 | Caraffa per bibite  
Jug for drinks w/ice container  
Carafe avec compartiment glaçons  
Saftkrug mit Kühleinsatz  
Jarra agua | lt. 2,5 | 84 1/2 oz.

691



TU0692V

mm. 0,8 | Infusiera con contenitore trasparente  
Infuser jug  
Carafe d'eau avec infuseur  
Wasserkrug mit Infuser  
Jarra de agua de infusión | lt. 2,5 | 84 1/2 oz.

68702



TU0687G

mm. 0,8 | AURORA  
Caraffa per bibite  
Jug for drinks w/ice container  
Carafe avec compartiment glaçons  
Saftkrug mit Kühleinsatz  
Jarra agua | lt. 2 | 67 3/4 oz.

69202



TU0692V

mm. 0,8 | AURORA  
Infusiera con contenitore trasparente  
Infuser jug  
Carafe d'eau avec infuseur  
Wasserkrug mit Infuser  
Jarra de agua de infusión | lt. 2 | 67 3/4 oz.

68703



TU0687G

mm. 0,8 | AURORA  
Caraffa per bibite  
Jug for drinks w/ice container  
Carafe avec compartiment glaçons  
Saftkrug mit Kühleinsatz  
Jarra agua | lt. 3 | 101 1/2 oz.

69203



TU0692V

mm. 0,8 | AURORA  
Infusiera con contenitore trasparente  
Infuser jug  
Carafe d'eau avec infuseur  
Wasserkrug mit Infuser  
Jarra de agua de infusión | lt. 3 | 101 1/2 oz.



7199



PALACE  
Chafing Dish rettangolare con coperchio girevole a 180°  
Rectangular Chafing Dish with 180° revolving cover  
Chafing Dish rectangulaire avec couvercle basculant à 180°  
Chafing Dish rechteckig mit 180° Rollhaube  
Chafing Dish rectangular con tapa volvible à 180°

cm. 66 x 45  
H cm. 43  
Lt. 6,5  
26" x 17 3/4"  
H 17"  
gal. 1 3/4

7199A



cm. 52 x 32  
20 1/2" x 12 3/4"

PALACE  
Zuppiera per art. 7199  
Soup station for art. 7199  
Marmite à potage pour art. 7199  
Suppenstation für Art. 7199  
Sopera para art. 7199

Ø cm. 21,5 | Ø 8 1/2"

7201



PALACE  
Chafing Dish tondo con coperchio girevole a 180°  
Round Chafing Dish with 180° revolving cover  
Chafing Dish rond avec couvercle basculant à 180°  
Chafing Dish rund mit 180° Rollhaube  
Chafing Dish rendono con tapa volvible à 180°

Ø cm. 40  
H cm. 46  
Lt. 4,5  
Ø 15 3/4"  
H 18 1/8"  
gal. 1 1/4

7201A

Ø cm. 38,5 esterno  
Ø cm. 22 interno

Ø 15 1/8" outside  
Ø 8 3/4" inside

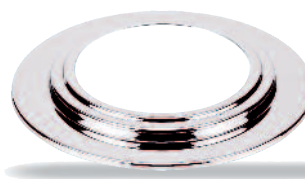

PALACE  
Zuppiera per art. 7201  
Soup station for art. 7201  
Marmite à potage pour art. 7201  
Suppenstation für Art. 7201  
Sopera para art. 7201

Ø cm. 21,5 | Ø 8 1/2"

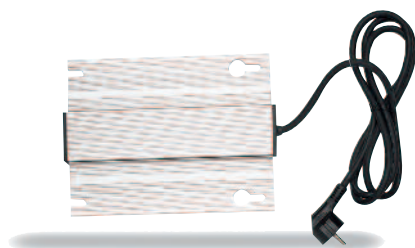

Piastra elettrica per art. 7199  
Electric Heater for art. 7199  
Element de chauffage électrique pour art. 7199  
Heizelement für Art. 7199  
Calientador eléctrico para art. 7199

7199B 110V  
7199C 220V  
cm. 25 x 19  
9 3/4" x 7 1/2"

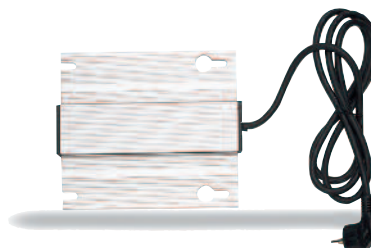

Piastra elettrica per art. 7201  
Electric Heater for art. 7201  
Element de chauffage électrique pour art. 7201  
Heizelement für Art. 7201  
Calientador eléctrico para art. 7201

7201B 110V  
7201C 220V  
cm. 21,5 x 18,5  
8 1/2" x 7 1/4"

151



mm. 1,2 | Vassoio rettangolare  
Rectangular tray  
Plateau de presentation  
Tablett, rechteckig  
Bandeja rectangular

cm. 63 x 45  
24 11/16" x 17 3/4"

7204



Coffee Urn	PALACE	Ø cm. 32	gal. 2 <sup>3</sup> / <sub>4</sub>
Coffee Urn	"	H cm. 60	H 23 <sup>5</sup> / <sub>8</sub> "
Bouilleur	"	lt. 11	Ø 12 <sup>5</sup> / <sub>8</sub> "
Kaffeespender	"	Ø cm. 32	Ø 12 <sup>5</sup> / <sub>8</sub> "
Contenedor para café	"	H cm. 67	H 26 <sup>3</sup> / <sub>8</sub> "
		lt. 19	gal. 5

7206



Distributore per succo di frutta	PALACE	cm. 26 x 35	10 1/4" x 13 3/4"
Juice dispenser	"	H cm. 58	H 22 7/8"
Distributeur à jus	"	lt. 7	gal. 1 7/8
Saftdispenser	"		
Contenedor para zumo de fruta	"		

7208



Doppio distributore per succo di frutta	PALACE	cm. 56 x 35
Double Juice dispenser	"	H cm. 58
Double distributeur à jus	"	lt. 14
Doppel Saftdispenser	"	22" x 13 3/4"
Doble contenedor para zumo de fruta	"	H 22 7/8"
		gal. 3 1/2

HAPPY

10001175

10001123



10001122



10001111



10001110



10001142



10001116



Ø mm.10



Nuovo sistema per il servizio delle pietanze, per evitare la caduta delle posate all'interno degli chafing. Tutta la collezione HAPPY è a pag. 69.

A new collection of serving pieces designed with a handle that securely rests on the edge of the chafing dish when not in use. The entire Happy collection can be found on page 69.

Nouveau système pour le service des plats, pour éviter la chute des couverts à l'intérieur des chafing. Toute la collection HAPPY est au pag. 69.

"HAPPY" ist eine neue platzsparende Idee, wie man von Chafing Dishes Speisen auf Teller füllen kann, ohne dass die Servierteile hineinfallen. Gesamte HAPPY Kollektion auf Seite 69.

Nuevo sistema por el servicio de las comidas, para evitar la caída de los cubiertos dentro de los chafing. Toda la colección HAPPY es a pag. 69.

Appoggia posate  
Knife rest  
Soutier p/couverts  
Messer bank  
Apoyo p/cubiertos

Largh. cm 6,5  
Width 2 1/2"



7088



GALA  
Chafing Dish 1/1 rettangolare con coperchio girevole a 180°  
Rectangular Chafing Dish 1/1 with 180° revolving cover  
Chafing Dish 1/1 rectangulaire avec couvercle basculant à 180°  
Chafing Dish 1/1 rechteckig mit 180° Rollhaube  
Chafing Dish 1/1 rectangular con tapa volvible à 180°

cm. 64 x 32  
H cm. 43,5  
lt. 6,5  
25 1/4" x 12 5/8"  
H 17 1/8"  
gal. 1 3/4

7089



GALA  
Chafing Dish tondo con coperchio girevole a 180°  
Round Chafing Dish with 180° revolving cover  
Chafing Dish rond avec couvercle basculant à 180°  
Chafing Dish rund mit 180° Rollhaube  
Chafing Dish rondondo con tapa volvible à 180°

Ø esterno cm. 40  
Ø interno cm. 30  
lt. 4,5  
Ø inside 11 3/4"  
Ø outside 15 3/4"  
gal. 1 1/4

7088A

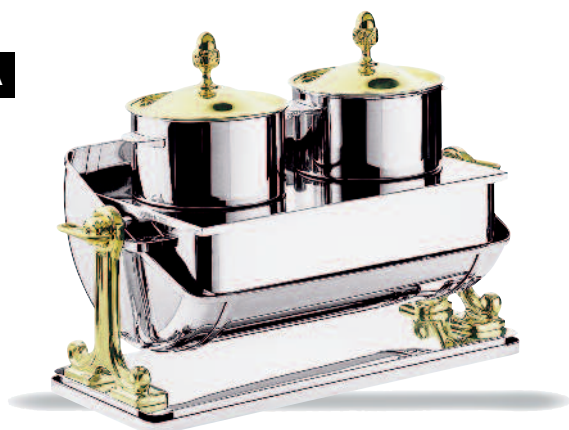

Zuppiera per art.	7088	cm. 64 x 32	25 1/4" x 12 5/8"
Soup tureen for art.	"	H cm. 43,5	H 17 1/8"
Marmite à potage pour art.	"	lt. 6,5	gal. 1 3/4
Suppenstation für art.	"		
Sopera para art.	"		

7089A



Zuppiera per art.	7089	Ø esterno cm. 40
Soup tureen for art.	"	Ø interno cm. 30
Marmite à potage pour art.	"	lt. 4,5
Suppenstation für art.	"	Ø inside 11 3/4"
Sopera para art.	"	Ø outside 15 3/4"
		gal. 1 1/4

7087



Chafing Dish 1/1 rettangolare con coperchio amovibile	cm. 61 x 30	24" x 11 3/4"
Rectangular Chafing Dish 1/1 with removable cover	H cm. 32,5	H 12 3/4"
Chafing Dish 1/1 rectangulaire avec couvercle démontable	lt. 6,5	gal. 1 3/4
Chafing Dish 1/1 rechteckig mit abnehmbarer Haube		
Chafing Dish 1/1 rectangular con tapa amovible		

7086



GIOTTO	cm. 61 x 30
Chafing Dish 1/1 rettangolare con coperchio amovibile	H cm. 32,5
Rectangular Chafing Dish 1/1 with removable cover	lt. 6,5
Chafing Dish 1/1 rectangulaire avec couvercle démontable	24" x 11 3/4"
Chafing Dish 1/1 rechteckig mit abnehmbarer Haube	H 12 3/4"
Chafing Dish 1/1 rectangular con tapa amovible	gal. 1 3/4

7090



mm. 0,8	Rinfrescatore per yogurt Yogurt cooler Rafrachisseur à yaourts Yoghurtkühler Refrigerador para yogurt	cm. 52,5 x 32,5 lt. 8	20 <sup>5</sup> / <sub>8</sub> " x 12 <sup>3</sup> / <sub>4</sub> " gal. 2
---------	---	--------------------------	---

7999



Culla portachampagne Champagne holder Porte-champagne Champagnerflaschenhalter Portabotella de champagne	"MATHUSALEM" lt. 6 - gal. 1 1/2 "SALMANAZAR" lt. 9 - gal. 2 1/2 cm 45 x 31 - H cm 65 17 3/4" x 12 1/4" - H 25 1/2"
--	---

236

NEW



mm. 1,2	Rinfrescatore per yogurt Yogurt cooler Rafrachisseur à yaourts Yoghurtkühler Refrigerador para yogurt	Ø cm.38 H cm. 9 lt. 3,0	Ø 15" H 3 1/2" oz. 101 2/5
---------	---	-------------------------------	----------------------------------

7092



7092

Candelabro a 1 fiamma Candlestick Chandelier Leuchter 1-flammig Candelabro	Silverplated H cm. 28,5 H 11 1/4"
--	---



7093

Candelabro a 3 fiamme Candelabra, 3 arms Chandelier 3 flammes Leuchter 3-flammig Candelabro 3 luces	Silverplated H cm. 34,5 H 13 5/8"
---	---



7094

Candelabro a 5 fiamme Candelabra, 5 arms Chandelier 5 flammes Leuchter 5-flammig Candelabro 5 luces	Silverplated H cm. 34,5 H 13 5/8"
---	---

7094





641



mm. 1,2	Caffetteria	BOMBATA	Tazze	1	cl. 15	5 1/8 oz.
	Coffee pot	»	Cups	2	cl. 27	9 1/8 oz.
	Cafetière	»	Bols	4	cl. 37	12 1/2 oz.
	Kaffeekanne	»	Tassen	6	cl. 55	18 5/8 oz.
	Cafetera	»	Tazas	8	cl. 85	28 3/4 oz.
				10	cl. 110	37 1/4 oz.
				12	cl. 150	50 3/4 oz.
				16	cl. 200	67 5/8 oz.

642



mm. 1,2	Teiera	BOMBATA	Tazze	1	cl. 20	6 3/4 oz.
	Tea pot	»	Cups	2	cl. 35	11 7/8 oz.
	Théière	»	Bols	4	cl. 50	16 7/8 oz.
	Teekanne	»	Tassen	6	cl. 70	23 5/8 oz.
	Tetera	»	Tazas	8	cl. 95	32 1/8 oz.
				10	cl. 120	40 5/8 oz.

643



mm. 1,2	Lattiera	BOMBATA	Tazze	1/2	cl. 10	3 3/8 oz.
	Milk jug	»	Cups	1	cl. 15	5 1/8 oz.
	Pot à lait	»	Bols	2	cl. 27	9 1/8 oz.
	Milchkanne	»	Tassen	4	cl. 37	12 1/2 oz.
	Jarra lechera	»	Tazas	6	cl. 55	18 5/8 oz.
				8	cl. 85	28 3/4 oz.
				10	cl. 110	37 1/4 oz.
				12	cl. 150	50 3/4 oz.
			16	cl. 200	67 5/8 oz.	

644



644P

mm. 1,2	Zuccheriera	BOMBATA	Tazze	2	cl. 15	5 1/8 oz.
	Sugar bowl	»	Cups	4	cl. 20	6 3/4 oz.
	Sucrier	»	Bols	6	cl. 27	9 1/8 oz.
	Zuckerdose	»	Tassen	8	cl. 35	11 7/8 oz.
	Azucarero	»	Tazas			

647



mm. 1,2	Caraffa termica per acqua c/fermaghiaccio	BOMBATA		cl. 150
	Insulated water pitcher w/ice-trap	»		
	Carafe à eau avec attrape-glace	»		
	Isolier-Wasserkrug	»		50 3/4 oz.
	Jarra agua c/tope	»		

645



mm. 1,2	Caffetteria termica	BOMBATA	Tazze	4	cl. 30	10 1/8 oz.
	Insulated coffee pot	»	Cups	6	cl. 60	20 1/4 oz.
	Cafetière thermique	»	Bols	12	cl. 150	50 3/4 oz.
	Isolier-Kaffeekanne	»	Tassen			
	Cafetera térmica	»	Tazas			



621



mm. 1,2	Caffetteria con piedistallo BOMBATA	Tazze	1	cl. 15	5 1/8 oz.
	Coffee pot with base »	Cups	2	cl. 27	9 1/8 oz.
	Cafetière avec socle »	Bols	4	cl. 37	12 1/2 oz.
	Kaffeekanne auf Fuss »	Tassen	6	cl. 55	18 5/8 oz.
	Cafetera con pedestal »	Tazas	8	cl. 85	28 3/4 oz.
			10	cl. 110	37 1/4 oz.
			12	cl. 150	50 3/4 oz.
		16	cl. 200	67 5/8 oz.	

622



mm. 1,2	Teiera con piedistallo BOMBATA	Tazze	2	cl. 35	11 7/8 oz.
	Tea pot with base »	Cups	4	cl. 50	16 7/8 oz.
	Théière avec socle »	Bols	6	cl. 70	23 5/8 oz.
	Teekanne auf Fuss »	Tassen	8	cl. 95	32 1/8 oz.
	Tetera con pedestal »	Tazas	10	cl. 120	40 7/8 oz.

623



mm. 1,2	Lattiera con piedistallo BOMBATA	Tazze	1	cl. 15	5 1/8 oz.
	Milk jug with base »	Cups	2	cl. 27	9 1/8 oz.
	Pot à lait avec socle »	Bols	4	cl. 37	12 1/2 oz.
	Milchkanne auf Fuss »	Tassen	6	cl. 55	18 5/8 oz.
	Jarra lechera con pedestal »	Tazas	8	cl. 85	28 3/4 oz.
			10	cl. 110	37 1/4 oz.
			12	cl. 150	50 3/4 oz.
		16	cl. 200	67 5/8 oz.	

624



624P

mm. 1,2	Zuccheriera con piedistallo BOMBATA	Tazze	2	cl. 15	5 1/8 oz.
	Sugar bowl with base »	Cups	4	cl. 20	6 3/4 oz.
	Sucrier avec socle »	Bols	6	cl. 27	9 1/8 oz.
	Zuckerdose auf Fuss »	Tassen	8	cl. 35	11 7/8 oz.
	Azucarero con pedestal »	Tazas			

646



mm. 1,2	Caffetteria termica con piedistallo BOMBATA	Tazze	4	cl. 30	10 1/8 oz.
	Insulated coffee pot with base »	Cups	6	cl. 60	20 1/4 oz.
	Cafetière thermique avec socle »	Bols	12	cl. 150	50 3/4 oz.
	Isolier-Kaffeekanne auf Fuß »	Tassen			
	Cafetera térmica con pedestal »	Tazas			

648



mm. 1,2	Caraffa termica c/fermaghiaccio e piedistallo BOMBATA			cl. 150	
	Insulated water pitcher w/ice-trap and base »				
	Carafe à eau avec attrape-glace et socle »				
	Isolier-Wasserkrug auf Fuss »				50 3/4 oz.
	Jarra agua c/tope y pedestal »				

940



mm. 1,2	Servizio per caffè macchiato Café au lait set Service pour café au lait Café au Lait-Set Juego café au lait	H cm 18 cl. 102	H 7 <sup>1</sup> / <sub>8</sub> " oz. 34
---------	---	--------------------	---

940/5



mm. 1,2	Servizio per caffè macchiato 5pcs Sugar, milk and coffee set Service sucre, lait et café 5 pièces Milch - Kaffee - Zucker Set 5-Tlg. Juego leche, café y azúcar 5 piezas	cl. 15 (x5)	oz. 5 <sup>1</sup> / <sub>8</sub> (x5)
---------	--	-------------	--

940/3



mm. 1,2	Servizio per zucchero 3 pezzi Sugar set 3 pcs. Service pour sucre 3 pièces Zucker Menage 3-Tlg Juego azúcar 3 piezas	cl. 15 (x3)	oz. 5 <sup>1</sup> / <sub>8</sub> (x3)
---------	--	-------------	--

940/4



mm. 1,2	Servizio per zucchero 4 pezzi Sugar set 4 pcs. Service pour sucre 4 pièces Sahne-/Zucker-Set 4-Tlg Juego azúcar 4 piezas	cl. 15 (x4)	oz. 5 <sup>1</sup> / <sub>8</sub> (x4)
---------	--	-------------	--

649



mm. 1,2	Bricco Jug Cruche Milchkännchen Jarra	BOMBATA	cl. 20	oz. 6 <sup>3</sup> / <sub>4</sub>
---------	---	---------	--------	-----------------------------------

771



mm. 0,8	Molla per zucchero Sugar tongs Pince à sucre Zuckerzange Pinzas azúcar	Lungh. cm. 14	Length 5 <sup>1</sup> / <sub>2</sub> "
---------	--	---------------	--





361



mm. 1,2	Caffetteria	IMMAGINA	Tazze	1	cl. 10	3 3/8 oz.
	Coffee pot	»	Cups	4	cl. 34	11 1/2 oz.
	Cafetière	»	Bols	6	cl. 50	16 7/8 oz.
	Kaffeekanne	»	Tassen	8	cl. 75	25 3/8 oz.
	Cafetera	»	Tazas	10	cl. 97	32 4/5 oz.
				16	cl. 200	67 5/8 oz.

362



mm. 1,2	Teiera	IMMAGINA	Tazze	2	cl. 35	11 7/8 oz.
	Tea pot	»	Cups	4	cl. 50	16 7/8 oz.
	Théière	»	Bols	6	cl. 75	25 3/8 oz.
	Teekanne	»	Tassen	8	cl. 97	32 4/5 oz.
	Tetera	»	Tazas			

363



mm. 1,2	Lattiera	IMMAGINA	Tazze	1	cl. 10	3 3/8 oz.
	Milk jug	»	Cups	4	cl. 34	11 1/2 oz.
	Pot à lait	»	Bols	6	cl. 52	17 5/8 oz.
	Milchkanne	»	Tassen	8	cl. 75	25 3/8 oz.
	Jarra lechera	»	Tazas	16	cl. 200	67 5/8 oz.

364



mm. 1,2	Zuccheriera porta bustine	IMMAGINA	364A			
	Sugar packets holder	»	364A	cl. 20	6 3/4 oz.	
	Sucrier à sachets	»	364A			
	Zuckerdose/Zuckerstangengefäß	»	364A	cl. 22	7 1/2 oz.	
	Azucarera	»	364B			
			364B	cl. 10	3 3/8 oz.	

366

NEW



mm. 1,2	Caffetteria termica	IMMAGINA	Tazze	6	cl. 50	
	Insulated coffee pot	»	Cups	8	cl. 75	
	Cafetière thermique	»	Bols			
	Isolier-Kaffeekanne	»	Tassen		16 7/8 oz.	
	Cafetera térmica	»	Tazas		25 3/8 oz.	

NEW



mm. 1,2	Teiera termica	IMMAGINA	Tazze	4	cl. 50	
	Insulated tea pot	»	Cups	6	cl. 75	
	Théière thermique	»	Bols			
	Isolier-Teekanne	»	Tassen		16 7/8 oz.	
	Tetera térmica	»	Tazas		25 3/8 oz.	

367



631



mm. 1,2	Caffetteria	PARTY	Tazze	2	cl. 24	8 1/8 oz.
	Coffee pot	»	Cups	4	cl. 34	11 1/2 oz.
	Cafetière	»	Bols	6	cl. 46	15 1/2 oz.
	Kaffeekanne	»	Tassen	8	cl. 63	21 1/8 oz.
	Cafetera	»	Tazas	10	cl. 100	33 7/8 oz.
				12	cl. 150	50 3/4 oz.
				16	cl. 200	67 5/8 oz.

632



mm. 1,2	Teiera	PARTY	Tazze	2	cl. 40	13 1/2 oz.
	Tea pot	»	Cups	4	cl. 50	16 7/8 oz.
	Théière	»	Bols	6	cl. 68	23 oz.
	Teekanne	»	Tassen	8	cl. 90	30 1/2 oz.
	Tetera	»	Tazas			

633



mm. 1,2	Lattiera	PARTY	Tazze	1	cl. 10	3 3/8 oz.
	Milk jug	»	Cups	2	cl. 24	8 1/8 oz.
	Pot à lait	»	Bols	4	cl. 34	11 1/2 oz.
	Milchkanne	»	Tassen	6	cl. 46	15 1/2 oz.
	Jarra lechera	»	Tazas	8	cl. 63	21 1/4 oz.
				10	cl. 100	33 7/8 oz.
				12	cl. 150	50 3/4 oz.
			16	cl. 200	67 5/8 oz.	

634



mm. 1,2	Zuccheriera	PARTY	Tazze	4	cl. 15	5 1/8 oz.
	Sugar bowl	»	Cups	6	cl. 22	7 1/2 oz.
	Sucrier	»	Bols	8	cl. 28	9 1/2 oz.
	Zuckerdose	»	Tassen			
	Azucarero	»	Tazas			

635



mm. 1,2	Brocca per acqua con fermaggiaccio	PARTY	cl. 100
	Water pitcher with ice-trap	»	cl. 200
	Carafe à eau avec attrape-glace	»	
	Eiswaserkrug	»	33 4/5 oz.
	Jarra agua c/tope	»	67 2/3 oz.

651



mm. 1,2	Caffetteria	LADY	Tazze	2	cl. 25	8 1/2 oz.
	Coffee pot	»	Cups	4	cl. 37	12 1/2 oz.
	Cafetière	»	Bols	6	cl. 52	17 5/8 oz.
	Kaffeekanne	»	Tassen	8	cl. 70	23 5/8 oz.
	Cafetera	»	Tazas	10	cl. 100	33 7/8 oz.
				12	cl. 150	50 3/4 oz.
				16	cl. 200	67 5/8 oz.

652



mm. 1,2	Teiera	LADY	Tazze	2	cl. 40	13 1/2 oz.
	Tea pot	»	Cups	4	cl. 55	18 5/8 oz.
	Théière	»	Bols	6	cl. 70	23 5/8 oz.
	Teekanne	»	Tassen	8	cl. 97	32 3/4 oz.
	Tetera	»	Tazas			

653



mm. 1,2	Lattiera	LADY	Tazze	1	cl. 10	3 3/8 oz.
	Milk jug	»	Cups	2	cl. 25	8 1/2 oz.
	Pot à lait	»	Bols	4	cl. 37	12 1/2 oz.
	Milchkanne	»	Tassen	6	cl. 52	17 5/8 oz.
	Jarra lechera	»	Tazas	8	cl. 70	23 5/8 oz.
				10	cl. 100	33 7/8 oz.
				12	cl. 150	50 3/4 oz.
			16	cl. 200	67 5/8 oz.	

654



mm. 1,2	Zuccheriera	LADY	Tazze	2	cl. 13	4 3/8 oz.
	Sugar bowl	»	Cups	4	cl. 18	6 1/8 oz.
	Sucrier	»	Bols	6	cl. 22	7 1/2 oz.
	Zuckerdose	»	Tassen	8	cl. 30	10 1/8 oz.
	Azucarero	»	Tazas			



516



mm. 1,2	Portabustine da zucchero Sugar packet holder Pot à sucre Zuckerstangengefäß Azucarera	cm. 10 x 7 H cm. 3	4" x 2 3/4" H 1 1/8"
---------	---	-----------------------	-------------------------

206

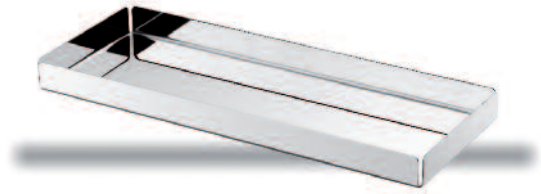

mm. 1,2	Vassoio per pasticceria Patisserie tray Plateau pour patisserie Patisserie Tablett Bandeja para pasteleria	cm. 26 x 12 cm. 60 x 12	10 1/4" x 4 3/4" 23 3/5" x 10 1/5"
---------	--	----------------------------	---------------------------------------

136



mm. 1,2	Vassoio Tray Plateau Kaffeetablett Bandeja	CAFE' VIENNA » » » »	cm. 26 x 22	10 1/4" x 8 2/3"
---------	--	----------------------------------	-------------	------------------

704

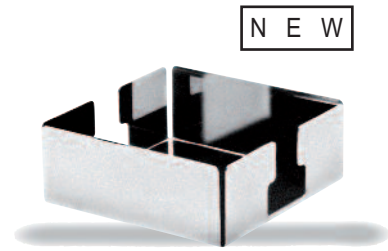

mm. 1,2	Portatovaglioli Napkin holder Distributeur de serviettes Serviettenhalter Portaservilletas	cm. 13 x 13	5 1/9" x 5 1/9"
---------	--	-------------	-----------------

902



mm. 1,2	Portabastoncini da zucchero Sugar bags holder Pot à sucre Zuckerstangengefäß Azucarera	Ø cm 7 H cm 8	H 3 1/4" Ø 2 3/4"
---------	--	------------------	----------------------

700



mm. 1,2	Zuccheriera Sugar container Sucriere Zuckerdose Azucarero	Ø cm 10 cl.35	Ø 4" oz 11 7/8
---------	---	------------------	-------------------

594



mm. 1,2	Cremiera con piedistallo UNO Cream jug with base » Cremiér avec socle » Sahnegießer/Milchkännchen » Jarrita lechera con pedestal »	cl.16	oz. 5 <sup>3</sup> / <sub>8</sub>
---------	--	-------	-----------------------------------

595



mm. 1,2	Zuccheriera con piedistallo UNO Sugar bowl with base » Sucrier avec socle » Zuckerdose auf Fuss » Azucarero con pedestal »	cl. 24	oz. 8 <sup>1</sup> / <sub>8</sub>
---------	--	--------	-----------------------------------

499



mm. 1,2	MINIMA Portabustine da zucchero 4 sc. Sugar packets holder 4 compt. Pot à sucre 4 comp. Zuckerstangengefäß 4 Eins. Azucarera 4 comp.	cm.15 x 11 H.cm.14	5 <sup>7</sup> / <sub>8</sub> " x 4 <sup>3</sup> / <sub>8</sub> " H. 5 <sup>1</sup> / <sub>2</sub> "
---------	---	-----------------------	---

706



mm. 1,2	Porta salviette lavamani Tray for hand towels Plateau porte serviettes Tablett für Stoffservietten Bandeja portaservilletas	cm. 15 x 9	5 <sup>7</sup> / <sub>8</sub> " x 3 <sup>1</sup> / <sub>2</sub> "
---------	---	------------	---

703



mm.1,2	Set per latte macchiato Latte Macchiato Set Service pour Latte Macchiato Latte Macchiato-Set Servicio para café con leche	Ø cm. 10 cl. 36	Ø 3 <sup>7</sup> / <sub>8</sub> " oz. 12 <sup>3</sup> / <sub>8</sub>
--------	---	--------------------	---

10201144



mm. 3,0	Cucchiaino cappuccino Cappuccino spoon Cuillère cappuccino Cappuccinolöffel Cucharita cappuccino	Lungh. cm. 16,5	Length 6 <sup>1</sup> / <sub>2</sub> "
---------	--	-----------------	--





803C

**Coffee Design Kit**

Cucchiaino caffè, bicchiere in vetro, piattino in ardesia.

Teaspoon, transparent cup, natural stone slate coaster.

Cuillère, tasse transparente, sous tasse en ardoise naturelle.

Kaffeelöffel, Becher auf Glass, Untersatz in Schiefer Naturstein.

Cucharita, taza transparente, posavasos en elegante pizarra piedra natural.



Coffee Design Kit è un rivoluzionario kit che ci permette di stupire i nostri ospiti con un nuovo concetto di dessert gustosi ed originali, di grande effetto, ma facili e veloci da preparare.

Coffee Design Kit si compone di 1 inedito bicchierino trasparente modellato a fasce orizzontali, per facilitare le dosi dei vari strati, 1 cucchiaino in acciaio 18/10 finitura satinata, progettato appositamente per facilitare la stratificazione degli ingredienti, 1 elegante sottobicchiere in pietra naturale di ardesia.

Coffee Design Kit is a revolutionary kit that allows us to surprise our guests with a new concept of tasty and original desserts, highly impressive, yet easy and quick to prepare. Coffee Design Kit is made of an unique transparent cup shaped with horizontal bands to facilitate the doses of the various layers, a teaspoon in 18/10 stainless steel in brushed finishing specifically designed to facilitate the layering of the ingredients, a coaster in elegant natural stone slate.

Coffee Design Kit est un kit révolutionnaire qui nous permet d'émerveiller nos hôtes avec un nouveau concept de desserts originaux et savoureux, de grand effet, mais faciles et rapides à préparer.

Coffee Design Kit est composé de une tasse transparente uniques avec des lignes horizontales afin de faciliter les doses des différentes couches, de un cuillère en acier 18/10 en finition satinée spécialement conçues pour faciliter la superposition des ingrédients, une élégante sous tasse en ardoise naturelle.

Das Coffee-Design-Kit ist ein revolutionäres Set, das es uns ermöglicht, unsere Gäste mit einem neuen Konzept von leckeren und originellen Desserts zu überraschen, sehr beeindruckend, und dennoch einfach und schnell zuzubereiten.

Das Coffee Design Kit besteht aus 1 einzigartigen, transparenten Becher, jeweils mit horizontalen Streifen versehen, um die Mengenbestimmung der verschiedenen Schichten zu erleichtern, 1 Kaffeelöffel aus Edelstahl 18/10 in mattem Finish, die speziell abgestimmt sind auf das Konzept, 1 Untersatz in eleganten Schiefer Naturstein

Coffee Design Kit es un kit revolucionario que permite sorprender a nuestros invitados con un nuevo concepto de postres sabrosos y originales, muy impresionantes, pero fáciles y rápidos de preparar.

Coffee Design Kit consiste en 1 taza transparente de forma única con bandas horizontales, para facilitar las dosis de varias capas, 1 cucharita en acero inoxidable de 18/10 en acabado satinado, diseñadas específicamente para facilitar la estratificación de los ingredientes, 1 posavasos en elegante pizarra piedra natural.





941

661

665



Portacucchiai per bar  
Coffee spoons stand  
Pot à cuillères pour bar  
Löffelbecher  
Porta-cucharitas para bar  
mm. 0,8

Ø cm. 9 | Ø 3 1/4"

Secchiello per spumante  
Sparkling wine cooler  
Seau à champagne  
Wein-und Sektkühler  
Cubo para champany  
mm. 1,2

Ø cm. 18 | Ø 7 1/4"  
H cm. 18,5 | H 7 1/8"  
lt. 4 | gal. 1

Secchiello per ghiaccio  
Ice-bucket with knobs  
Seau à glaçons  
Eisgefäß  
Cubitera hielo  
mm. 0,8

Ø cm. 13,5 | Ø 5 3/8"  
H cm. 13 | H 5 1/8"  
cl. 150 | oz. 50 3/4

708



mm. 1,2

Piattino portamonete  
Cash tray  
Plat à addition  
Zahlteller  
Bandeja porta monedas

cm. 11 x 15 | 4 3/8" x 5 7/8"

545



548

545  
546  
547

mm. 1,2

Dosatore  
Jigger  
Doseur  
Barmaß  
Medida

cl. 2 e 4 | oz. 1  
oz. 1 3/8

Agitatore  
Shaker  
Shaker  
Shaker  
Coctelera

cl. 25 | oz. 8 1/2  
cl. 50 | oz. 16 7/8  
cl. 75 | oz. 25 3/8

729



10001151

mm. 1,2

Coppa per punch  
Punch bowl  
Bol à punch  
Punchbowl  
Cazo ponche

Ø cm. 38 | lt. 15  
Ø 15" | 4 gal.

Mestolo coppa per punch  
Punch bowl ladle  
Cuiller à punch  
Bowlenlöffel  
Cazo ponche

551



colori a pag. 253  
available colors at page 253  
couleurs disponibles  
à page 253  
Sehen Sie erhaltlichen Farben  
an Seite 253  
Ver colores à pagina 253

mm. 0,8

Agitatore Boston con bicchiere  
Boston shaker  
Boston shaker à cocktail et verre  
Boston Shaker  
Coctelera Boston

cl. 75 | oz. 25 3/8



380



382  
Lungh. cm. 17,5  
Length 6<sup>7</sup>/<sub>8</sub>"

mm. 1,5

mm. 1,2

ERGONOMICA  
Secchiello e molla per ghiaccio  
Ice bucket and ice tongs  
Seau à glaçons et pince à glaçons  
Eisgefäß und Eiszange  
Cubitera hielo y pinzas hielo

cl. 200

oz. 67 <sup>5</sup>/<sub>8</sub>

381



mm. 1,2

ERGONOMICA  
Secchiello per spumante  
Sparkling wine cooler  
Seau à champagne  
Wein-und Sektkühler  
Cubo para champany

lt. 4,5

gal. 1<sup>1</sup>/<sub>4</sub>

683



mm. 1,2

Secchio per ghiaccio  
Ice bucket with grill  
Seau à glaçons  
Eisgefäß  
Cubitera hielo

Ø cm.14  
H.cm.13  
cl. 150

Ø 5<sup>1</sup>/<sub>2</sub>"  
H. 5<sup>1</sup>/<sub>8</sub>"  
oz. 50<sup>3</sup>/<sub>4</sub>

mm. 1,2

Secchio per spumante  
Sparkling wine cooler  
Seau à champagne  
Wein-und Sektkühler  
Cubo para champany

Ø cm.23  
H cm.22,5  
lt. 8,5

Ø 9"  
H 8<sup>7</sup>/<sub>8</sub>"  
gal. 2<sup>1</sup>/<sub>4</sub>

684



941



mm. 1,2

Portacannuce  
Straw holder  
Porta pailles  
Strohalm Halter  
Porta-palillas

Ø cm. 9

Ø 3 <sup>1</sup>/<sub>4</sub>"

10001150



mm. 1,2

Golf club mixer spoon  
Golf club mixer spoon  
Golf crosse pour cocktail  
Golf Schleger für Long drink  
Golf club cucharita coctél

cm. 16,5

6 <sup>1</sup>/<sub>2</sub>"

686



NEW

mm. 1,2 | Champagnera 5 bott. c/pied.  
Giant Champagne bucket 5 bot.  
Seau à champagne p/5 bout.  
Champagner Bowl 5 Fäsche  
Cubo para champagne p/5 bot.

Ø cm. 40	Ø 15 3/4"
H cm. 38,5	H 15 1/6"
lt. 15	gal. 4

NEW



685

mm. 1,2 | Champagnera 5 bott. s/pied.  
Giant Champagne bucket 5 bot.  
Seau à champagne p/5 bout.  
Champagner Bowl 5 Fäsche  
Cubo para champagne p/5 bot.

Ø cm. 40	Ø 15 3/4"
H cm. 21,8	H 8 3/5"
lt. 15	gal. 4

438



mm. 1,2 | OVO  
Secchiello per spumante  
Sparkling wine cooler  
Seau à champagne  
Wein- und Sektkühler  
Cubo para champany

Ø cm. 19	Ø 7 1/2"
H cm. 22	H 8 5/8"
lt. 4,5	gal. 1 1/4

439



mm. 1,2 | OVETTO  
Secchiello per ghiaccio  
Ice-bucket  
Seau à glaçons  
Eisgefäß  
Cubitera hielo

Ø cm. 11	Ø 4 3/8"
H cm. 13	H 5 1/8"
cl. 100	oz. 33 7/8

689



mm. 1,2 | Secchiello per spumante  
Sparkling wine cooler  
Seau à champagne  
Wein- und Sektkühler  
Cubo para champany

Ø cm. 19	Ø 7 1/2"
H cm. 20	H 7 3/4"
lt. 2,5	oz. 84 1/2

688



mm. 1,2 | Secchiello per ghiaccio  
Ice-bucket  
Seau à glaçons  
Eisgefäß  
Cubitera hielo

Ø cm. 11	Ø 4 3/8"
H cm. 12,5	H 4 7/8"
cl. 55	oz. 18 5/8



972

973



972

973

973P

972P

mm. 1,2  
**972-972P**  
 PALACE  
 Secchiello per ghiaccio  
 Ice bucket  
 Seau à glaçons  
 Eisgefäß  
 Cubitera hielo

Ø cm 15    Ø 5 1/8"  
 H cm 18    H 7 1/8"  
 cl. 150      oz. 50 3/4

mm. 1,2  
**973-973P**  
 PALACE  
 Secchiello per spumante  
 Sparkling wine cooler  
 Seau à champagne  
 Wein- und Sektkühler  
 Cubo para champany

Ø cm 20,5    Ø 8 1/8"  
 H cm 24,5    H 9 5/8"  
 lt. 5,0        gal. 1 1/3

666F

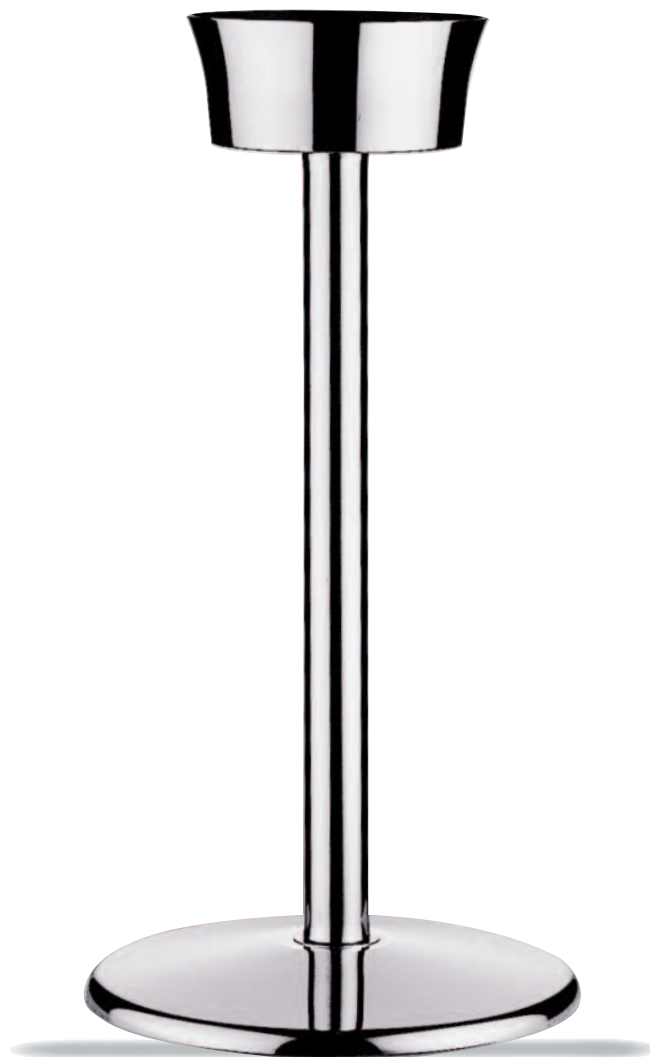

mm. 1,2  
**PALACE**  
 Colonna portasecchiello spumante  
 Wine cooler stand w/weighted base  
 Pied pour seau à champagne  
 Weinkühlerständer  
 Columna porta cubo champany

H cm. 67,5    H 26 5/8"

84501



84504



856



843



mm. 1,2 | DOLCE VITA  
Portaggiaccio termico con coperchio  
Insulated ice-bucket with lid  
Seau à glaçons thermique  
avec couvercle  
Isolier-Eisgefäß  
Cubitera hielo con tapa

Ø cm 14 | Ø 5 1/2"  
H cm 13 | H 5"  
cl.72 | oz. 24 1/3  
Ø cm 24 | Ø 9 1/2"  
H cm 22 | H 8 5/8"  
lt. 4,0 | gal. 1

mm. 1,2 | DOLCE VITA  
Secchiello per spumante  
Sparkling wine cooler  
Seau à champagne  
Wein- und Sektkühler  
Cubo para champany

Ø cm 14 | Ø 5 1/2"  
H cm 13 | H 5"  
cl.125 | oz. 42 1/4  
Ø cm 24 | Ø 9 1/2"  
H cm 22 | H 8 5/8"  
lt. 4,0 | gal. 1

666G

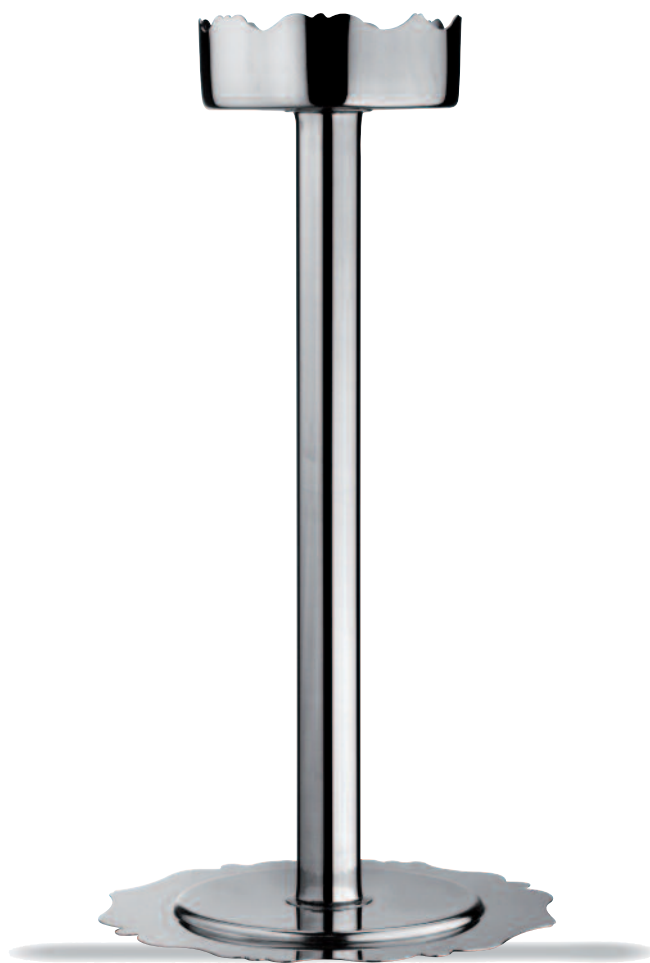

mm. 1,2 | DOLCE VITA  
Colonna portasecchiello spumante  
Wine cooler stand  
Pied pour seau à champagne  
Weinkühlerstand  
Columna porta cubo champany

H cm. 62 | H 24 3/8"



670



664



**670 mm.1,2**  
 Secchiello per ghiaccio  
 Ice bucket with grill  
 Seau à glaçons  
 Eisgefäß  
 Cubitera hielo  
 Ø cm.14 - H cm.13 - cl. 150  
 Ø 5 1/2" - H 5 1/8" - oz. 50 3/4

**662 mm.1,2**  
 Rinfrescavino bianco da 1 bottiglia  
 White wine cooler for 1 bottle  
 Seau à vin blanc  
 Weissweinkühler für 1 Flasche  
 Cubo para refrescar 1 botella de vino blanco  
 Ø cm.16 - H cm.20 - lt. 3  
 Ø 6 1/4" - H 7 7/8" - oz. 101 1/2

**663 mm.1,2**  
 Rinfrescavino bianco da 1 bottiglia  
 White wine cooler for 1 bottle  
 Seau à vin blanc  
 Weissweinkühler für 1 Flasche  
 Cubo para refrescar 1 botella de vino blanco  
 Ø cm.18 - H cm.21 - lt. 4,5  
 Ø 7 1/8" - H 8 1/4" - gal. 1 1/4

**664 mm.1,2**  
 Rinfrescavino spumante da 2/3 bottiglie o Magnum  
 Sparkling wine cooler for 2/3 bottles or Magnum  
 Seau à champagne 2/3 bouteilles ou Magnum  
 Champagnerkühler für 2/3 Flaschen oder Magnum  
 Cubo para refrescar 2/3 botellas de vino spumante  
 Ø cm.22,5 - H cm.23 - lt. 8,5  
 Ø 8 7/8" - H 9" - gal. 2 1/4

666

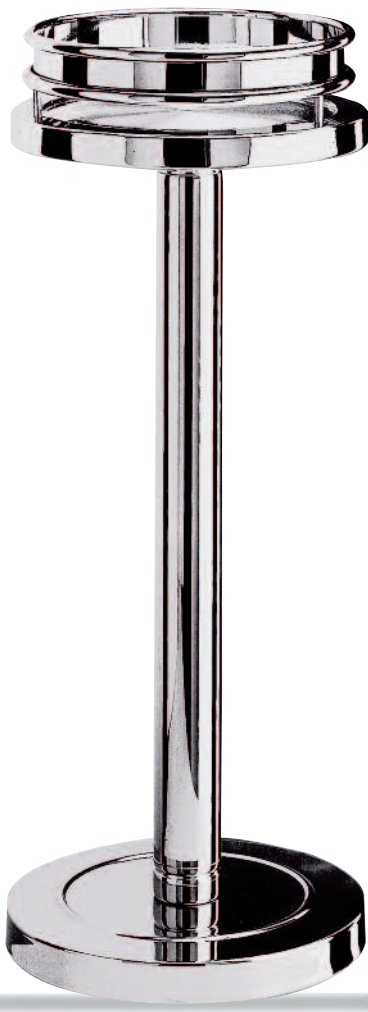

mm. 1,2 | Colonna portasecchiello spumante | H cm. 65 | H 25 5/8"  
 Wine cooler stand  
 Pied pour seau à champagne  
 Weinkühlerständer  
 Columna porta cubo champany

67704



67701

mm. 0,8 | Portaghiaccio termico con coperchio | lt. 3/4 | oz. 25 3/8  
 Insulated ice-bucket with lid | lt. 4 | gal. 1  
 Seau à glaçon thermique avec couvercle  
 Isolier-Eisgefäß  
 Cubitera hielo con tapa

676



mm. 0,8 | Glacette termica per 1 bottiglia | Ø cm. 13 | Ø 5 1/8"  
 Insulated glacette for 1 bottle | H cm. 20 | H 7 7/8"  
 Glacette thermique pour 1 bouteille | cl. 150 | oz. 50 3/4  
 Getränkeköhler 1 Flasche  
 Cubo térmico para 1 botella

681



681 mm.1,2

Rinfrescavino spumante da 2/3 bottiglie o Magnum  
Sparkling wine cooler for 2/3 bottles or Magnum  
Seau à champagne 2/3 bouteilles ou Magnum  
Champagnerkühler für 2/3 Flaschen oder Magnum  
Cubo para refrescar 2/3 botellas de vino spumante  
Ø cm.22,5 - H cm.23 - lt. 8,5  
Ø 8<sup>7</sup>/<sub>8</sub>" - H 9" - gal. 2<sup>1</sup>/<sub>4</sub>

680 mm.1,2

Rinfrescavino bianco da 1 bottiglia  
White wine cooler for 1 bottle  
Seau à vin blanc  
Weissweinkühler für 1 Flasche  
Cubo para refrescar 1 botella de vino blanco  
Ø cm.18 - H cm.21 - lt. 4,5  
Ø 7<sup>1</sup>/<sub>8</sub>" - H 8<sup>1</sup>/<sub>4</sub>" - gal. 1<sup>1</sup>/<sub>4</sub>



679 mm.1,2

Rinfrescavino bianco da 1 bottiglia  
White wine cooler for 1 bottle  
Seau à vin blanc  
Weissweinkühler für 1 Flasche  
Cubo para refrescar 1 botella de vino blanco  
Ø cm.16 - H cm.20 - lt. 3  
Ø 6<sup>1</sup>/<sub>4</sub>" - H 7<sup>7</sup>/<sub>8</sub>" - oz. 101<sup>1</sup>/<sub>2</sub>



678

678 mm.1,2

Secchiello per ghiaccio  
Ice bucket with grill  
Seau à glaçons  
Eisgefäß  
Cubitera hielo  
Ø cm.14 - H cm.13 - cl. 150  
Ø 5<sup>1</sup>/<sub>2</sub>" - H 5<sup>1</sup>/<sub>8</sub>" - oz. 50<sup>3</sup>/<sub>4</sub>

672



mm. 1,2

Portaghiaccio termico con anello e molla  
Insulated ice-bucket with handle and tongs for ice  
Seau à glaçon thermique avec anse et pinçe  
Isolier-Eisgefäß und Eiszange  
Cubitera hielo con asa y pinzas hielo

lt. 3/4 oz. 25<sup>3</sup>/<sub>8</sub>

666A

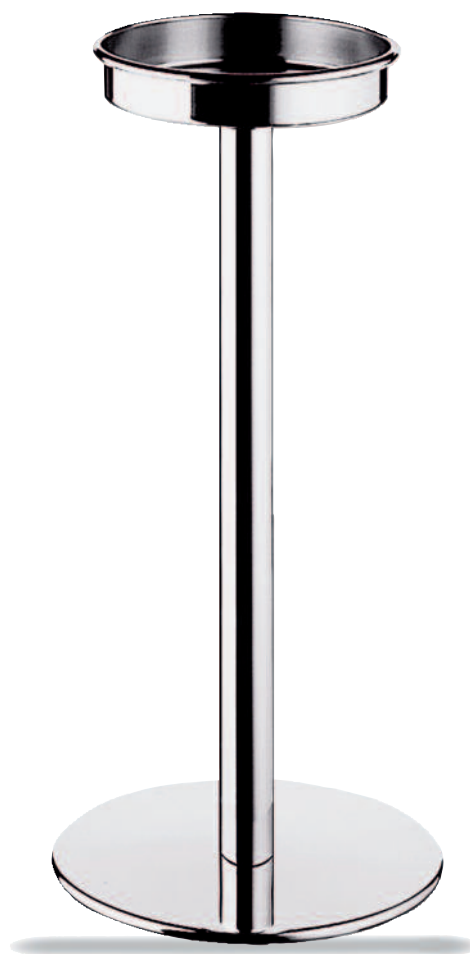

mm. 1,2

GALA  
Colonna portasecchiello spumante  
Wine cooler stand  
Pied pour seau à champagne  
Weinkühlerständer  
Columna porta cubo champany

H cm. 60

H 23<sup>5</sup>/<sub>8</sub>"

660



mm. 0,8

Servizio per champagne  
Insulated Champagne set  
Service pour champagne  
Champagnergetränk Kühler  
Servicio para champagne

Ø cm. 26  
H cm. 22  
cl. 150

Ø 10<sup>1</sup>/<sub>4</sub>"  
H 8<sup>2</sup>/<sub>3</sub>"  
oz. 50<sup>3</sup>/<sub>4</sub>



67301



67304

669



668

mm. 1,2

GIOTTO  
Portaggiaccio termico con coperchio  
Insulated ice-bucket with lid  
Seau à glaçons thermique  
avec couvercle  
Isolier-Eisgefäß  
Cubitera hielo con tapa

Ø cm 14	Ø 5 1/2"
H cm 13	H 5"
cl.72	oz. 24 1/3
Ø cm 24	Ø 9 1/2"
H cm 22	H 8 5/8"
lt. 4,0	gal. 1

mm. 1,2

GIOTTO  
Secchiello spumante e ghiaccio  
Sparkling wine cooler / Ice bucket  
Seau à champagne et à glaçons  
Wein- Sektkühler / Eisgefäß  
Cubo para champany y para hielo

Ø cm 24	Ø 9 1/2"
H cm 23	H 9"
lt. 5,0	gal. 1 1/3
Ø cm 14,5	Ø 5 2/3"
H cm 13	H 5 1/8"
lt. 1,4	oz. 47 1/3

666E

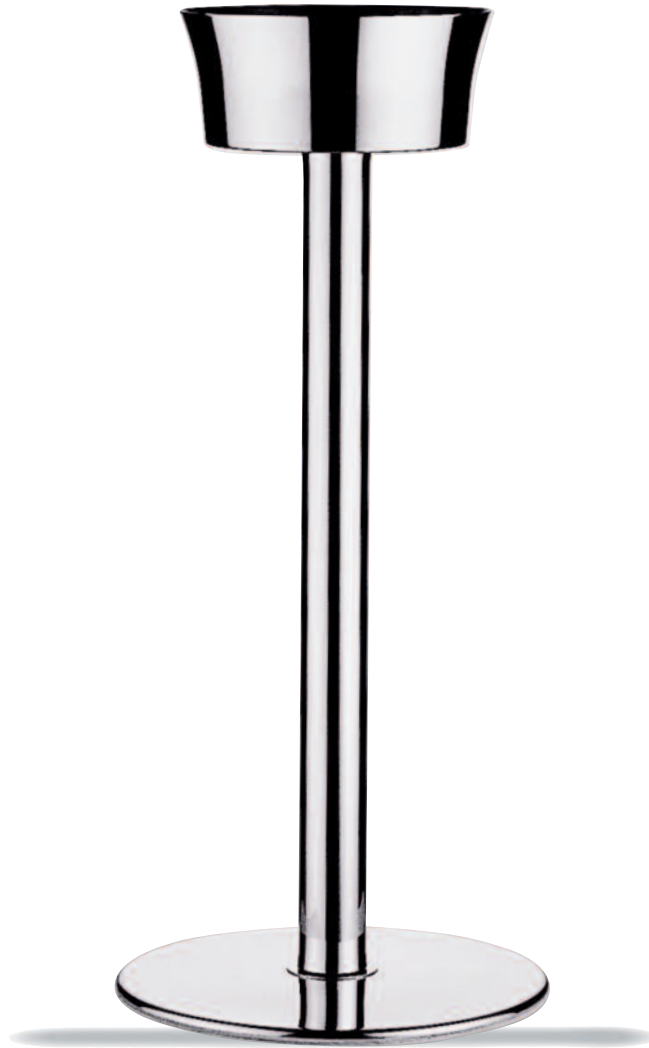

mm. 1,2

GIOTTO  
Colonna portasecchiello spumante  
Wine cooler stand  
Pied pour seau à champagne  
Weinkühlerständer  
Columna porta cubo champany

H cm. 67,5	H 26 5/8"
------------	-----------

370



mm. 1,2 | IMMAGINA  
 Secchiello per spumante  
 Sparkling wine cooler  
 Seau à champagne  
 Wein- und Sektkühler  
 Cubo para champany

cm 27 x 20,5 | 10 5/8" x 8"  
 H cm 21,5 | H 8 1/2"  
 lt. 6,5 | gal. 1 3/4

371



mm. 1,2 | IMMAGINA  
 Secchiello per ghiaccio  
 Ice bucket  
 Seau à glaçons  
 Eisgefäß  
 Cubitera para hielo

cm 16,6 x 10 | 6 1/2" x 4"  
 H cm 14,2 | H 8 1/2"  
 cl. 180 | oz. 60 7/8

666H



mm. 1,2 | IMMAGINA  
 Colonna portasecchiello spumante  
 Wine cooler stand  
 Pied pour seau à champagne  
 Weinkühlerständer  
 Columna porta cubo champany

H cm. 61,5 | H 24 1/5"



597



mm. 1,2	UNO	Ø cm. 16,8	Ø 6 5/8"
	Secchiello per ghiaccio	H cm. 11	H 4 3/8"
	Ice bucket	cl. 150	oz. 50 3/4
	Seau à glaçons		
	Eisgefäß		
	Cubitera hielo		

598



mm. 1,2	UNO	Ø cm. 29	Ø 11 3/8"
	Secchiello per spumante	H cm. 18,5	H 7 1/4"
	Sparkling wine cooler	lt. 8	gal. 2
	Seau à champagne		
	Wein- und Sektkühler		
	Cubo para champany		

666W

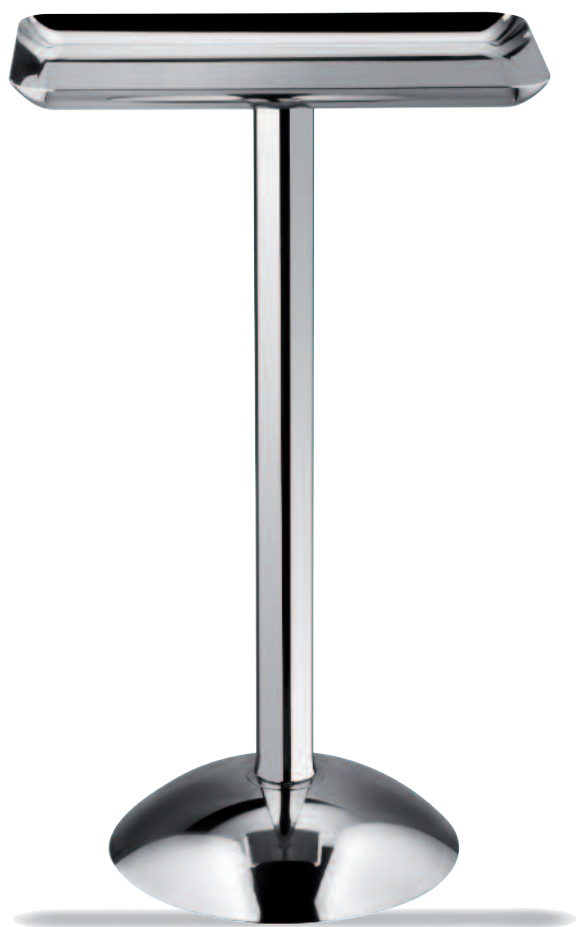

mm. 1,2	Gueridon d'appoggio rettangolare	H cm. 62	H 24 2/5"
	Rectangular gueridon	cm. 38 x 25	15" x 9 7/8"
	But de canapé rectangulaire		
	Gueridon, rechteckig		
	Gueridon rectangular		

666Z



mm. 1,2	Gueridon d'appoggio ovale	H cm. 62	H 24 2/5"
	Oval gueridon	cm. 46 x 31	18 1/8" x 12 1/4"
	But de canapé oval		
	Gueridon, oval		
	Gueridon oval		

599



mm. 1,2 | UNO  
Secchiello per spumante  
Sparkling wine cooler  
Seau à champagne  
Wein- und Sektkühler  
Cubo para champany

Ø cm. 29 | Ø 11 3/8"  
H cm. 18,5 | H 7 1/4"  
lt. 8 | gal. 2

596



mm. 1,2 | Secchiello per ghiaccio  
Ice bucket  
Seau à glaçons  
Eisgefäß  
Cubitera hielo

Ø cm. 16,8 | Ø 6 5/8"  
H cm. 11 | H 4 3/8"  
cl. 150 | oz. 50 3/4

599

**58928**

12 colori disponibili - pag. 253  
12 colors available - page 253  
12 couleurs disponibles - pag. 253  
12 verschiedenen Farben verfügbar - Seite 253  
12 colores disponibles - pag. 253

589 - Ø cm. 28  
Ø 11"



mm. 1,2 | UNO  
Cestino traforato  
Fretworked basket  
Corbeille, ajourée  
Früchtekorb gelocht  
Cesta perforada

Ø cm. 29 | Ø 11 3/8"  
H cm. 18,5 | H 7 1/4"  
lt. 8 | gal. 2

666C



mm. 1,2 | UNO  
Colonna portasecchiello spumante  
Wine cooler stand  
Pied pour seau à champagne  
Weinkühlerständer  
Columna porta cubo champany

H cm. 67,5 | H 26 5/8"





598

59870

Logo traforato a richiesta  
 Fretworked logo on demand  
 Logo ajourée sur demande  
 Firmenzeichen gelocht auf Verlangen  
 Logo perforado en demanda

589 - Ø cm. 64  
 Ø 25 1/4"

589 - Ø cm. 28  
 Ø 11"



mm. 1,2	<b>598</b>		
	Secchiello	Ø cm. 29	Ø 11 3/8"
	Basket	H cm. 18,5	H 7 1/4"
	Corbeille	lt. 8	gal. 2
	Früchtekorb Cesta		

mm. 1,2	<b>59870</b>		
	Big Champagnera	Ø cm. 67,5	Ø 26 5/8"
	Champagne bowl	H cm. 43	H 17"
	Bol a champagne	lt. 80	gal. 21
	Champagner Bowl Cesta para champany		



A



Ambra  
Amber  
Amber  
Amber  
Ambar



G



Granato  
Garnet  
Grenat  
Granat  
Granate

Q



Quarzo  
Quartz  
Quartz  
Quarz  
Cuarzo

M



Ametista  
Amethyst  
Amethyste  
Amethyst  
Amatista

W



Trasparente  
Transparent  
Glace  
Transparent  
Vidrio

Z



Zaffiro  
Sapphyre  
Saphir  
Saphir  
Zafiro

S



Smeraldo  
Emerald  
Emeraude  
Smaragd  
Esmeralda

V



Olivina  
Olivine  
Olivine  
Olivia  
Olivino

B



Berillo  
Beryll  
Beryl  
Beryl  
Berilo

O



Onice  
Onyx  
Onyx  
Onyx  
Onice



909



mm. 1,2 | Secchiello per ghiaccio forato  
Ice bucket fretworked handles  
Seau à glaçons anses ajourée  
Eisgefäß mit Griffen  
Cubitera hielo asa perforada

cm. 22 x 20 | 8<sup>3</sup>/<sub>4</sub>" x 7<sup>7</sup>/<sub>8</sub>"  
H cm. 11,5 | H 4 5<sup>5</sup>/<sub>8</sub>"  
lt. 1,2 | oz. 40 1<sup>1</sup>/<sub>2</sub>

912



mm. 1,2 | Secchiello per spumante forato  
Sparkling wine cooler fretw.handles  
Seau à champagne anses ajourée  
Wein- und Sektkühler mit Griffen  
Cubo para champany asa perforada

cm. 39 x 36 | 15<sup>3</sup>/<sub>8</sub>" x 14<sup>1</sup>/<sub>4</sub>"  
H cm. 17,5 | H 7"  
lt. 7 | gal. 1 4<sup>4</sup>/<sub>5</sub>

730



mm. 1,2 | Spumantiera 12 bottiglie champagne  
Giant champagne bucket for 12 bottles  
Seau à champagne géante pour 12 bouteilles  
Champagner Bowl für 12 Flaschen  
Cubo de champagne gigante para 12 botellas

cm. 75 x 65 | 29 1<sup>1</sup>/<sub>2</sub>" x 25 5<sup>5</sup>/<sub>8</sub>"  
H cm. 19 | H 7 1<sup>1</sup>/<sub>2</sub>"  
lt. 15 | gal. 3 7<sup>7</sup>/<sub>8</sub>

899



mm. 1,2 | Secchiello per ghiaccio  
Ice bucket  
Seau à glaçons  
Eisgefäß  
Cubitera hielo

cm. 22 x 20 | 8<sup>3</sup>/<sub>4</sub>" x 7<sup>7</sup>/<sub>8</sub>"  
H cm. 11,5 | H 4 5<sup>5</sup>/<sub>8</sub>"  
lt. 1,2 | oz. 40 1<sup>1</sup>/<sub>2</sub>

910



mm. 1,2 | Secchiello per spumante  
Sparkling wine cooler  
Seau à champagne  
Wein- und Sektkühler  
Cubo para champany

cm. 39 x 36 | 15<sup>3</sup>/<sub>8</sub>" x 14<sup>1</sup>/<sub>4</sub>"  
H cm. 17,5 | H 7"  
lt. 7 | gal. 1 4<sup>4</sup>/<sub>5</sub>

658

N E W



Cubetto luminoso confez. 72 pezzi LED ice cube 72 pcs. box Glaçons lumineux 72 pièces Eiswürfel LED 72 Stücke Cubito hielo LED 72 piezas	cm. 2,5 x 2,5 H cm. 2,5	1" x 1" H 1"
--	----------------------------	-----------------

Idoneo al contatto con gli alimenti.

Suitable for contact with food

Apte au contact alimentaire.

Materiale certificato:  
 LFGB - German Food,  
 Commodities and Animal Feed Code  
 of Law  
 DIN 10955 - 2004  
 ISO 11885:2007  
 BfR Recommendations on  
 Food Contact Materials - part V & VI  
 2010 & 2010  
 Regolamento CEE (EU) 10/2011  
 Regolamento CEE (EC) 1907/2006  
 Regolamento CEE (EC) 1935/2004

Certified material:  
 LFGB - German Food,  
 Commodities and Animal Feed Code  
 of Law  
 DIN 10955 - 2004  
 ISO 11885:2007  
 BfR Recommendations on  
 Food Contact Materials - part V & VI  
 2010 & 2010  
 Regulation CEE (EU) 10/2011  
 Regulation CEE (EC) 1907/2006  
 Regulation CEE (EC) 1935/2004

Matériel certifié:  
 LFGB - German Food,  
 Commodities and Animal Feed Code  
 of Law  
 DIN 10955 - 2004  
 ISO 11885:2007  
 BfR Recommendations on  
 Food Contact Materials - part V & VI  
 2010 & 2010  
 Réglementation CEE (EU) 10/2011  
 Réglementation CEE (EC) 1907/2006  
 Réglementation CEE (EC) 1935/2004

Durata delle batterie: 12 ore

Battery life: 12 hours

Vie de la batterie: 12 heures

Geeignet für Lebensmittel Kontakt.

Apto para el contacto con alimentos .

Zertifiziertes Material:  
 LFGB - German Food,  
 Commodities and Animal Feed Code  
 of Law  
 DIN 10955 - 2004  
 ISO 11885:2007  
 BfR Recommendations on  
 Food Contact Materials - part V & VI  
 2010 & 2010  
 Verordnung EWG (EU) 10/2011  
 Verordnung EWG (EC) 1907/2006  
 Verordnung EWG (EC) 1935/2004

Material certificado:  
 LFGB - German Food,  
 Commodities and Animal Feed Code  
 of Law  
 DIN 10955 - 2004  
 ISO 11885:2007  
 BfR Recommendations on  
 Food Contact Materials - part V & VI  
 2010 & 2010  
 Reglamento CEE (EU) 10/2011  
 Reglamento CEE (EC) 1907/2006  
 Reglamento CEE (EC) 1935/2004

Akkus Lebensdauer: 12 Stunden

Duración de la batería: 12 horas





# SPECIAL FINISHING

609B



mm. 1,2	Piano	cm. 40 x 36	15 3/4" x 14 1/8"
	Tray Plateau Tablett oval Bandeja		

612B



mm. 1,2	Piano forato	cm. 40 x 36	15 3/4" x 14 1/8"
	Tray fretworked handles Plateau avec anses ajourée Grifftablett oval Bandeja asa perforada		

613B



mm. 1,2	Fondo	cm. 22 x 20	8 5/8" x 7 7/8"
	Bowl		
	Bol	cm. 40 x 36	15 3/4" x 14 1/8"
	Obtschale oval Cuenco		

614B

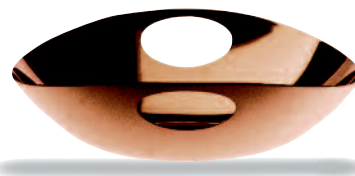

mm. 1,2	Fondo forato	cm. 22 x 20	8 5/8" x 7 7/8"
	Bowl fretworked handles		
	Bol avec anses ajourée	cm. 40 x 36	15 3/4" x 14 1/8"
	Griffschale oval Cuenco asa perforada		

617B



mm. 1,2	Sottopiatto ovale	cm. 34 x 31	13 3/8" x 12 1/4"
	Charger oval Assiette de bienvenue ovale Platzteller oval Bajo plato oval		

630B



mm. 1,2	Antipastiera	cm. 34 x 31	13 3/8" x 12 1/4"
	Hors d'oeuvre tray Plat à hors d'oeuvre Vorspeisenplatte Entremesera		



616B



mm. 1,2	Formaggera Parmesan cheese basin Fromagère Käsedose Quesera Azucarero	cm. 14 x 12 cl. 20	5 1/2" x 4 3/4" oz. 6 3/4
---------	---	-----------------------	------------------------------

615B



mm. 1,2	Completo oliera e spargisale Cruet and salt cellar set Service huile-vinaigre Essig-/Ölgestell 4-tlg. Convoy vinagreras y saleros	cm. 22x20 H cm. 19,6 cl. 30 (x2) cl. 8 (x2)	8 5/8" x 7 7/8" H 7 3/4" oz. 10 1/8 (x2) oz. 2 3/4 (x2)
---------	---	--	--

627B



mm. 1,2	Piano milleusi Multifunction tray Plateau oval multi usages Tablett mit Brett und 3 Porzellan Sossenschalen Bandeja oval multi usos	cm. 40 x 36	15 3/4" x 14 1/8"
---------	--	-------------	-------------------

350



Ampolla Cruet Huilliere Öl-/Essigflasche Vinagrera	H cm. 18 cl. 30  H 7 1/8" oz. 10 1/8	Salino Salt cellar Cristal pour sel et poivre Salz-Pfefferstreuer Salero	H cm. 8 cl. 8  H 3 1/8" oz. 2 3/4
--	--	---	---

616BAC



mm. 1,2	Piatino per pane Bread tray Plat pour pan Brot Platte Plato para pan	cm. 14 x 12	5 1/2" x 4 3/4"
---------	--	-------------	-----------------

61739B



mm. 1,2	Sottopiatto ovale magnum Charger oval Assiette de bienvenue ovale Platzteller oval Bajo plato oval	cm. 39 x 36	15 3/8" x 14 1/8"
---------	--	-------------	-------------------

# SPECIAL FINISHING

910B



mm. 1,2 | Secchiello per spumante  
Sparkling wine cooler  
Seau à champagne  
Wein- und Sektkühler  
Cubo para champany

cm. 39 x 36	15 <sup>3</sup> / <sub>8</sub> " x 14 <sup>1</sup> / <sub>4</sub> "
H cm. 17,5	H 7"
lt. 7	gal. 1 <sup>4</sup> / <sub>5</sub>

899B



mm. 1,2 | Secchiello per ghiaccio  
Ice bucket  
Seau à glaçons  
Eisgefäß  
Cubitera hielo

cm. 22 x 20	8 <sup>3</sup> / <sub>4</sub> " x 7 <sup>7</sup> / <sub>8</sub> "
H cm. 11,5	H 4 <sup>5</sup> / <sub>8</sub> "
lt. 1,6	oz. 54

912B

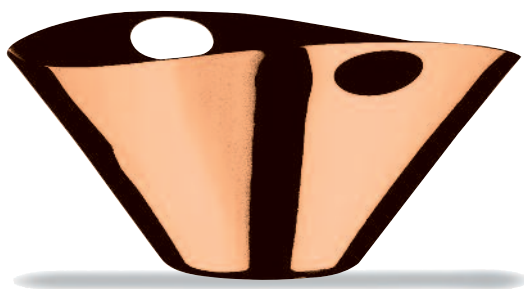

mm. 1,2 | Secchiello per spumante forato  
Sparkling wine cooler fretworked handles  
Seau à champagne anses ajourée  
Wein- und Sektkühler mit Griffen  
Cubo para champany asa perforada

cm. 39 x 36	15 <sup>3</sup> / <sub>8</sub> " x 14 <sup>1</sup> / <sub>4</sub> "
H cm. 17,5	H 7"
lt. 6	gal. 1 <sup>3</sup> / <sub>5</sub>

909B

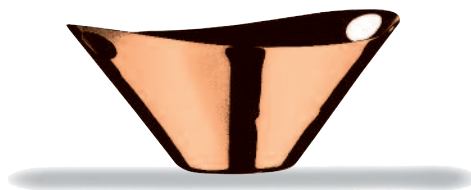

mm. 1,2 | Secchiello per ghiaccio forato  
Ice bucket fretworked handles  
Seau à glaçons anses ajourée  
Eisgefäß mit Griffen  
Cubitera hielo asa perforada

cm. 22 x 20	8 <sup>3</sup> / <sub>4</sub> " x 7 <sup>7</sup> / <sub>8</sub> "
H cm. 11,5	H 4 <sup>5</sup> / <sub>8</sub> "
lt. 1,2	oz. 40 <sup>1</sup> / <sub>2</sub>

## ACCIAIO

p. 231



609	612
613	614
617	630

p. 232

616	615
627	
616AC	61739

p. 233

910	899
912	909

## ICE ORO

p. 231



	101
	102
110	106

p. 232

105	104
113	
117	11039

p. 233

120	118
121	119

## ORO NERO

p. 231



	101N
	102N
110N	106N

p. 232

105N	104N
113N	
117N	11039N

p. 233

120N	118N
121N	119N

## BRONZO

p. 231

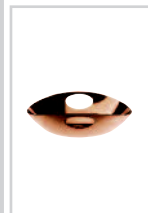

609B	612B
613B	614B
617B	630B

p. 232

616B	615B
627B	
616 BAC	61739B

p. 233

910B	899B
912B	909B





1001



mm. 1,2	Piano forato Tray fretworked handles Plateau avec anses ajourée Griffblett oval Bandeja asa perforada	cm. 40 x 36	15 3/4" x 14 1/8"
---------	---	-------------	-------------------

1002



mm. 1,2	Cestino/Portafrutta Bowl/Fruit holder Bol/Compotier Griffschale/Obstschale Cuenco/Fruterо	cm. 22 x 20 cl. 100	8 5/8" x 7 7/8" oz. 33 7/8
		cm. 40 x 36 cl. 200	15 3/4" x 14 1/8" oz. 67 5/8

1003



mm. 1,2	Sottopiatto Charger Assiette de bienvenue Platzteller Bajo plato	cm. 34 x 31	13 3/8" x 12 1/4"
---------	--	-------------	-------------------

1004



mm. 1,2	Sottobottiglia Bottle coaster Dessous de bouteille Flaschenteller Posabotella	cm. 14 x 12	5 1/2" x 4 3/4"
---------	---	-------------	-----------------

1005

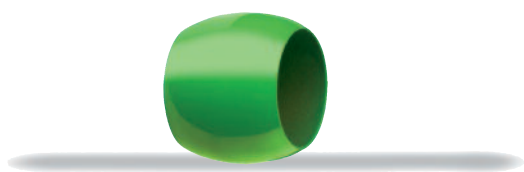

mm. 1,2	Allacciatovaglioli Napkins ring Rond de serviette Serviettenring Servilletero	Ø cm. 6	Ø 2 3/8"
---------	---	---------	----------



# SPECIAL FINISHING

1010



mm. 1,2	Centrotavola grande Big Centerpiece Grand Centre de table Grosse Tafelaufsatz Centro de mesa grande	cm. 39 x 36 H cm. 17,5 lt. 6	15 <sup>3</sup> / <sub>8</sub> " x 14 <sup>1</sup> / <sub>4</sub> " H 7" gal. 1 <sup>3</sup> / <sub>5</sub>
---------	---	------------------------------------	---

1009



mm. 1,2	Centrotavola piccolo Small Centerpiece Petit Centre de table Kleine Tafelaufsatz Centro de mesa pequeño	cm. 22 x 20 H cm. 11,5 lt. 1,2	8 <sup>3</sup> / <sub>4</sub> " x 7 <sup>7</sup> / <sub>8</sub> " H 4 <sup>5</sup> / <sub>8</sub> " oz. 40 <sup>1</sup> / <sub>2</sub>
---------	---	--------------------------------------	--

1006



mm. 1,2	Completo oliera e spargisale Cruet and salt cellar set Service huile-vinaigre Essig-/Ölgestell 4-tlg. Convoy vinagreras y saleros	cm. 22x20 H cm. 19,6 cl. 30 (x2) cl. 8 (x2)	8 <sup>5</sup> / <sub>8</sub> " x 7 <sup>7</sup> / <sub>8</sub> " H 7 <sup>3</sup> / <sub>4</sub> " oz. 10 <sup>1</sup> / <sub>8</sub> (x2) oz. 2 <sup>3</sup> / <sub>4</sub> (x2)
---------	---	--	---

1007



mm. 1,2	Formaggera Parmesan cheese basin Fromagère Käsedose Quesera Azucarero	cm. 14 x 12 cl. 20	5 <sup>1</sup> / <sub>2</sub> " x 4 <sup>3</sup> / <sub>4</sub> " oz. 6 <sup>3</sup> / <sub>4</sub>
---------	---	-----------------------	--

1008



mm. 1,2	Antipastiera Hors d'oeuvre tray Plat à hors d'oeuvre Vorspeisenplatte Entremesera	cm. 34 x 31	13 <sup>3</sup> / <sub>8</sub> " x 12 <sup>1</sup> / <sub>4</sub> "
---------	---	-------------	---



**J** Girasole  
Sunflower  
Tournesol  
Sonnengelb  
Girasol



**F7** Carota  
Carrot  
Carotte  
Mohrrübe  
Zanahoria



**S7** Rosso  
Red  
Rouge  
Signalrot  
Rojo



**A7** Mela verde  
Apple green  
Vert pomme  
Apfelgrün  
Verde Manzana



**V7** Viola  
Violet  
Violet  
Pflaume  
Violeta



**C** Cobalto  
Cobalt  
Cobalt  
Kobalt  
Cobalto

Acciaio verniciato con resina epossidica  
Epoxy resin-coated steel  
Acier recouvert de époxy-résine  
Stahl mit Epoxy-Lackierung  
Acero con recubrimiento epoxi



Possibilità di abbinare le posate FANTASIA a pagina 256, nelle stesse tonalità  
You can couple the cutlery FANTASIA of page 256, matching the same color tonality of this collection.

Vous pouvez coupler les couverts FANTASIA à la page 256, correspondant le même couleur de cette collection.

Die Farbtöne des Bestecks Fantasia (Seite 256) lassen sich mit den Farbtönen dieser Kollektion kombinieren.

Se puede acoplar los cubiertos FANTASIA en la página 256, igualando el mismo color de esta colección.





# Induction



- Prodotti High Tech.
- Efficienza energetica 100%.
- Ottimizzano le rese delle cucine professionali ad induzione più performanti.
- Altissimo spessore.
- Possibili finiture e loghi personalizzati.
- Non solo da nascondere in cucina, ma per il servizio al tavolo.

- High Tech products.
- 100% energy efficiency.
- Performance optimization of industrial kitchens at the highest level.
- Highest thickness.
- Possible to customize with personal logos and finishings.
- Suitable not only for the kitchen, but also for serving.

- Technologie de haute qualité.
- 100 % efficacité calorifique.
- Optimise les performances de cuisson au plus haut niveau.
- Fabrication forte épaisseur
- Il est possible de personnaliser et de faire des finitions spéciales.
- Ce type de matériel convient aussi en bien en cuisson en cuisine, qu'au service à table.

- Hightech Produkte.
- 100% Energieeffizient.
- Damit heben Sie Leistung & Effizienz Ihrer Profi-Küchen auf die höchste Stufe.
- Größtmögliche Materialstärken.
- Verschiedene Logoapplikationen und Finishings sind jederzeit möglich.
- Sowohl für den Einsatz im Küchen-, als auch im Servicebereich geeignet.

- Productos de alta tecnología.
- 100% Eficiencia energética.
- Optimiza el rendimiento de las cocinas de inducción profesional al más alto nivel.
- Gran espesor.
- Es posible aplicar logotipos personales y acabados especiales.
- No solo para esconderse en la cocina, sorprende en el servicio directo de mesa.







1821+1851

Tutte le pentole sono spedite con coperchio  
All the pots are delivered with lid  
Tous les marmites sont livrés avec le couvercle  
Alle Töpfe werden mit Deckel geliefert  
Todas las ollas son entregados con la tapa

1811+1851



	Ø cm.	Litri	Ø in.	Oz.
Mini casseruola 2 manici NON per piastre ad induzione NO INDUCTION mini casserole 2 handles Mini faitoute 2 man.NON pour induction Mini Bratentopf 2 Grif. NICHT für Induktion Mini cacerola 2 man. NO para la inducción	12	0,6	3 1/2" 4 7/8"	8 1/2 20 1/4

	Ø cm.	Litri	Ø in.	Oz.
Mini casseruola 1 manico NON per piastre ad induzione NO INDUCTION mini casserole 1 handle Mini faitoute 1 man.NON pour induction Mini Bratentopf 1 Griff NICHT für Induktion Mini cacerola 1 man. NO para la inducción	9	0,25	3 1/2"	8 1/2

1801+1851



1821+1851



	Ø cm.	Litri	Ø in.	Qt.
Pentola alta Deep pot Marmite Gemüsetopf Olla alta	24 22 20	6,5 5,0 3,5	9 1/2" 8 2/3" 7 7/8"	6 1/3 5 2/7 3 1/4

	Ø cm.	Litri	Ø in.	Qt.
Casseruola fonda 2 manici Deep casserole 2 handles Faitout 2 manches Bratentopf 2 Griffen Cacerola honda 2 mangos	24 22 20 18	5,0 3,5 3,0 2,0	9 1/2" 8 2/3" 7 7/8" 7"	5 2/7 3 1/4 3 1/6 2 1/9

1841-1851

1811+1851

1831+1851



	Ø cm.	Litri	Ø in.	Qt.
Padella 1 manico Frying pan Poêle a frire Bratpfanne Sartén	26	3,0	10 1/4"	3 1/8

	Ø cm.	Litri	Ø in.	Qt.
Tegame 2 manici Frying pan 2 handles Sauteuse 2 manches Bratpfanne 2 Griffen Rustidera 2 mangos	28 24	4,0 3,0	11" 9 1/2"	4 1/4 3 1/8

	Ø cm.	Litri	Ø in.	Qt.
Casseruola 1 m. Casserole 1 h. Faitout 1 man. Stielkasserolle Cacerola 1 m.	16 14	2,0 1,0	6 1/4" 5 1/2"	2 1/3 1





2179



2179

	Ø cm.	Ø in.
Padella	28	11"
Frying pan	24	9 1/2"
Poêle a frire	20	7 7/8"
Bratpfanne		
Sartén		

2131 + 2151

2121+2151



2101+2151



	Ø cm.	Litri	Ø in.	Qt.
Tegame con coperchio	32	5,0	10 1/4"	2 1/2
Frying pan with lid	26	2,7		
Sauteuse avec couvercle				
Bratpfanne mit Deckel				
Rustidera con tapa				

	Ø cm.	Litri	Ø in.	Qt.
Casseruola con coperchio	22	5,0	8 2/3"	5 2/7
Deep casserole with lid	20	3,5	7 7/8"	3 1/4
Faitout avec couvercle				
Bratentopf mit Deckel				
Cacerola honda con tapa				

	Ø cm.	Litri	Ø in.	Qt.
Pentola con coperchio	22	6,4	8 2/3"	5 7/8
Deep pot with lid				
Marmite avec couvercle				
Gemüsetopf mit Deckel				
Olla alta con tapa				

2111+2151



2178-2151



	Ø cm.	Litri	Ø in.	Qt.
Casseruola 1 m. c/coperchio	16	1,4	6 1/4"	1 1/4
Casserole 1 h. w/lid				
Faitout 1 man. a/couvercle				
Stielkasserolle m/Deckel				
Cacerola 1 m. c/tapa				

2180



	cm.	in.
Bistecchiera	28 x 28	11" x 11"
Grill pan		
Gril		
Grill Pfanne		
Bistequera		

	Ø cm.	Litri	Ø in.	Qt.
Wok	28	3,0	11"	3 1/8



2162+2151

	cm.	Litri	in.	Qt.
Casseruola ovale c/coperchio	30 x 24	5,1	11 4/5" x	5 3/7
Oval deep casserole w/lid	H 11		9 1/2"	
Cocotte ovale a/couvercle			H 4 1/3"	
Kasserolle, oval m/ Deckel				
Cazuela oval con tapa				



# Spa & Wellness



- Infrangibile
- Adatto alla lavastoviglie
- Adatto al forno a microonde
- Ideale per:
- Discoteche
- Yacht e navi da crociera
- Cliniche
- Case di riposo per anziani
- Asili

Ideale per tutti i luoghi dove i clienti possono accedere a piedi nudi:

- Piscine
- Spiagge
- Prati
- Centri di benessere
- Impianti sportivi
- Tonalità diverse disponibili a richiesta
- Possono essere personalizzati con logo, anche a più colori

- Unbreakable
- Dishwasher Safe
- Microwave Safe
- Ideale for:
- Night Clubs
- Yachts and Cruise Ships
- Hospitals and Medical
- Clinics
- Rest Homes
- Schools
- Perfect for Barefoot

- Environments:
- Swimming Pools
- Beaches
- Lawns
- Wellness Centers
- Fitness Centers
- Available in additional colors.
- Imprinting and logos available. Multicolor printing available.

- Incassable
- Utilisable au laves-vaisselles
- Utilisable au Four à micro-ondes
- Idéal pour :
- Discothèques
- Yacht et bateaux de croisière
- Cliniques
- Maisons de repos
- Crèches

Ideal pour tous les lieux où les clients peuvent accéder à pied nus :

- Piscines
- Plages
- Jardin
- Centre de bien-être



- Installations sportives
- Tonalités différentes disponibles sur demande  
Ils peuvent être personnalisés avec logo, multicouleurs, gravées ou lazer

- Unzerbrechlich
- Spülmaschinenfest
- Microwellenfest
- Daher bestens geeignet zum Gebrauch:
- in Cocktailbars & Night Clubs
- für Yachten und Kreuzfahrtschiffe
- in Kliniken und Heimen
- in Badezimmern
- für Schulen und Kindergärten

Auch aufgrund der Bruchsicherheit perfekt einzusetzen an Orten, die barfuß betreten werden:

- Schwimmbäder und Poolbereiche
- Strände und Strandbars
- Rasenflächen
- Wellnesscenter
- Fitnesscenter
- Alle Produkte sind auch in zusätzlichen, weiteren Farben erhältlich.
- Alle Produkte können auch mit Logos und Beschriftung individualisiert werden.
- Dabei ist auch mehrfarbiger Druck möglich.

- Irrompible
- Apto para lavavajillas
- Apto para microondas
- Ideal para:
- Discotecas
- Yates y barcos de crucero
- Clinicas
- Residencias de ancianos
- Asilos
- Ideal para todos los lugares donde los clientes pueden ir descalzos:
- Piscinas
- Playas
- Praderas
- Centros de bienestar
- Centros deportivos
- Tonos diversos disponibles por encargo
- Se pueden personalizar con logo, incluso en varios colores.





22004



Articolo venduto in posto tavola  
Sold as a 4pcs Place setting only  
Vendu comme un set de table 4 pièces  
Verkauf als Komplett-Set  
Se vende el juego 4 piezas

588



Bicchiere  
Glass  
Gobelet  
Glas  
Vaso

H cm 10  
cl. 33

H 3<sup>7</sup>/<sub>8</sub>"  
oz. 11 1/8

591



Bicchiere  
Glass  
Gobelet  
Glas  
Vaso

H cm 13  
cl. 45

H 5"  
oz 15 1/4

554



Fondo  
Bowl  
Bol  
Obstschale oval  
Cuenco

Ø cm. 18 | Ø 7"

553

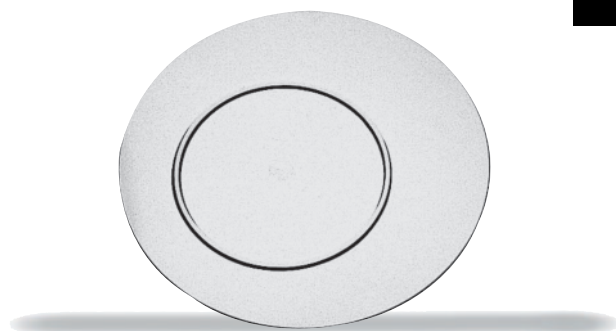

Piano  
Tray  
Plateau  
Tablett oval  
Bandeja

Ø cm. 27 | Ø 10 1/2"

555



Piano per buffet  
Tray for buffet  
Plateau pour buffet  
Buffettablett  
Bandeja para buffet

Ø cm. 27 | Ø 10 1/2"



589



Ciotola tonda  
Round bowl  
Bol ronde  
Früchtekorb, rund  
Cuenco redondo

Ø cm. 12	Ø 4 3/4"
H cm. 7,4	H 2 7/8"
cl. 40	oz. 13 1/2

605



Set impilabile di 3 coppette tonde  
Stackable set of 3 round bowls  
Set empilable de 3 bols ronde  
Stapelbarer Relish-Pickles-Gestell , rund  
Set impilable de 3 cuencos redondos

cl. 40 (x 3)	oz. 13 1/2 (x 3)
--------------	------------------

589



Ciotola tonda  
Round bowl  
Bol ronde  
Früchtekorb rund  
Cuenco redondo

Ø cm. 22	Ø 8 1/2"
H cm. 14	H 5 1/2"
cl. 220	oz. 74 3/8

589+599



589



Ciotola tonda  
Round bowl  
Bol ronde  
Früchtekorb rund  
Cuenco redondo

Ø cm. 28	Ø 11"
H cm. 17,3	H 6 5/8"
lt. 6,03	oz. 202 1/2

550



Mug

H cm 10 cl. 33	H 3 7/8" oz. 11 1/8
-------------------	------------------------

552



Piattino per mug e bicchieri (Art. 550,588,591) Mug coaster (Art. 550,588,591) Dessous de verre (Art. 550,588,591) Gläseruntersatz (Art. 550,588,591) Posavasos por mug (Art. 550,588,591)	Ø cm. 13,2	Ø 5 1/4"
--	------------	----------

592



Tazzina da caffè con piattino  
Express coffee cup and saucer  
Tasse de moka avec soucoupe  
Mokka Tasse mit Untertasse  
Taza de moka con platillo

cl 9	oz. 3
------	-------

593



Tazza da tè con piattino  
Tea cup and saucer  
Tasse de thé avec soucoupe  
Tee Tasse mit Untertasse  
Taza de tè con platillo

cl 15	oz 5 1/8
-------	----------

590



Ciotola quadra  
Square bowl  
Bol carrè  
Obstschale viereckig  
Cuenco cuadrado

cm. 10 x 10 cl. 27	3 7/8" x 3 7/8" oz. 9 1/8
-----------------------	------------------------------

606



Set impilabile di 3 coppette quadre  
Stackable set of 3 square bowls  
Set empilable de 3 bols carrè  
Stapelbarer Relish-Pickles-Gestell ,  
quadratisch  
Set impilable de 3 cuencos cuadrados

cl. 27 (x 3)	oz. 9 1/8 (x 3)
--------------	-----------------



542



Vassoio rettangolare  
Rectangular tray  
Plateau rectangulaire  
Tablett rechteckig  
Bandeja rectangular

cm. 24,5 x 18,5 | 9 3/4" x 7 3/8"  
H cm. 3 | H 1 1/4"

538



Ciotola rettangolare  
Rectangular bowl  
Bol rectangulaire  
Obtschale rechteckig  
Cuenco rectangular

cm. 24,5 x 18,5 | 9 3/4" x 7 3/8"  
H cm. 8,5 | H 3 3/8"

600



Caraffa per bibita  
Jug for drinks  
Carafe  
Saftkrug  
Jarra agua

lt. 1 | oz. 33 7/8

556



Paia posate per insalata  
Salad serving set  
Couverts à servir la salade  
Salatvorlege Service 2-Tlg.  
Cubiertos para ensalada 2 pzas.

Lung. cm. 27  
Long. 10 5/8"

536



Coppa per gelato  
Ice cream cup  
Coupe à glaçe  
Eisbecher  
Copa helado

H cm 12	H 4 3/4"
cl. 27	oz 9 1/8

535



Coppa Martini  
Martini glass  
Coupe à Martini  
Martini glas  
Vaso para Martini

H cm. 19	H 7 1/2"
cl 27	oz 9 1/8

534



Bicchiere per birra  
Beer glass  
Gobelet pour birre  
Bierbecher  
Vaso para cerveza

H cm. 17,5	H 6 7/8"
cl 45	oz 15 1/8

533



Bicchiere per vino  
Beverage glass  
Gobelet pour vin  
Weinbecher  
Vaso para vino

H cm. 24,5	H 9 1/3"
cl 45	oz 15 1/8

527

NEW



Bicchiere da whisky  
Whisky glass  
Gobelet pour whisky  
Whisky Becher  
Vaso para whisky

cl. 15	oz. 5 1/8
--------	-----------

NEW

531



Bicchiere da liquore  
Liquor glass  
Gobelet pour alcool  
Schnapsbecher  
Vaso para alcohol

cl. 9	oz. 3
-------	-------

543



Bicchiere per champagne  
Champagne glass  
Gobelet pour champagne  
Champagnerglas  
Vaso para champany

H cm. 22,7	H 9"
cl. 15	oz. 5 1/8







**A** Ambra  
Amber  
Ambre  
Amber  
Ambar



**G** Granato  
Garnet  
Grenat  
Granat  
Granate



**Q** Quarzo  
Quartz  
Quartz  
Quarz  
Cuarzo



**S** Smeraldo  
Emerald  
Émeraude  
Smaragd  
Esmeralda



**V** Olivina  
Olivine  
Olivine  
Olivia  
Olivino



**Z** Zaffiro  
Sapphyre  
Saphir  
Saphir  
Zafiro

Tutti gli articoli da pagina 246 a pagina 251 sono disponibili in 12 colori

All the items from page 246 to page 251 are available in 12 colors,

Toutes les articles da page 246 à page 251 sont disponibles en 12 couleurs

Alle Polycarbonat-Produkte von Seite 246 bis zu Seite 251 sind in 12 Farben bzw. Ausführungen erhältlich

Todos los artículos da pagina 246 à pagina 251 son disponibles en 12 colores,



**M** Ametista  
Amethyst  
Amethyste  
Amethyst  
Amatista



**W** Trasparente  
Transparent  
Glace  
Transparent  
Vidrio



**B** Berillo  
Beryl  
Beryl  
Beryl  
Berilo



**O** Onice  
Onyx  
Onyx  
Onyx  
Onice



**P** Porcellana  
White  
Porcelain  
Weiss  
Porcelana



**N** Nero  
Black  
Noir  
Schwarz  
Negro



886



Secchiello per ghiaccio  
Ice bucket  
Seau à glaçons  
Eisgefäß  
Cubitera hielo

Ø cm. 15	Ø 5 7/8"
H cm. 15	H 5 7/8"
cl. 150	oz. 50 3/4

888



Secchiello per spumante  
Sparkling wine cooler  
Seau à vin/glace  
Wein- und Sektkühler  
Cubo para champany

Ø cm. 22	Ø 8 5/8"
H cm. 22	H 8 5/8"
lt. 5	gal. 1 1/4

891



Bicchiere  
Glass  
Gobelet  
Glas  
Vaso

H cm. 13	H 5"
cl. 33	11 1/8 oz

892



Bicchiere  
Glass  
Gobelet  
Glas  
Vaso

H cm. 10	H 4"
cl. 25	8 2/5 oz

517

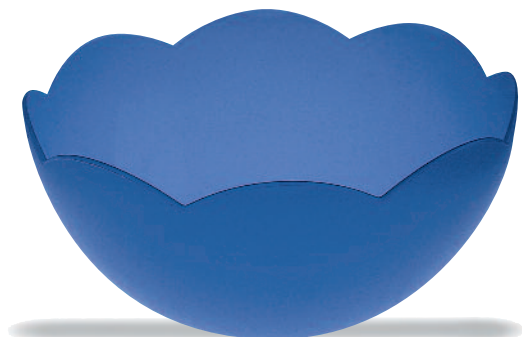

Ciotola  
Bowl  
Bol  
Obstschale  
Cuenco

Ø cm. 10	Ø 3 7/8"
cl. 30	oz. 10 1/8
Ø cm. 15	Ø 5 7/8"
cl. 60	oz. 20 1/4
Ø cm. 22	Ø 8 5/8"
cl. 200	oz. 67 5/8
Ø cm. 28	Ø 11"
lt 4	gal. 1

099



Sottopiatto  
Charger  
Assiette de bienvenue  
Platzteller  
Bajo plato

CARAMELLA	Ø cm. 32	Ø 12 5/8"
"		
"		
"		

093



**W** Ghiaccio  
Ice  
Glace  
Eis  
Hielo



**O** Arancio  
Orange  
Orange  
Orange  
Naranja



**G** Limone  
Lemon  
Jaune  
Zitrone  
Amarillo



**E** Verde acido  
Acid green  
Vert acide  
Azid Grün  
Pistacho



**B** Anice  
Anis  
Bleu  
Blau  
Azul



**U** Luce di Wood  
Wood light  
Lumière de Wood  
Schwarzlicht  
Luz de Wood  
Solo art. 891 - 892  
Only for art. 891 - 892  
Seulement pour art. 891 - 892  
Nur für Art. 891 - 892  
Solo para art. 891 - 892

Tutti gli articoli di pagina 254 sono disponibili in 5 colori

All the items of page 254 are available in 5 colors

Toutes les articles de page 254 sont disponibles en 5 couleurs

Alle Produkte von Seite 254 sind in 5 Farben bzw. Ausführungen erhältlich

Todos los artículos de pagina 254 son disponibles en 5 colores



FANTASIA  
MILLENNIUM



01



Lunghezza 197 mm  
Length 7 3/4"

Cucchiaino tavola  
Table spoon  
Cuillère table  
Tafellöffel  
Cuchara mesa

02



Lunghezza 197 mm  
Length 7 3/4"

Forchetta tavola  
Table fork  
Fourchette table  
Tafelgabel  
Tenedor mesa

03



Lunghezza 223 mm  
Length 8 3/4"

Coltello tavola  
Table knife  
Couteau table  
Tafelmesser  
Cuchillo mesa

04



Lunghezza 174 mm  
Length 6 7/8"

Cucchiaino frutta  
Fruit spoon  
Cuillère dessert  
Dessertlöffel  
Cuchara postre

05



Lunghezza 175 mm  
Length 6 8/9"

Forchetta frutta  
Fruit fork  
Fourchette dessert  
Dessertgabel  
Tenedor postre

06



Lunghezza 197 mm  
Length 7 3/4"

Coltello frutta  
Fruit knife  
Couteau dessert  
Dessertmesser  
Cuchillo postre

07



Lunghezza 133 mm  
Length 5 1/4"

Cucchiaino caffè  
Tea spoon  
Cuillère à café  
Kaffelöffel  
Cuchara café

10



Lunghezza 235 mm  
Length 9 1/4"

Cucchiaino  
Cooking spoon  
Cuillère à légumes  
Gemüselöffel  
Cuchara legumbres

11



Lunghezza 235 mm  
Length 9 1/4"

Forchettone  
Cooking fork  
Fourchette à légumes  
Fleischgabel  
Tenedor legumbres

15



Lunghezza 157 mm  
Length 6 1/5"

Forchettina dolce  
Cake fork  
Fourchette à gateaux  
Kuchengabel  
Tenedor pastel

16

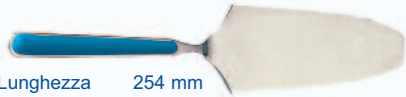

Lunghezza 254 mm  
Length 10"

Pala per torta  
Cake trowel  
Pelle à tarte  
Tortenheber  
Pala tarta

20



Lunghezza 198 mm  
Length 7 4/5"

Paletta pesce tavola  
Table fish knife  
Couteau poisson  
Fischmesser  
Pala pescado

21



Lunghezza 195 mm  
Length 7 2/3"

Forchetta pesce tavola  
Table fish fork  
Fourchette poisson  
Fischgabel  
Tenedor pescado

22



Lunghezza 233 mm  
Length 9 1/6"

Cucchiaino insalata a servire  
Salad spoon  
Cuillère à salade  
Salatvorlegelöffel  
Cuchara ensalada

23



Lunghezza 233 mm  
Length 9 1/6"

Forchetta insalata a servire - Salad fork  
Fourchette à salade  
Salatvorlegelöffel  
Tenedor ensalada

40



Lunghezza 185 mm  
Length 7 1/4"

Mestolino salsa  
Ladle sauce  
Cuillère à sauce  
Saucenlöffel  
Cacillo salsa

42



Lunghezza 290 mm  
Length 11 2/5"

Forchetta per fonduta  
Fondue fork  
Fourchette à fondue  
Fonduegabel  
Tenedor para fondue

43



Lunghezza 277 mm  
Length 10 8/9"

Cucchiaino risotto  
Vegetable spoon  
Cuillère à "risotto"  
Gemüselöffel  
Cuchara para arroz seco



COLORI DISPONIBILI  
 AVAILABLE COLORS  
 COULEURS DISPONIBLES  
 VERFÜGBARE FARBEN  
 COLORES DISPONIBLES

**N**

Nero  
 Black  
 Noir  
 Schwarz  
 Negro



**I**

Vigogna  
 Vicuna  
 Vigogne  
 Grau  
 Vicuña



**S**

Salvia  
 Sage  
 Sauge  
 Salbei  
 Salvia



**W**

Porcellana  
 China  
 Porcelaine  
 Porzellan  
 Porcelana



**P**

Wengé



**I7**

Ciocolato  
 Chocolate  
 Chocolat  
 Schokolade  
 Chocolate



**m**

Tabacco  
 Tobacco  
 Tabac  
 Tabak  
 Tabaco



**R**

Rovere sbiancato  
 Bleached wood  
 Chêne  
 Holz eiche  
 Blanqueado



**V7**

Viola  
 Violet  
 Violet  
 Pflaume  
 Violeta



**B7**

Ciclamino  
 Light mauve  
 Cyclamene  
 Bordeaux  
 Morado



**H7**

Lilla  
 Lilac  
 Lilas  
 Lila  
 Lila



**P7**

Rosa  
 Pink  
 Rose  
 Pink  
 Rosa



**Z7**

Rosa pallido  
 Pale rose  
 Rose pâle  
 Zartrose  
 Rosa Palido



**C**

Cobalto  
 Cobalt  
 Cobalt  
 Kobalt  
 Cobalto



**B**

Blu  
 Blue  
 Bleu  
 Blau  
 Azul



**M7**

Carta da zucchero  
 Sugar paper  
 Papier de Sucre  
 Pastelblau  
 Papel de Azucar



**N7**

Petrolio  
 Petroleum  
 Pétrole  
 Petroleum  
 Petróleo



**K7**

Blu elettrico  
Electric blue  
Bleu Electrique  
Kornblume  
Azul Electrico



**D7**

Lavanda  
Lavendal  
Lavande  
Lavendal  
Lavanda



**A**

Azzurro  
Light blue  
Bleu Ciel  
Azurblau  
Celeste



**X**

Bordeaux  
Claret red  
Bordeaux  
Bordeaux  
Burdeos



**S7**

Rosso  
Red  
Rouge  
Rot  
Rojo



**K**

Corallo  
Coral  
Corail  
Koralle  
Coral



**C7**

Nuovo Corallo  
New Coral  
Nouveau Corail  
Koralle neu  
Nuevo Coral



**F7**

Carota  
Carrot  
Carotte  
Mohrrübe  
Zanahoria



**O**

Arancio  
Orange  
Orange  
Orange  
Naranja



**J**

Girasole  
Sunflower  
Tournesol  
Sonnengelb  
Girasol



**G**

Giallo  
Yellow  
Jaune  
Gelb  
Amarillo



**L7**

Lime  
Lime  
Lime  
Limone  
Lima



**L**

Vaniglia  
Vanilla  
Vanille  
Vanille  
Vainilla



**T**

Tortora  
Turtle-dove  
Tourterelle  
Turteltaube  
Tortola



**V**

Verde  
Green  
Vert  
Grün  
Verde



**A7**

Mela verde  
Apple green  
Vert pomme  
Apfelgrün  
Verde Manzana



**E**

Verde acido  
Acid green  
Vert acide  
Pistazie  
Pistacho



**G7**

Verde Prato  
Green Meadow  
Vert Gazon  
Wiesengrün  
Verde Prado



**Q7**

Oliva  
Olive-green  
Olive  
Olivegrün  
Oliva



**Q**

Acquamarina  
Aquamarine  
Aigue-marine  
Aquamarin  
Agua marina





# Trolleys



- Carrelli multifunzionali  
Vasta gamma di accessori disponibili
- Molteplici finiture
- Ruote speciali a grandezza maggiorata, fascia in gomma antistatica e antitraccia
- Angolari rinforzati
- Logo a richiesta

- Multifunctional trolleys
- A complete range of optional accessories
- Numerous customization choices
- The oversized wheels are anti-static, won't leave marks.
- Reinforced legs
- Company logo on demand

- Chariots multifonctions
- Complète dotation d'accessoires disponibles
- Variété de finitions
- Roulettes surdimensionnées spéciales, avec bande en caoutchouc synthétique conducteur antitraçage
- Arêtes renforcées
- Logo à la demande

- Multifunktioneller Trolley
- Grosse Auswahl von optionalem Zubehör
- Grosse Auswahl von Oberflächen- Variationen und Lack-Farben
- Besonders grossdimensionierte Rollenmitantistatischen Gummireifen, die keinen Abrieb hinterlassen
- Spezialverstärkte Beine
- Ihr Firmen-Logo auf Wunsch als Option

- Carros multifunción
- Vasta gama de accesorios opcionales
- Múltiples acabados
- Ruedas especiales de mayor tamaño, con cinta de goma antistática y antihuellas
- Angulares reforzados
- Logo a solicitud

**MEPRA**  
S.p.A.

# TROLLEYS

## BUENOS AIRES

Gueridon



H cm 80  
cm 50 x 50

H 31 1/2"  
19 3/4" x 19 3/4"

## DELUXE

011



012



Massello con angolari in acciaio inossidabile 18/10  
Solid wood with 18/10 Stainless Steel legs  
Massif avec arêtes en inox 18/10  
Massivholz, Beine mit Edelstahl Rostfrei 18/10  
Profilen verblendet  
Tablero con angulares en acero inox 18/10

## CHIC

013



014



015



Pannello nobilitato laccato lucido  
Glossy, lacquered, laminated panel  
Panneaux noble laqués  
Glänzend, lackierte, laminierte Paneele  
Tablero chapado lacado brillo

## VIP

016



017



Massello con angolari in massello  
Trolley and solid wood legs  
Panneaux massif avec hanches massif  
Trolley und Beine komplett aus Massivholz  
Tablero macizo con angulares macizos

## COLORI

015	013	011 016	012 017	014
Bianco White Blanc Weiss Blanco	Oro Gold Or Gold Oro	Noce Walnut Noyer Walnuss Nuez	Wengè	Nero Black Noir Schwarz Negro



# TROLLEYS

## LONDON



Gueridon

H cm 80  
cm 60 x 40

H 31 1/2"  
23 5/8" x 15 3/4"

H cm 80  
cm 80 x 40

H 31 1/2"  
31 1/2" x 15 3/4"

## DELUXE

031



032



Massello con angolari in acciaio inossidabile 18/10  
Solid wood with 18/10 Stainless Steel legs  
Massif avec arêtes en inox 18/10  
Massivholz, Beine mit Edelstahl Rostfrei 18/10  
Profilen verblendet  
Tablero con angulares en acero inox 18/10

## CHIC

033



034



035



Pannello nobilitato laccato lucido  
Glossy, lacquered, laminated panel  
Panneaux noble laqués  
Glänzend, lackierte, laminierte Paneele  
Tablero chapado lacado brillo

## VIP

036



037



Massello con angolari in massello  
Trolley and solid wood legs  
Panneaux massif  
Trolley und Beine komplett aus Massivholz  
Tablero macizo con angulares macizos

## COLORI

035	033	031 036	032 037	034
Bianco White Blanc Weiss Blanco	Oro Gold Or Gold Oro	Noce Walnut Noyer Walnuss Nuez	Wengè	Nero Black Noir Schwarz Negro

# TROLLEYS

## HAVANA



H cm 87  
cm 50 x 50

H 34 1/4"  
19 3/4" x 19 3/4"

## DELUXE

121



122



Massello con angolari in acciaio inossidabile 18/10  
Solid wood with 18/10 Stainless Steel legs  
Massif avec angle en inox 18/10  
Massivholz, Beine mit Edelstahl Rostfrei 18/10  
Profilen verblendet  
Tablero con angulares en acero inox 18/10

## CHIC

123

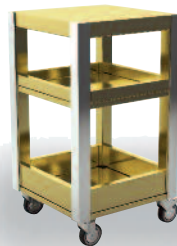

124



125



Pannello nobilitato laccato lucido  
Glossy, lacquered, laminated panel with 18/10 Stainless Steel legs  
Panneaux noble laqués  
Glänzend, lackierte, laminierte Paneele mit Griffen in Edestahl  
Rostfrei 18/10  
Tablero chapado lacado brillo

## VIP

126



127



Massello con angolari in massello  
Trolley and solid wood legs  
Panneaux massif avec angles et hanches massif  
Trolley und Beine komplett aus Massivholz  
Tablero macizo con angulares macizos

## COLORI

125	123	121 126	122 127	124
Bianco White Blanc Weiss Blanco	Oro Gold Or Gold Oro	Noce Walnut Noyer Walnuss Nuez	Wengè	Nero Black Noir Schwarz Negro



## NIZZA



H cm 87  
cm 50 x 50

H 34 1/4"  
19 3/4" x 19 3/4"

## DELUXE

091



092

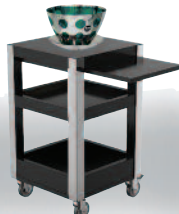

Massello con angolari e maniglioni in acciaio inossidabile 18/10  
Solid wood with 18/10 Stainless Steel handles and legs  
Massif avec arêtes et hanches en inox 18/10  
Massivholz, Beine mit Edelstahl Rostfrei 18/10 Profilen  
verblendet, Griffe 18/10  
Tablero con angulares y asas en acero inox 18/10

## CHIC

093



094



095



Pannello nobilitato laccato lucido  
Glossy, lacquered, laminated panel 18/10 Stainless Steel handles and legs  
Panneaux noble laqués  
Glänzend, lackierte, laminierte Paneele mit Griffen und Beine in Edestahl  
Rostfrei 18/10  
Tablero chapado lacado brillo

Questo carrello comprende un inserto avvitato sul piano ed il relativo secchiello per champagne, art. 599 + art. 589 (colore a vostra scelta).

This trolley includes a screwed insert onto the top and the relative champagne cooler, art. 599 + art. 589 (color to your choice).

Ce chariot comprend un supplément vissé sur l'étage et le relatif seau à champagne, art. 599 + art. 589 (couleur à votre choix).

Dieser Trolley einschl. fixiertem Halter für Weinkühler, art. 599 einschl. Weinkühler mit Einsatz, art. 589 (Farben zu Ihrer Wahl).

Esto carro comprende un legajo atornillado sobre el plan y el relativo cubo por champán, art. 599 + art. 589 (color a vuestra elección).

## COLORI

095	093	091	092	094
Bianco White Blanc Weiss Blanco	Oro Gold Or Gold Oro	Noce Walnut Noyer Walnuss Nuez	Wengè	Nero Black Noir Schwarz Negro

# TROLLEYS

## LAS VEGAS



H cm 83  
cm 104 x 57

H 32 3/4"  
41" x 22 1/2"

H cm 83  
cm 124 x 57

H 32 3/4"  
48 3/4" x 22 1/2"

## DELUXE

051



052



Massello con angolari e maniglioni in acciaio inossidabile 18/10  
Solid wood with 18/10 Stainless Steel handles and legs  
Massif avec arêtes et hanches en inox 18/10  
Massivholz, Beine mit Edelstahl Rostfrei 18/10 Profilen  
verblendet, Griffe 18/10  
Tablero con angulares y asas en acero inox 18/10

## CHIC

053



054



055



Pannello nobilitato laccato lucido  
Glossy, lacquered, laminated panel 18/10 Stainless Steel handles and legs  
Panneaux noble laqués  
Glänzend, lackierte, laminierte Paneele mit Griffen und Beine in Edestahl  
Rostfrei 18/10  
Tablero chapado lacado brillo

## VIP

056



057



Massello con angolari e maniglioni in massello  
Trolley and solid wood handles and legs  
Panneaux massif avec angles et hanches massif  
Trolley und Beine komplett aus Massivholz  
Tablero macizo con angulares y asas macizas

## COLORI

055	053	051 056	052 057	054
Bianco White Blanc Weiss Blanco	Oro Gold Or Gold Oro	Noce Walnut Noyer Walnuss Nuez	Wengè	Nero Black Noir Schwarz Negro



# TROLLEYS

## BARCELONA

Cabinet to accomodate serving pieces



H cm 83  
cm 104 x 57

H 32 3/4"  
41" x 22 1/2"

## DELUXE

071



072



Massello con angolari e maniglioni in acciaio inossidabile 18/10  
Solid wood with 18/10 Stainless Steel handles and legs  
Massif avec angle et hanches en inox 18/10  
Massivholz, Beine mit Edelstahl Rostfrei 18/10 Profilen verblendet, Griffe 18/10  
Tablero con angulares y asas en acero inox 18/10

## VIP

076



077



Massello con angolari e maniglioni in massello  
Trolley and solid wood handles and legs  
Panneaux massif avec angles et hanches massif  
Trolley, Beine und Griffe komplett aus Massivholz  
Tablero macizo con angulares y asas macizas

## COLORI

		071 076	072 077	
Bianco White Blanc Weiss Blanco	Oro Gold Or Gold Oro	Noce Walnut Noyer Walnuss Nuez	Wengè	Nero Black Noir Schwarz Negro

# TROLLEYS

## DUBAI

Full-length cabinet for serving pieces



H cm 83  
cm 124 x 57

H 32 3/4"  
48 3/4" x 22 1/2"

## DELUXE

081

082



Massello con angolari e maniglioni in acciaio inossidabile 18/10  
Solid wood with 18/10 Stainless Steel handles and legs  
Massif avec angle et hanches en inox 18/10  
Massivholz, Beine mit Edelstahl Rostfrei 18/10 Profilen verblendet, Griffe 18/10  
Tablero con angulares y asas en acero inox 18/10

## VIP

086

087



Massello con angolari e maniglioni in massello  
Trolley and solid wood handles and legs  
Panneaux massif avec angles et hanches massif  
Trolley, Beine und Griffe komplett aus Massivholz  
Tablero macizo con angulares y asas macizas

## COLORI

		081 086	082 087	
Bianco White Blanc Weiss Blanco	Oro Gold Or Gold Oro	Noce Walnut Noyer Walnuss Nuez	Wengè	Nero Black Noir Schwarz Negro



# TROLLEYS

## DALLAS



H cm 83  
cm 104 x 57

H 32 3/4"  
41" x 22 1/2"

## DELUXE

041



042



Massello con angolari e maniglioni in acciaio inossidabile 18/10  
Solid wood with 18/10 Stainless Steel handles and legs  
Massif avec arêtes et hanches en inox 18/10  
Massivholz, Beine mit Edelstahl Rostfrei 18/10 Profilen  
verblendet, Griffe 18/10  
Tablero con angulares y asas en acero inox 18/10

## CHIC

043



044



045



Pannello nobilitato laccato lucido  
Glossy, lacquered, laminated panel 18/10 Stainless Steel handles and legs  
Panneaux noble laqués  
Glänzend, lackierte, laminierte Paneele mit Griffen und Beine in Edestahl  
Rostfrei 18/10  
Tablero chapado lacado brillo

## VIP

046



047



Massello con angolari e maniglioni in massello  
Trolley and solid wood handles and legs  
Panneaux massif avec angles et hanches massif  
Trolley und Beine komplett aus Massivholz  
Tablero macizo con angulares y asas macizas

## COLORI

045	043	041 046	042 047	044
Bianco White Blanc Weiss Blanco	Oro Gold Or Gold Oro	Noce Walnut Noyer Walnuss Nuez	Wengè	Nero Black Noir Schwarz Negro

SOLFERINO



H cm 83  
cm 104 x 57

H 32 3/4"  
41" x 22 1/2"

DELUXE

221

222



Massello con maniglioni in acciaio inossidabile 18/10  
Solid wood with 18/10 Stainless Steel legs  
Massif avec hanches en inox 18/10  
Massivholz mit Griffen in Edelstahl Rostfrei 18/10  
Tablero macizo con asa en acero inox 18/10

CHIC

223

224

225



Pannello nobilitato laccato lucido con maniglioni in acciaio inossidabile 18/10  
Glossy, lacquered, laminated panel with handles in 18/10 Stainless Steel  
Panneaux noble laqués et hanches en inox 18/10  
Glänzend, lackierte, laminierte Paneele mit Griffen in Edelstahl Rostfrei 18/10  
Tablero chapado lacado brillo con asa en acero inox 18/10

COLORI

225	223	221	222	224
Bianco White Blanc Weiss Blanco	Oro Gold Or Gold Oro	Noce Walnut Noyer Walnuss Nuez	Wengè	Nero Black Noir Schwarz Negro



# TROLLEYS

## MIAMI



H cm 82  
cm 80 x 91

H 32 1/4"  
31 1/2" x 35 7/8"

## DELUXE

106



107



Massello con angolari in acciaio inossidabile 18/10  
Solid wood with 18/10 Stainless Steel legs  
Massif avec angle en inox 18/10  
Massivholz, Beine mit Edelstahl Rostfrei 18/10  
Profilen verblendet  
Tablero con angulares en acero inox 18/10

## CHIC

103



104



105



Pannello nobilitato laccato lucido  
Glossy, lacquered, laminated panel with 18/10 Stainless Steel legs  
Panneaux noble laqués  
Glänzend, lackierte, laminierte Paneele mit Griffen in Edestahl  
Rostfrei 18/10  
Tablero chapado lacado brillo

## VIP

101



102



Massello con angolari in massello  
Trolley and solid wood legs  
Panneaux massif avec angles et hanches massif  
Trolley und Beine komplett aus Massivholz  
Tablero macizo con angulares macizos

## COLORI

105	103	101 106	102 107	104
Bianco White Blanc Weiss Blanco	Oro Gold Or Gold Oro	Noce Walnut Noyer Walnuss Nuez	Wengè	Nero Black Noir Schwarz Negro



## MANIGLIA

Maniglione a scomparsa, regolabile in altezza, per la corretta postura della schiena durante la movimentazione.

## HANDLE

The foldaway handle can be ergonomically adjusted to the height of the user during transport.

## POIGNÉE

Poignée disparible, réglable en hauteur, pour la posture correcte du dos pendant le mouvements.

## SCHIEBEGRIFF

Der einklappbare Schiebegriff kann ergonomisch exakt auf die passende Höhe des Fahrers eingestellt werden, die er zum jeweiligen Transport benötigt.

## AGARRADOR

Agarrador abatible, ajustable en altura, para una correcta postura de la espalda durante el uso.



## HOT BOX

Contenitore Hot Box elettrico a 4 scomparti, con termostato regolabile fino a 90° C. Diametro massimo dei piatti inseribili: 31 cm.

## HOT BOX

Electric Hot Box compartment, 4 compartments with adjustable thermostat up to 194° F. Maximum inner dimension:: 12 1/2".

## HOT BOX

Récipient Hot Box électrique aux 4 compartiments, avec thermostat réglable jusqu'à 90° C. Maximum diamètre des plats insertables: 31 cms.

## HOT BOX

Elektrisch betriebene HOT BOX mit 4 Abteilungen, mit jeweils Nutzfläche bis zu 31 cm Durchmesser. Die HOT BOX ist ausgestattet mit einem regelbaren Thermostat bis zu 90° C.

## HOT BOX

Contenedor eléctrico de 4 compartimentos, con termostato ajustable a 90° C. Diámetro máximo de los platos insertables: 31 cm.



## PIANO SUPERIORE ESTENSIBILE

Piano superiore estensibile "a tavolino", massima estensione cm. 92 x 80

## EXTENDABLE UPPER SURFACE

Upper surface can be extended up to 36 1/2" x 31 1/2"

## PLAT SUPÉRIEUR EXTENSIBLE

Plat supérieur extensible, meilleure étendue cm. 92 x 80.

## AUSKLAPPBARE TISCHFLÄCHE

Die Tischfläche kann durch Ausklappen vergrößert werden auf das Mass von 92 x 80 cm.

## PLANO SUPERIOR EXTENSIBLE

Plano superior extensible, medida total extendida 92 x 80 cm.





## CASSETTI

Cassetti portaposate, portatovaglie, scomparti portabottiglie e bicchieri.

## DRAWERS

Drawers available for cutlery, table cloths and napkins. Compartments for wine bottles, glasses and stemware are also available.

## TIROIRS

Tiroirs portecouverts, portenappes, compartiments portebouteilles et verres.

## SCHUBLADEN

Es sind Schubladen erhältlich für Besteck, Tischwäsche und Servietten. Fächer für Weinflaschen, Becher und Stielgläser sind ebenfalls erhältlich.

## CAJONES

Cajones para cubiertos, servilletas, manteles, y compartimentos para botellas y vasos.



## CARATTERISTICHE

Alta resistenza, massima maneggevolezza, ruote maggiorate ed anti-statiche.

## FEATURES

Durable oversized casters feature maximum maneuverability with non-tracking and non-conductive rubber wheels.

## CARACTÉRISTIQUES

Haute résistance, meilleure maniabilité, roues augmentées et antistatiques.

## BESONDERHEITEN

Die groß-dimensionierten, robusten Rollen aus antistatischem Gummi-Material erlauben eine hochgrade Beweglichkeit, selbst bei der Überwindung schwierigster Hindernisse und unterschiedlichsten Bödenbelägen.

## CARACTERÍSTICAS

Alta resistencia, máxima manejabilidad, ruedas grandes y antiestáticas.

110



## HOT BOX

Contenitore Hot Box elettrico a 4 scomparti, con termostato regolabile fino a 90° C. Diametro massimo dei piatti inseribili: 31 cm.

## HOT BOX

Electric Hot Box compartment, 4 compartments with adjustable thermostat up to 194° F. Maximum inner dimension:: 12 1/2".

## HOT BOX

Réceptacle Hot Box électrique aux 4 compartiments, avec thermostat réglable jusqu'à 90° C. Maximum diamètre des plats insertables: 31 cms.

## HOT BOX

Elektrisch betriebene HOT BOX mit 4 Abteilungen, mit jeweils Nutzfläche bis zu 31 cm Durchmesser. Die HOT BOX ist ausgestattet mit einem regelbaren Thermostat bis zu 90° C.

## HOT BOX

Contenedor eléctrico de 4 compartimentos, con termostato ajustable a 90° C. Diámetro máximo de los platos insertables: 31 cm.

## DELUXE - VIP



H cm 5,5

H 21/4"

Tutte le versioni Deluxe e Vip hanno la struttura in massello e il piano superiore in massello listellare. Colori optional: faggio, ciliegio, rovere e mogano.

All the wood components for the Deluxe and VIP versions are made from solid wood and the workspace top is made from heavy duty solid Block Wood Available colors: Beachwood, Cherry, Oak and Mahogany

Toutes les versions Deluxe et Vip ont la structure en massif et le plan supérieur en massif. Couleurs facultatif: Hêtre, Cerise, Chêne et Acajou.

Alle Ausführungen für die Deluxe- und VIP-Versionen sind hergestellt aus massivem Holz und die oberen Arbeitsbereiche aus strapazierfähigem, solidem Blockholz  
Verfügbare Farben: Buche, Kirsche, Eiche und Mahagoni

Todas las versiones "Deluxe" y "Vip" tienen la estructura en tablero macizo y el plano superior en tablero macizo listelar  
Colores disponibles: Haya, Cerezo, Roble y Caoba

## CHIC



H cm 4

H 15/8"

La versione Chic è interamente in nobilitato laccato lucido, con il piano superiore di alto spessore. The Chic version has an entirely glossy, lacquered, laminate faced finish with a heavy duty workspace top. La version Chic est tout à fait de panneaux noble laqués, avec le plan supérieur de grande épaisseur. Die Chic-Versionen haben ein gänzlich glänzendes, lackiertes, laminiertes Finish mit einem strapazierfähigen oberen Arbeits-Top. La versión "Chic" es enteramente chapado lacado brillo, y con el plano superior de alto espesor.

## RICAMBI

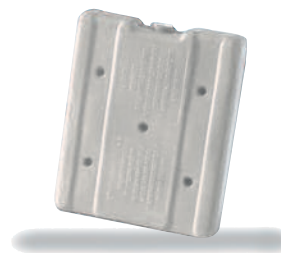

cm 15,5 x 7,5  
H cm 2

6" x 27/8"  
H 1"

Piastre eutettiche senza evaporatore, disponibili per tutte le cupole: congelate a -21°C, durano fino a tre ore. Eutectic cooling plates without evaporator are available for all of the roll-top covers. Refrigerated to -5,8°F, they will keep cool for approximately 3 hours. Bacs eutectiques sans evaporateur, sont disponibles pour toutes les lavallières: réfrigérée à -21° C, ils durent jusqu'à trois heures. Eutektische Kühlplatten ohne Verdampfer, für alle Roll-top Aufsatz erhältlich: vor dem Gebrauch, im Gefrierschrank mit -21°C abkühlen; damit verfügen Sie über 3 Stunden Kühlleistung. Planchas eutecticas sin vaporizador, disponibles para todas las cúpulas: congeláis a -21°C, duran hasta tres horas.

## 800



H cm 29  
cm 11 x 11

H 11 3/4"  
4 1/2" x 4 1/2"

Campionario colore per sala esposizione  
Colori disponibili: noce, wengè, bianco, nero e oro.

Color Displayer for show room  
Available colors: walnut, wenge, gold, black and white.

Couleur Displayer pour show room  
Couleurs disponibles: Noyer, Wenge, Blanc, Noir et Or.

Farben Displayer für Show-Room  
Erhältliche Farben: Walnuss, Wenge, Weiss, Schwarz und Gold.

Color Displayer para sala de exposiciones  
Colores disponibles: Nogal, Wenge, Blanco, Negro y Oro.

## ACCESSORI

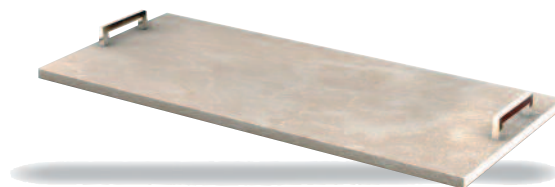

cm 83 x 36  
H cm 2

32 3/4" x 14 1/4"  
H 1"

Piano in marmo granito, perfettamente levigato e lucidato. Perfectly ground and polished granite marble top surface. Plan en marbre granulé, parfaitement lissé et poli. Polierte Granit-Marmor-Platte mit perfekt glatt geschliffener Oberfläche  
Plano en mármol granito, perfectamente pulido.



## PARIS

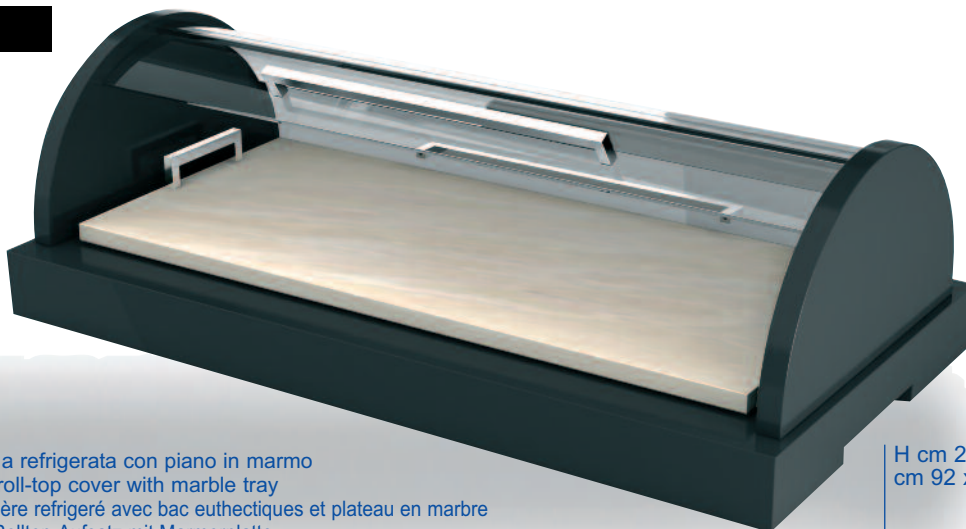

Cupola refrigerata con piano in marmo  
Cool roll-top cover with marble tray  
Lavallière réfrigéré avec bac eutectiques et plateau en marbre  
Kühl-Rolltop-Aufsatz mit Marmorplatte  
Cúpula refrigerada con plano en mármol

H cm 28,5  
cm 92 x 47

H 11 $\frac{1}{2}$ "  
36 $\frac{1}{2}$ " x 18 $\frac{1}{2}$ "

## DELUXE

161

162



Massello  
Solid wood  
Massif  
Massivholz  
Tablero macizo

## CHIC

163

164

165



Pannello nobilitato laccato lucido  
Glossy, lacquered, laminated panel  
Panneaux noble laqués  
Glänzend, lackierte, laminierte Paneele  
Tablero chapado lacado brillo

## COLORI



- 3 Piastre eutettiche senza evaporatore sono già inserite nella cupola refrigerata
- 3 Eutectic cooling plates without evaporator are already inserted into the roll-top cover
- 3 Bacs eutectiques sans évaporateur sont déjà insérés dans la lavallière
- 3 Bereits eingelegte Kühlaccus gehören mit zum Lieferumfang
- 3 Planchas eutecticas sin vaporizador son ya insertadas en la cúpula refrigerada

165	163	161	162	164
Bianco White Blanc Weiss Blanco	Oro Gold Or Gold Oro	Noce Walnut Noyer Walnuss Nuez	Wengè	Nero Black Noir Schwarz Negro

## WIEN

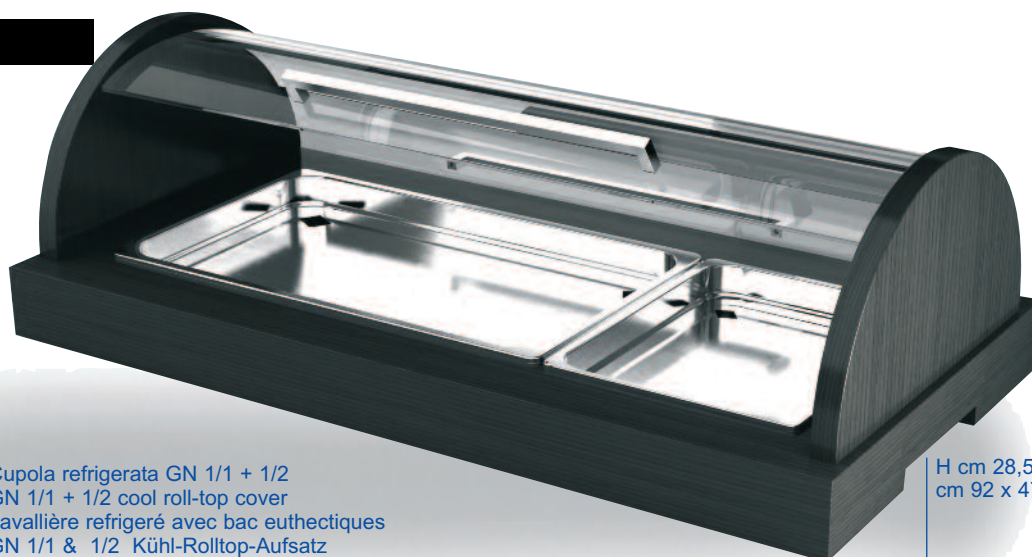

Cupola refrigerata GN 1/1 + 1/2  
GN 1/1 + 1/2 cool roll-top cover  
Lavallière refrigeré avec bac eutectiques  
GN 1/1 & 1/2 Kühl-Rolltop-Aufsatz  
Cúpula refrigerada GN 1/1 -1/2

H cm 28,5  
cm 92 x 47

H 11 1/4"  
36 1/4" x 18 1/2"

## DELUXE

141

142



Massello  
Solid wood  
Massif  
Massivholz  
Tablero macizo

## CHIC

143

144

145

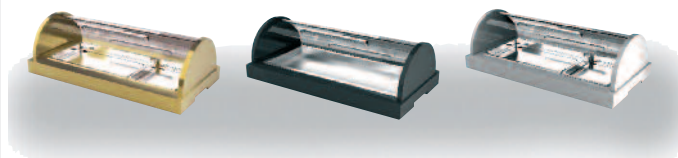

Pannello nobilitato laccato lucido  
Glossy, lacquered, laminated panel  
Panneaux noble laqués  
Glänzend, lackierte, laminierte Paneele  
Tablero chapado lacado brillo

## COLORI



- 3 Piastre eutettiche senza evaporatore sono già inserite nella cupola refrigerata
- 3 Eutectic cooling plates without evaporator are already inserted into the roll-top cover
- 3 Bacs eutectiques sans évaporateur sont déjà insérés dans la lavallière
- 3 Bereits eingelegte Kühlaccus gehören mit zum Lieferumfang
- 3 Planchas eutecticas sin vaporizador son ya insertadas en la cúpula refrigerada

145	143	141	142	144
Bianco White Blanc Weiss Blanco	Oro Gold Or Gold Oro	Noce Walnut Noyer Walnuss Nuez	Wengè	Nero Black Noir Schwarz Negro



## GRUYERE



Cupola refrigerata GN 1/1  
GN 1/1 cool roll-top cover  
Lavallière réfrigéré avec bac eutectiques  
GN 1/1 Kühl-Rolltop-Aufsatz  
Cúpula refrigerada GN 1/1

H cm 29  
cm 63 x 47

H 11 7/8"  
24 7/8" x 18 1/2"

## DELUXE

261



262



Massello  
Solid wood  
Massif  
Massivholz  
Tablero macizo

## CHIC

263



264



265



Pannello nobilitato laccato lucido  
Glossy, lacquered, laminated panel  
Panneaux noble laqués  
Glänzend, lackierte, laminierte Paneele  
Tablero chapado lacado brillo

## COLORI



- 2 Piastre eutettiche senza evaporatore sono già inserite nella cupola refrigerata
- 2 Eutectic cooling plates without evaporator are already inserted into the roll-top cover
- 2 Bacs eutectiques sans évaporateur sont déjà insérés dans la lavallière
- 2 Bereits eingelegte Kühlaccus gehören mit zum Lieferumfang
- 2 Planchas eutecticas sin vaporizador son ya insertadas en la cúpula refrigerada

265	263	261	262	264
Bianco White Blanc Weiss Blanco	Oro Gold Or Gold Oro	Noce Walnut Noyer Walnuss Nuez	Wengè	Nero Black Noir Schwarz Negro

## PRAGA



Cupola refrigerata GN 1/1  
GN 1/1 cool roll-top cover  
Lavallière réfrigéré avec bac eutectiques  
GN 1/1 Kühl-Rolltop-Aufsatz  
Cúpula refrigerada GN 1/1

H cm 29  
cm 63 x 47

H 11 7/8"  
24 7/8" x 18 1/2"

## DELUXE

281

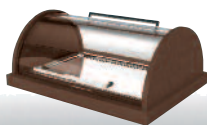

282

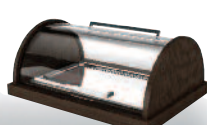

Massello  
Solid wood  
Massif  
Massivholz  
Tablero macizo

## CHIC

283

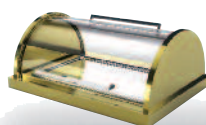

284



285

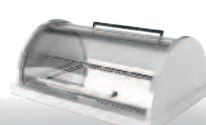

Pannello nobilitato laccato lucido  
Glossy, lacquered, laminated panel  
Panneaux noble laqués  
Glänzend, lackierte, laminierte Paneele  
Tablero chapado lacado brillo

## COLORI



- 2 Piastre eutettiche senza evaporatore sono già inserite nella cupola refrigerata
- 2 Eutectic cooling plates without evaporator are already inserted into the roll-top cover
- 2 Bacs eutectiques sans évaporateur sont déjà insérés dans la lavallière
- 2 Bereits eingelegte Kühlelaccus gehören mit zum Lieferumfang
- 2 Planchas eutecticas sin vaporizador son ya insertadas en la cúpula refrigerada

285	283	281	282	284
Bianco White Blanc Weiss Blanco	Oro Gold Or Gold Oro	Noce Walnut Noyer Walnuss Nuez	Wengè	Nero Black Noir Schwarz Negro



## SPARTA



Cúpola refrigerata a 2 piani GN 1/1  
 GN 1/1 cool roll-top cover 2 layers  
 Lavallière réfrigéré 2 étages avec bac eutectiques  
 GN 1/1 Kühl-Rolltop-Aufsatz 2-stufig  
 Cúpula refrigerada 2 pisos GN 1/1

H cm 58  
 cm 63 x 47

H 22 7/8"  
 24 7/8" x 18 1/2"

## DELUXE

271



272



Massello  
 Solid wood  
 Massif  
 Massivholz  
 Tablero macizo

## CHIC

273



274



275



Pannello nobilitato laccato lucido  
 Glossy, lacquered, laminated panel  
 Panneaux noble laqués  
 Glänzend, lackierte, laminierte Paneele  
 Tablero chapado lacado brillo

## COLORI



- 4 Piastre eutettiche senza evaporatore sono già inserite nella cúpola refrigerata
- 4 Eutectic cooling plates without evaporator are already inserted into the roll-top cover
- 4 Bacs eutectiques sans évaporateur sont déjà insérés dans la lavallière
- 4 Bereits eingelegte Kühlaccus gehören mit zum Lieferumfang
- 4 Planchas eutecticas sin vaporizador son ya insertadas en la cúpula refrigerada

275	273	271	272	274
Bianco White Blanc Weiss Blanco	Oro Gold Or Gold Oro	Noce Walnut Noyer Walnuss Nuez	Wengè	Nero Black Noir Schwarz Negro

# TROLLEYS

## ATENE



Cupola refrigerata a 2 piani GN 1/1  
 GN 1/1 cool roll-top cover 2 layers  
 Lavallière réfrigéré 2 étages avec bac eutectiques  
 GN 1/1 Kühl-Rolltop-Aufsatz 2-stufig  
 Cúpula refrigerada 2 pisos GN 1/1

H cm 58  
 cm 63 x 47

H 22 7/8"  
 24 7/8" x 18 1/2"

## DELUXE

151



152



Massello  
 Solid wood  
 Massif  
 Massivholz  
 Tablero macizo

## CHIC

153



154



155



Pannello nobilitato laccato lucido  
 Glossy, lacquered, laminated panel  
 Panneaux noble laqués  
 Glänzend, lackierte, laminierte Paneele  
 Tablero chapado lacado brillo

## COLORI



- 4 Piastre eutettiche senza evaporatore sono già inserite nella cupola refrigerata
- 4 Eutectic cooling plates without evaporator are already inserted into the roll-top cover
- 4 Bacs eutectiques sans évaporateur sont déjà insérés dans la lavallière
- 4 Bereits eingelegte Kühlaccus gehören mit zum Lieferumfang
- 4 Planchas eutecticas sin vaporizador son ya insertadas en la cúpula refrigerada

155	153	151	152	154
Bianco White Blanc Weiss Blanco	Oro Gold Or Gold Oro	Noce Walnut Noyer Walnuss Nuez	Wengè	Nero Black Noir Schwarz Negro



RADICE OVALE



NATURAL

WHITE

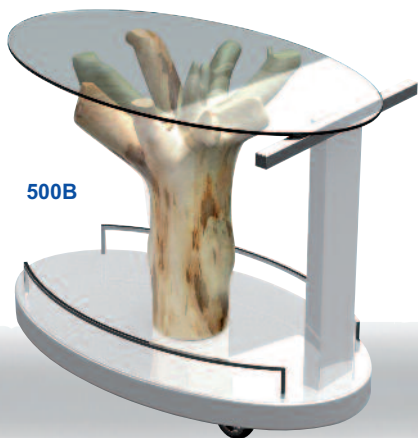

500B

NATURAL

BLACK

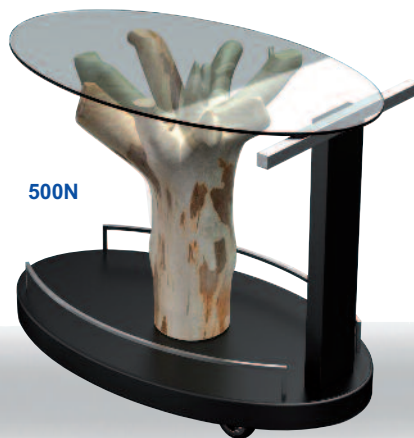

500N

Ogni carrello è un pezzo unico: la radice proviene dai rigogliosi boschi del Nord Italia, raccolta e lavorata dai nostri artigiani dopo la caduta spontanea dell'albero a terra. I cristalli sono temperati, spessore 10 mm.

Each trolley is unique: the root comes from the lush forests of Northern Italy, and is collected and processed by our craftsmen after the tree's natural fall. The crystals are 10mm thick and tempered.

Chaque table est unique: la racine provient des forêts luxuriantes du nord de l'Italie, récoltées et traitées par nos artisans après la chute spontanée de l'arbre sur le sol. Les cristaux sont tempérés, épaisseur 10 mm.





BLACK



504

Jeder Trolley ist einzigartig: die Wurzel stammt aus den dichten Wäldern von Nord-Italien. Nachdem der Baum auf natürliche Weise zu Fall kam, werden die einzelnen Wurzelstücke von unseren Handwerkern eingesammelt und verarbeitet. Die Glasplatte ist aus Spezialglas mit 10mm Dicke.

WHITE

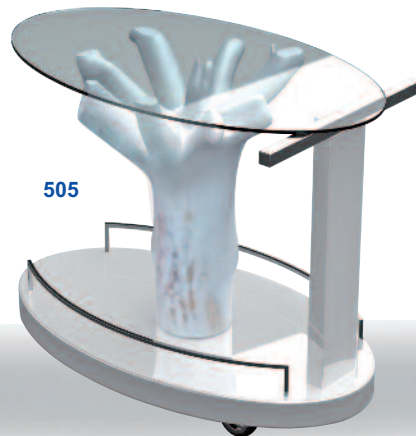

505

Cada carro es único: la raíz viene de los exuberantes bosques del norte de Italia, producidas y elaboradas por nuestros artesanos después de la caída espontánea del árbol al suelo. Los cristales son templados, espesor 10 mm.

H cm 83  
cm 100 x 57

H 32 3/4"  
39 1/2" x 22 1/2"



## RADICE RETTANGOLARE



NATURAL

WHITE

510B



NATURAL

BLACK

510N



Ogni carrello è un pezzo unico: la radice proviene dai rigogliosi boschi del Nord Italia, raccolta e lavorata dai nostri artigiani dopo la caduta spontanea dell'albero a terra. I cristalli sono temperati, spessore 10 mm.

Each trolley is unique: the root comes from the lush forests of Northern Italy, and is collected and processed by our craftsmen after the tree's natural fall. The crystals are 10mm thick and tempered.

Chaque table est unique: la racine provient des forêts luxuriantes du nord de l'Italie, récoltées et traitées par nos artisans après la chute spontanée de l'arbre sur le sol. Les cristaux sont tempérés, épaisseur 10 mm.





BLACK



514

WHITE

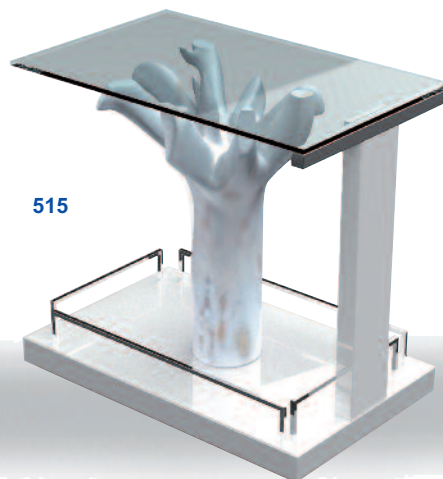

515

Jeder Trolley ist einzigartig: die Wurzel stammt aus den dichten Wäldern von Nord-Italien. Nachdem der Baum auf natürliche Weise zu Fall kam, werden die einzelnen Wurzelstücke von unseren Handwerkern eingesammelt und verarbeitet. Die Glasplatte ist aus Spezialglas mit 10mm Dicke.

Cada carro es único: la raíz viene de los exuberantes bosques del norte de Italia, producidas y elaboradas por nuestros artesanos después de la caída espontánea del árbol al suelo. Los cristales son templados, espesor 10 mm.

H cm 80  
cm 80 x 50

H 31 1/2"  
31 1/2" x 19 3/4"



## RADICE QUADRA



## NATURAL

WHITE

520B

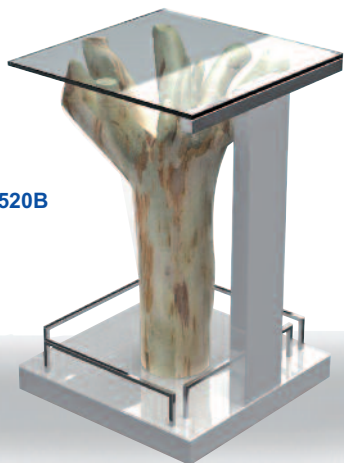

## NATURAL

BLACK

520N

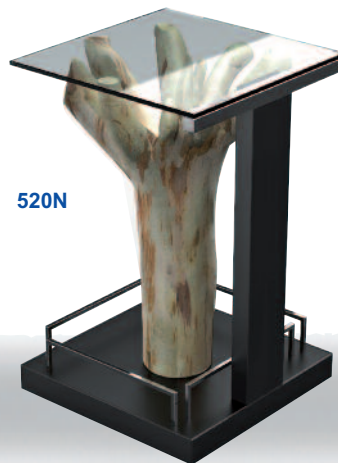

Ogni carrello è un pezzo unico: la radice proviene dai rigogliosi boschi del Nord Italia, raccolta e lavorata dai nostri artigiani dopo la caduta spontanea dell'albero a terra. I cristalli sono temperati, spessore 10 mm.

Each trolley is unique: the root comes from the lush forests of Northern Italy, and is collected and processed by our craftsmen after the tree's natural fall. The crystals are 10mm thick and tempered.

Chaque table est unique: la racine provient des forêts luxuriantes du nord de l'Italie, récoltées et traitées par nos artisans après la chute spontanée de l'arbre sur le sol. Les cristaux sont tempérés, épaisseur 10 mm.

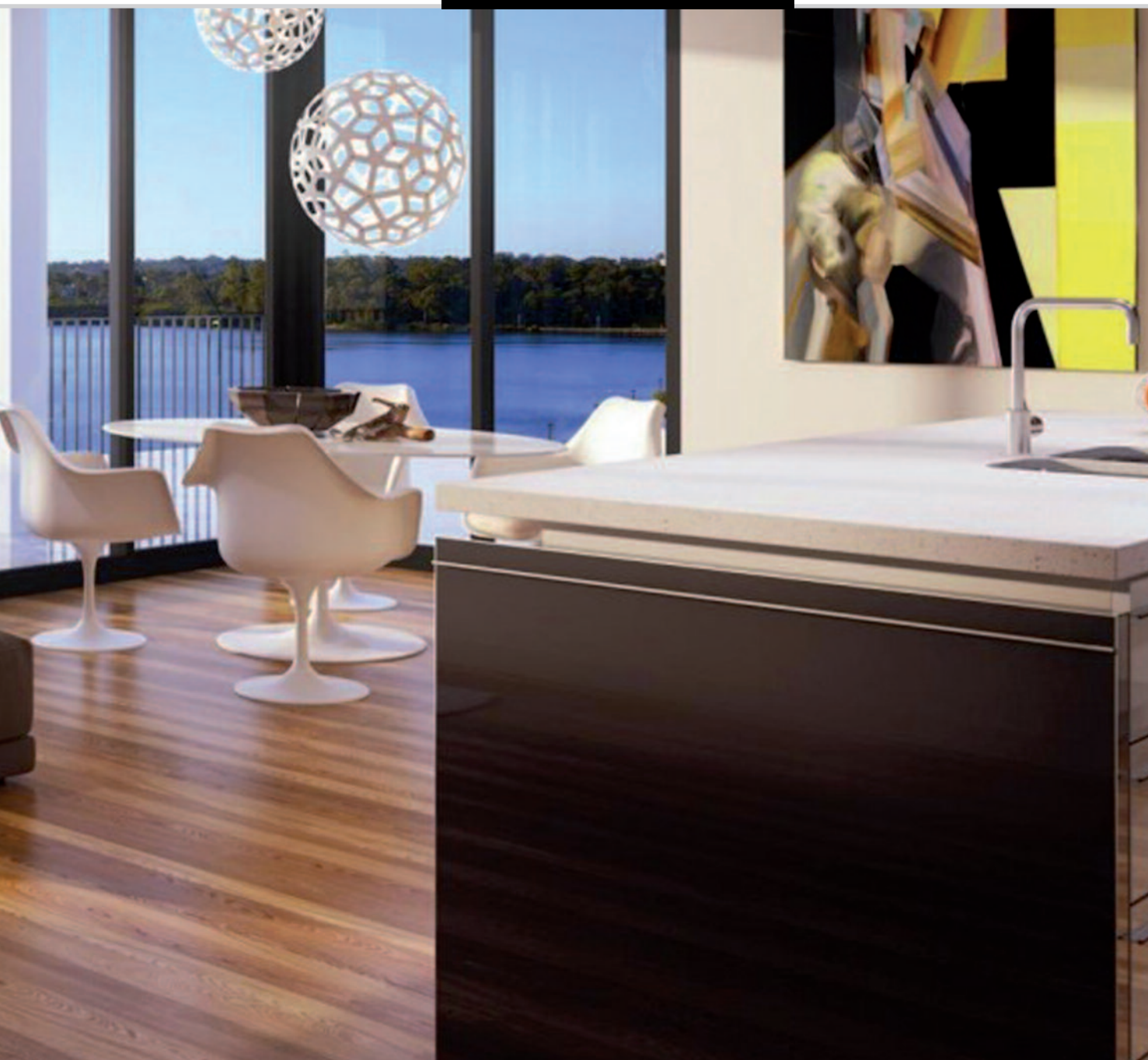

BLACK

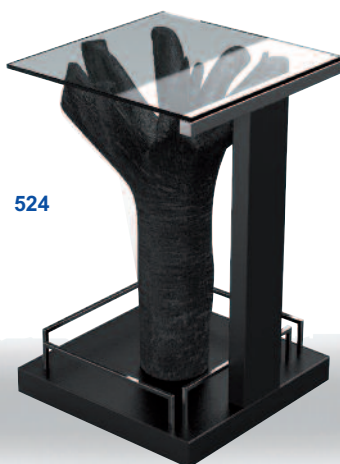

524

WHITE

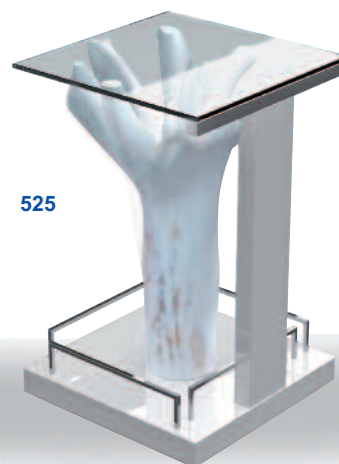

525

Jeder Trolley ist einzigartig: die Wurzel stammt aus den dichten Wäldern von Nord-Italien. Nachdem der Baum auf natürliche Weise zu Fall kam, werden die einzelnen Wurzelstücke von unseren Handwerkern eingesammelt und verarbeitet. Die Glasplatte ist aus Spezialglas mit 10mm Dicke.

Cada carro es único: la raíz viene de los exuberantes bosques del norte de Italia, producidas y elaboradas por nuestros artesanos después de la caída espontánea del árbol al suelo. Los cristales son templados, espesor 10 mm.

H cm 85  
cm 50 x 50

H 33 3/8"  
19 3/4" x 19 3/4"



# TROLLEYS

TEVERE



H cm 80  
cm 80 x 40

H 31 1/2"  
31 1/2" x 15 3/4"

302



Pannello nobilitato in essenza  
Laminated panel  
Panneaux noble  
Lackierte Paneele  
Tablero lacado

308



Pannello nobilitato in essenza  
Laminated panel  
Panneaux noble  
Lackierte Paneele  
Tablero lacado

309



Pannello nobilitato in essenza  
Laminated panel  
Panneaux noble  
Lackierte Paneele  
Tablero lacado

COLORI

302	308	309
Wengè	Bronzo Copper Cuivre Kupfer Cobre	Castagno chiaro Light chestnut Châtain clair Heile Kastanie Castaño claro

# TROLLEYS

## MISSISSIPPI



H cm 85  
cm 98 x 57

H 33 1/2"  
38 5/8" x 22 3/8"

332



Pannello nobilitato in essenza  
Laminated panel  
Panneaux noble  
Lackierte Paneele  
Tablero lacado

338



Pannello nobilitato in essenza  
Laminated panel  
Panneaux noble  
Lackierte Paneele  
Tablero lacado

339



Pannello nobilitato in essenza  
Laminated panel  
Panneaux noble  
Lackierte Paneele  
Tablero lacado

## COLORI

332	338	339
Wengè	Bronzo Copper Cuivre Kupfer Cobre	Castagno chiaro Light chestnut Châtain clair Heile Kastanie Castaño claro



# TROLLEYS

**RENO**



H cm 85  
cm 50 x 50

H 33 1/2"  
19 3/4" x 19 3/4"

**322**



Pannello nobilitato in essenza  
Laminated panel  
Panneaux noble  
Lackierte Paneele  
Tablero lacado

**328**



Pannello nobilitato in essenza  
Laminated panel  
Panneaux noble  
Lackierte Paneele  
Tablero lacado

**329**



Pannello nobilitato in essenza  
Laminated panel  
Panneaux noble  
Lackierte Paneele  
Tablero lacado

**COLORI**

322	328	329
Wengè	Bronzo Copper Cuivre Kupfer Cobre	Castagno chiaro Light chestnut Châtain clair Heile Kastanie Castaño claro

**Alta resistenza al graffio per il normale utilizzo**

High resistance to scratch for normal use  
 Hautes résistance aux griffures  
 Kratzfest bei normalem Gebrauch.  
 Alta resistencia a las rayas resultantes del uso normal

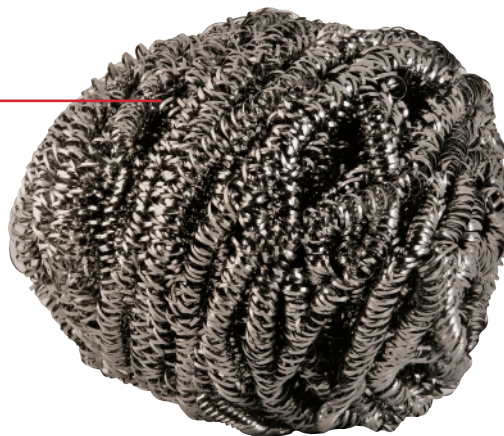

**Idrorepellente non cambia colore a contatto con liquidi e cibi**

Hydro repellant, it doesn't change colour when in contact with liquids or foods.  
 Matière ne subissant aucunes agressions exterieurs, liquide et autres.....  
 Wasserfest, keine Farbveränderung bei Kontakt mit Flüssigkeiten oder Esswaren.  
 Repelente al agua, no cambia de color al entrar en contacto con líquidos y alimentos.

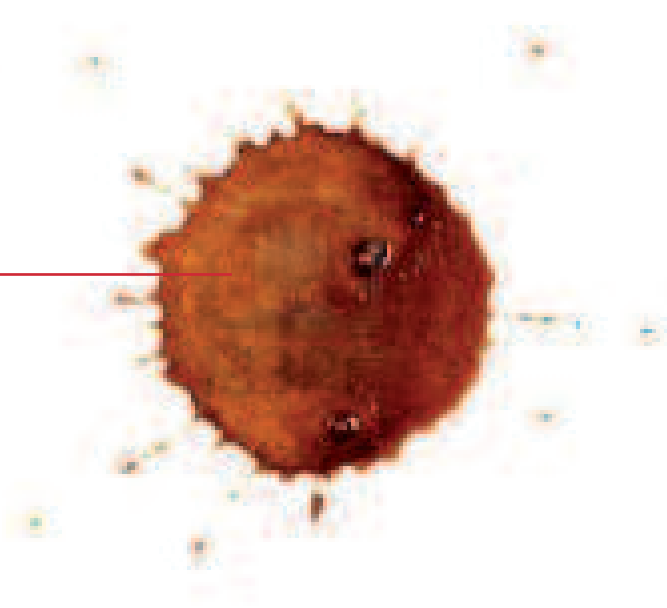

**Ruote speciali a grandezza maggiorata, fascia in gomma antistatica e antitraccia.  
 Ruote e struttura potenziate ad alta portata**

The oversized wheels are antistatic, won't leave marks.  
 Wheels and enhanced high-range structure.  
 Roulettes surdimensionnées spéciales, avec bande en caoutchouc synthétique conducteur antitrace.  
 Roues et roulements adaptées en fonction du poids de la table roulante.  
 Besonders grossdimensionierte Rollen mit antistatischen Gummireifen, die keinen Abrieb hinterlassen.  
 Die Rollen und das Gefüge verstärkte sind, um grössere Fähigkeit zu tragen.  
 Ruedas especiales de mayor tamaño, con cinta de goma antistatica y antihuellas.  
 Ruedas y estructura mejoradas de alta capacidad.

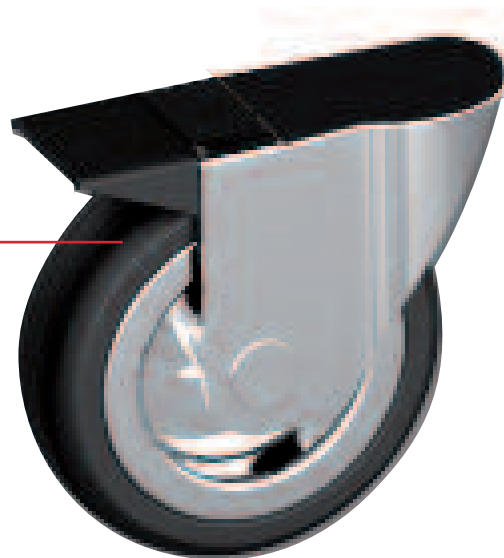





INDICE

INDEX

INDEX

ALPHABETISCHES REGISTER

INDICE

NUMERI

RESTAURANT

HOTEL



# Indice

## A B

	Pag
Agitatore	213
Agitatore Boston	213
Allacciatoavaglioli	141,149,235
Alzata dolci	79,82,139,156
Alzata pane	96
Alzata pesce crudo	85,93,118,119,120,143
Alzata portafrutta	78,79,82,93,139,156
Alzata portapiatti	83
Alzata torta	80,92,138
Ampolla	81,108,158,159,178,232
Antipastiera	142,143,148,151,153,155 180,231,236
Appoggia chop sticks	67
Appoggia posate	73,197
Apriostriche	120
Bicchiere	106,192,247,251,254
Bistecchiera	243
Bottiglia	108
Braciere con griglia	115,178
Bricco	203
Brocca per acqua	206
Bugia	89,144

## C

Caffettiera	82,145,201,202,205,206 207
Caffettiera termica	201,202,205
Candelabro	83,89,144,199
Caraffa per bibite	195,250
Caraffa termica	201,202
Carrello portavivande	261 <> 272,280 <> 288
Casseruola	241,243
Cavatappi	174
Centrotavola	107,118,119,121,138,188 236
Cestino	96,97,101,102,103,104 105,107,118,119,123,138 152,153,155,157,172,188 231,235,247
Cestino portabonbon	155
Cestino portacondimenti	129,143,152,169,172
Cestino portafrutta	107,139,152,153,155,157
Cestino portapanne	80,96,138,149,151,152 155,235
Cestino portatovaglioli	96,208
Cesto porta agrumi	96,97,104,155,188,223 231,235
Chafing dish	196,198
Champagnera	215,225,228
Chillcup	81,98
Chop sticks	67
Ciambella termica	181
Ciotola in acciaio	78,97,138,169
Ciotola in legno	123
Ciotola in policarbonato	123,223,248,249
Ciotola in polipropilene	254
Cloche	83,86,163,168,173
Coffee Design Kit	211
Coffee Urn	197
Colino da cocktail	174
Colonna portasecchiello	84,94,95,105,123,135,216 217,218,219,220,221,223
Colonna portasigari	106
Coltelli	7 <> 43,71,72,73,120,179
Contenitore per bibite	195
Coperchio	86,108,161,162,166
Coperchio per legumiera e zuppiera	86,166
Coperchio per piatto ovale	162
Coppa burro	81,98
Coppa caviale	81,98
Coppa cocktail e scampi	81,98
Coppa con piede	80,85,89,213
Coppa crema/potage	166
Coppa intermezzo	170
Coppa in vetro	80,108
Coppa lavadita	168
Coppa Martini	170,251
Coppa multiservizio	80,138
Coppa per champagne	85,95,104
Coppa per gelato e/o macedonia	98,172,251
Coppa per pinzimonio	181

## Pag

Coppa per punch	89,213
Coppa vichyssoise	98,166
Copripiatto	161,162,163
Cremiera	106,180,209
Cubetto luminoso LED	229
Cucchiaino da cocktail	7 <> 43
Cucchiaino per cappuccino	209
Cucchiaino per caviale	174
Cucchiaino sale	73,192
Cucchiaino agitatore	73,214
Cucchiaino monoporzione	69
Cucchiaino per bibita	7 <> 43
Cucchiaino per insalata	7 <> 43,197
Cucchiaino per parmigiano	7 <> 43
Cucchiaino per risotto	69,73,197,257
Cucchiaino per salsa	7 <> 43,257
Cucchiaino servire	7 <> 43,69,73,197
Culla porta champagne	199
Cupola refrigerata	274 <> 279

## D E F

Distributore di latte	197
Distributore di succo di frutta	197
Dosatore sale e pepe	106
Dosatore	213
Espositore per buffet	188
Finger food	110 <> 115
Forchetta aragosta	73
Forchetta monoporzione	73,192
Forchetta per bistecca	71,179
Forchetta per insalata	7 <> 43,69,197
Forchetta per lumache	73
Forchetta servire	7 <> 43,69,197
Forchetta servire pesce	7 <> 43,69,257
Forchettina ostriche	7 <> 43
Forchettina cocktail	73,192
Forchettone	7 <> 43,69,197
Formaggiaria	81,99,108,125,129,142 149,151,152,153,155,159 168,232,236
Fruttiera	139,152,153,155,157

## G I L

Glacette termica	218
Golf club mixer spoon	73,214
Grattugia	174
Gueridon d'appoggio	222
Infusiera	195
Insalatiera	78,97,108,248,250
Inserito per finger food	115,184
Lasagnera	142,148,181
Lattiera	82,145,201,202,205,206 207
Legatovaglioli	141,149,235
Legumiera	86,166
Legumiera escoffier	162

## M N O

Macine	175
Menage	87,99,108,125,129,142 149,151,152,153,155,158 159,232,236
Mestolo	7 <> 43,69,213
Mini burriera	87,99
Mini casseruola	241
Mini forchetta	73,192
Mini spoon	73,192
Mini vaporiera	115
Mini vassoio	113,188
Misurino cocktail	213
Molla per asparagi	167
Molla per arrosto e verdure	167
Molla per dolci	167
Molla per frutta	167
Molla per ghiaccio	167,214
Molla per lumache	73,167,168
Molla per pane	167
Molla per spaghetti	167
Molla per zucchero	167,203
Mug	249
Numero da tavola	85,97,144,170,173

# Indice

	Pag
Oliera	87,99,108,125,129,142 149,151,152,153,155,158 159,232,236
<b>P Q R</b>	
Padella	241,243
Pala per torta	7 <> 43 69,197
Pentola	241,243
Petit marmite	196,198
Piano milleusi	232
Piastra ad induzione ed elettrica	196
Piastra eutettica	274 < > 279
Piattino per burro	154,157
Piattino per lumache	168
Piattino per mug	249
Piattino per pane	101,157,232
Piattino porta monete	137,213
Piattino sottocoppa	98
Piatto da presentazione	101,103,124,128,140,147 153,154,156,171,184,231 232,235,254
Piatto da torta	80,92,138
Piatto ovale	161,162
Piatto per legumi	162
Piatto per ostriche	85,118,119,120,143
Piatto pesce	121,161
Piatto quadrato	80,180
Piatto rotondo	161,162
Piatto termico	165
Pietra ollare	178
Pinza aragosta	73
Pinza per antipasti e dolci	167
Pinza per dolci	167
Pinza per servire	167
Pinza per torta	167
Pinza per verdure	167
Pirofile e porcellane	143,148,181
Porta badge	173
Porta bastoncini di zucchero	208
Porta bicchieri	143,149
Porta bottiglie	169,171
Porta burro e marmellata	87,99,169
Porta bustine da zucchero	82,96,139,208,209
Porta cannuce	214
Porta chiavi	142
Porta condimenti	129,143,152,169,172
Porta cucchiaini	213
Porta gioie	184
Porta grissini	103,171
Porta macarons	81,157
Porta marmellata	87,159
Porta menù	85,97
Porta numero	85,97,144,170,173
Porta pane porta grissini	103,171
Porta pasticcini	78,79,89,129,139,156,184
Porta patatine fritte	170,178
Porta salatini	81,248,249
Porta salse	172
Porta salviettine	209
Porta sapone	209
Porta sigari	106
Porta spazzolini	213
Porta spezie	142,148
Porta stuzzicadenti	81,158,173
Porta toast	170
Porta tovaglioli	96,140,148,171,208
Porta uovo	169
Porta vivande	196,198
Portaghiaccio termico	94,135,217,218,219,220
Posacenere	103,106,168
Posate	7 <> 43,250,256 <> 259
Presentoire	83,89
Quarta posata	62 <> 65,115
Rechaud	196,198
Rinfresca macedonia	85
Rinfrescatore per yogurt	85,199
Rinfrescavino bianco	218,219
Risottiera	143,148
<b>S</b>	
Salsiera	166

	Pag
Scaldacaffè	197
Scaldavivande	196,198
Schiaccianoci	174
Scodella lavadita	168
Secchiello per ghiaccio	84,94,104,105,135,213,21 4215,216,217,218,219,220 221,222,223,228,233,254
Secchiello per ghiaccio termico	94,135,217,218,219,220
Secchiello per spumante	84,94,104,105,135,213,21 4215,216,217,218,219,220 221,222,223,225,228,233 254
Segnaposto	144,170
Servizio per antipasto	81
Servizio per caffè	86,203
Servizio per caviale	98
Servizio per champagne	219
Servizio per latte macchiato	209
Servizio per olio e aceto	87,99,158,159
Servizio per pinzimonio	181
Servizio per zucchero	87,156,203
Set impilabile	248,249
Set per ceviche	173
Set sale e pepe	87,99,106,158,159,166
Shaker	213
Sottobicchiere	131,133,140,147,154,157
Sottobottiglia	131,133,140,147,154,157 235
Sottopiatto	101,103,124,128,131,133 140,147,153,154,156,171 184,231,232,235,254
Spargipepe	99,106,158,166
Spargisale	81,87,99,106,158,159,166 232
Spumantiera	215,225,228
Stiletto aragosta	73
Street cover	131,133
Supporto	180,181
Supporto numero da tavola	85,97,144,170,173
Supporto secchiello spumante/vino	84,94,95,105,123,135,216 217,218,219,220,221,223
<b>T V W Z</b>	
Taglia tartufi	175
Targhette	85,97,144,170,173
Tazza	249
Tegame	241,243
Tegamino friggiuova	168
Teiera	82,145,201,202,205,206 207
Teiera termica	205
Tovaglietta americana	124,128,131,133,184
Vasetto portafiori	140,170
Vassoio	77,80,90,91,92,96,97,101 102,103,113,115,119,124 125,128,129,136,137,143 147,149,151,152,153,154 162,163,171,172,184,192 197,208,231,235,247,250
Vassoio concavo	171
Vassoio conto	103,137
Vassoio gn	77,90
Vassoio ovale	80,92,101,102,113,119,153 231,235
Vassoio quadrato	91,102,113,115,124,125 128,129,136,147,152,184
Vassoio rettangolare	77,90,91,92,96,97,102,113 124,125,128,129,136,137 147,151,152,153,154,162 163,171,172,184,192,197 208,250
Vassoio rotondo	77,91,92,103,143,147,149 151,154,192,247
Versatore per profumo	87
Versavino	169,199
Vetrina refrigerata	274 <> 279
Wok	243
Zuccheriera	82,106,145,201,202,205 206,207,208,209
Zuppiera	86,166,196,198



# Index

## A B

	Page
Accessories	73
Afternoon tea stand	83
Amenities tray	77,90,91,101,102,124,128 137,152,154,161,163,184 231,235
Asparagus tongs	167
Bar spoon	73,214
Beverage server	195,250
Beverage server, insulated	201,202
Big wine party tub	215,225,228
Boston shaker	213
Bottle cooler	218
Bottle opener	174
Bottle stand/coaster	131,133,140,147,154,157 235
Bowl	96,97,101,102,103,104 105,107,118,119,123,138 152,153,155,157,172,188 231,235,247
Bowl, small	78,97,123,138,169
Bread basket	80,96,138,149,151 152,155,235
Bread plate	101,157,232
Bread stand	96
Bread/Pastry tongs	167
Buffet rack	248,249
Buffet showcase, cooled	274 <> 279
Butter cup	81,98

## C

Café au lait set	86,203
Cake server	7 <> 43 69,197,257
Cake stand	80,92,138
Candlestick	83,89,144,199
Carving fork	7 <> 43,69,197,257
Cash tray	137,213
Caviar cup	81,98
Caviar set	98
Caviar spoon	174
Casserole	241,243
Centerpiece	107,118,119,121,138,188 236
Ceviche set	173
Chafing dish	196,198
Champagne bucket	215,225,228
Champagne holder	199
Charger	101,103,124,128,131,133 140,147,153,154,156,171 184,231,232,235,254
Chillcup	81,98
Chilli mill	175
Chopsticks	67
Chopsticks rest	67
Cigar ash tray	103,168
Cloche	83,86,163,168,173
Cloche for wedding cake stand	86,173
Cocktail measuring cup double	213
Cocktail strainer	174
Coffee cup	249
Coffee Design Kit	211
Coffee dispenser solid alcohol heating	197
Coffee pot	82,145,201,202,205,206 207
Coffee pot, insulated	201,202,205
Coffee urn	197
Cookware	241,243
Cooled juice pitcher	201,202
Cork screwer	174
Cover	86,108,161,162,166
Cover for oval meat dish	162
Cover for soup tureen and vegetable dish	86,166
Creamer	106,180,209
Cruet	81,108,158,159,178,232
Cruet set	87,99,108,125,129,142 149,151,152,153,155,158 159,232,236
Cup with feet	80,85,89,213

## DEF

Dish cover	161,162,163
Dome cover for dish	83,86,163,168,173

## Page

Egg cup	169
Electric heating unit	196
Escargot fork	73
Escargot plate	168
Escargot tongs	73,167,168
Eutectic pads	274 < > 279
Finger bowl	168
Finger food	110 <> 115
Finger food insert	115,184
Fish dish	121,161
Fish serving fork	7 <> 43,69,257
Fish serving knife	7 <> 43,69,257
Flatware	7 <> 43,250,256 <> 259
Flower vase	140,170
Food pan	196,198
Fork, roast	71,179
Fruit basket	107,139,152,153,155,157
Fruit bowl	96,97,104,155,188,223 231,235
Fruit salad bowl	78,97,108,248,250
Fruit stand	78,79,82,93,139,156
Fruit tongs	167
Frying pan	241,243
Frying pan for eggs	168

## G H I

Giant champagne bucket	215,225,228
Glass	106,192,247,251,254
Glass coaster	131,133,140,147,154,157
Golf club mixer spoon	73,214
Grated cheese pot	81,99,108,125,129,142 149,151,152,153,155,159 168,232,236
Grater	174
Gravy boat	166
Gueridon	222
Herbs mill	175
Holder	78,79,82,83,85,93,96,118 119,120,138,139,143,156
Hors d'oeuvre tray	142,143,148,151,153,155 180,231,236
Hors d'oeuvre and pastry pliers	167
Ice bucket	84,94,104,105,135,213,214 215,216,217,218,219,220 221,222,223,228,233,254
Ice bucket, insulated	94,135,217,218,219,220
Ice cream cup	98,172,251
Ice tea spoon	7 <> 43
Ice tongs	167,214
Intermezzo cup	170
Infuser jug	195
Induction cooker	196

## J K L

Jam and honey holder	87,159
Jug	195,203,250
Juice dispenser	197
Knife rest	73,197
Knives	7 <> 43,71,72,73,120,179
Ladle	7 <> 43,69,213,257
LED Ice cubes	229
Lobster cracker	73
Lobster pick	73

## M N

Meat dish	161
Milk dispenser	197
Milk pot	82,145,201,202,205,206 207
Mini butter dish	87,99
Mini casserole	241
Mini fork	73,192
Mini spoon	73,192
Mini steamer	115
Mini table stand	173
Mini tray	113,188
Mixing glass	213
Monoportion fork	73,192
Monoportion spoon	69,73,192
Mug	249
Multipurpose bowl	80,138

# Index

	Page
Napkin holder	96,140,148,171,208
Napkin ring	141,149,235
Nut-cracker	174
<b>O P</b>	
Oil and vinegar set	87,99,108,125,129,142 149,151,152,153,155,158 159,232,236
Oil pourer	81,108,158,159,178,232
Oval meat dish	161
Oval dish/china	181
Oyster fork	7 <> 43
Oyster knife	120
Oyster plate	85,118,119,120,143
Parmesan spoon	7 <> 43
Party forks	73,192
Party spoons	7 <> 43
Pastry pliers	167
Pastry stand	79,82,139,156
Paté holder	87,99,169
Pepper grinder	175
Pepper shaker	99,106,158,166
Perfume drops dispenser	87
Petit four stand	78,80,82,92,136,139,156
Petit marmite	196,198
Pie pliers	167
Pinzimonio set	181
Plate cover, round	161,162,163
Plates	85,97,144,170,173
Pliers	73,167,168,203,214
Polycarbonate drinkware	247 <> 251
Porcelain insert	143,148,181
Presentoire	83,89
Punch bowl	89,213
<b>R S</b>	
Relish dish	81,248,249
Room service system	165
Salad bowl	78,97,108,248,250
Salt and pepper set	81,87,99,106,158,159,166 232
Salt cellar	81,87,99,106,158,159,166 232
Salt grinder	175
Salt shaker	81,87,99,106,158,159,166 232
Salt spoon	73,192
Salt/Pepper dispenser	81,87,99,106,158,159,166 232
Sauce boat	166
Sauce bowl	172
Sauce spoon	7 <> 43,257
Saucepan	241,243
Saucer	131,133,140,147,154,157
Seafood stand	85,93,118,119,120,143
Serving fork	7 <> 43,69,197,257
Serving pliers	167
Serving spoon	7 <> 43,69,73,197,257
Set for Risotti	143,148
Shaker	213
Show plate	101,103,124,128,131,133 140,147,153,154,156,171 184,231,232,235,254
Small spoon	73,192
Snack server	81,248,249
Soapstone	178
Soap tray	209
Soup cup	98,166
Soup tureen	86,166,196,198
Spaghetti tongs	167
Square tray	91,102,113,115,124,125 128,129,136,147,152,184
Stackable tray	90,91
Stock pot	241,243
Street cover	131,133
Sugar bowl	82,106,145,201,202,205 206,207,208,209
Sugar, milk and coffee set	86,203
Sugar set	87,156,203
Sugar tongs	167,203
Sugar/Tea bags holder	82,96,139,208,209

	Page
Supreme cup	81,98
<b>T</b>	
Table grill	115,178
Table mat	124,128,131,133,184
Table number	85,97,144,170,173
Table number stand	85,97,144,170,173
Tall container	213
Tea cup	249
Tea pot	82,145,201,202,205,206 207
Tea pot, insulated	205
Thermal serving unit	181
Toast rack	170
Toast/Pastry tongs	167
Tongs	73,167,168,203,214
Toothpick holder	81,158,173
Tray	77,80,90,91,92,96,97,101 102,103,113,115,119,124 125,128,129,136,137,143 147,149,151,152,153,154 162,163,171,172,184,192 197,208,231,235,247,250
Tray gn	77,90
Tray, oval	80,92,101,102,113,119,153 231,235
Tray, rectangular	77,90,91,92,96,97,102,113 124,125,128,129,136,137 147,151,152,153,154,162 163,171,172,184,192,197 208,250
Tray, round	77,91,92,103,143,147,149 151,154,192,247
Tray, square	91,102,113,115,124,125 128,129,136,147,152,184
Trolley	261 <> 272,280 <> 288
Truffle slicer	175
<b>U V W Y</b>	
Underliner	98
Vacuum jug	201,202
Vase	254
Vegetable dish	86,162,166
Vegetable dish escoffier	162
Vegetable/Meat tongs	167
Vegetable pliers	167
Vichyssoise cup	98,166
Vinegar dispenser	81,108,158,159,178,232
Water pitcher	195,206,250
Water pitcher, insulated	201,202
Wine cooler	84,94,104,105,135,213,21 4215,216,217,218,219,220 221,222,223,225,228,233 254
Wine cooler stand	84,94,95,105,123,135,216 217,218,219,220,221,223
Wine holder	169
Wok	243
Yogurt cooler	199



# Index

## A B

	Page
Accessoires	73
Ardoise	178
Batteries de cuisine	241,243
Beurrir	81,87,98,99,169
Bol	96,97,101,102,103,104
	105,107,118,119,123,138
	152,153,155,157,172,188
	231,235,247
Bol à caviar	81,98
Bol à champagne	215,225,228
Bol à punch	89,213
Bol à rafraichir	118,119,199
Bol à salade de fruits	78,97,108,248,250
Bol à sauce	166
Bol à snacks	81,248,249
Bol avec socle	80,85,89,213
Bol en bois	123
Bol en polycarbonate	246<>250
Bol en polypropylène	254
Bol en verre	80,108
Bol universel	80,138
Boston shaker	213
Bouilleur	197
Borne étouffoir	106
Brasier avec pierres naturelles	115,178
Brasière	241,243
But de canapé	222

## C

Cache eau mineral	171
Cafetière	82,145,201,202,205,206
	207
Cafetière thermique	201,202,205
Carafe	195,206,252
Carafe à eau	195,201,202,206,250
Carafe à eau thermique	201,202
Cartouches eutectiques	274 < > 279
Casse-noix	174
Cendrier	103,106,168
Cendrier à cigares	103,106,168
Centre de table/Compotier	107,118,119,121,138,188
	236
Chafing-dish	196,198
Chandelier	83,89,144,199
Chandelier/bougeoir	89,144
Chariot	261 <> 272,280 <> 288
Chariot de service	91
Chopsticks	67
Cloche pour plat	83,86,163,168,173
Cloche pour plat ovale	163
Cloche pour plat rond	83,86,163,168,173
Cloche support à tartes	86,173
Coffe Design Kit	211
Coffee Urn	197
Conteneur à thé	96,139,208,209
Coquetier	169
Corbeille	96,97,101,102,103,104
	105,118,119,123,138,152
	153,155,157,172,188,231
	235,247
Corbeille à pain	80,96,138,149,151,152
	155,235
Corbeille pour aromatiques condiments	129,143,152,169,172
Corps de chauffe électrique	196
Coupe à beurre	81,98
Coupe à caviar	81,98
Coupe à creme/potage	166
Coupe à crevettes	81,98
Coupe à fruits	98,172,251
Coupe à glace	98,172,251
Coupe à intermezzo	170
Coupe à Martini	170,251
Coupe à punch	89,213
Coupe à suprême	81,98
Coupe à vichyssoise	98,166
Coupe multifonctions	80,138
Coupe sur pied	80,85,89,213
Coupe thermique à glace	172
Coupelle	78,80,81,98,108,138,169
	172,223,248,249,250,254
Coupe-truffes	175

## Page

Couteau à huîtres	120
Couteau à servir poisson	7 <> 43,69
Couteaux	7 <> 43,71,72,73,120,179
Couvercle	86,108,161,162,166
Couvercle légumier	86,166
Couverts	7 <> 43,250,256 <> 259
Couvre-plat	161,162,163
Crémier	106,180,209
Cuiller à bar	73,214
Cuiller à risotto	69,73,197
Cuiller à servir	7 <> 43,69,73,197,257
Cuiller à soda	7 <> 43
Cuillère cocktail	73,214
Cuillère à glace	7 <> 43
Cuillère à parmesan	7 <> 43
Cuillère à sauce	7 <> 43,257
Cuillère à sel	73,192
Cuillère monoportion	69,73,192
Curette à homard	73

## D E F

Décapsuleur	174
Distributeur à jus	197
Distributeur à lait	197
Distributeur de serviettes	96,140,148,171,208
Doseur	213
Douser sel/poivre	81,87,99,106,158,159,166
	232
Ecuelle	168
Etagère	188,248,249
Étiquettes	85,97,144,170,173
Faitout	241,243
Finger food	110 <> 115
Fourchette amuse-bouche	73,192
Fourchette à béquille	71,179
Fourchette à escargots	73
Fourchette à fromage	73
Fourchette à huîtres	7 <> 43
Fourchette à rôtis	71,179
Fourchette à servir	7 <> 43,69,197,257
Fourchette à servir poisson	7 <> 43,69,257
Fourchette cocktail	73,192
Fourchette langouste	73
Fourchette monoportion	73,192
Fromagère	81,99,108,125,129,142
	149,151,152,153,155,159
	168,232,236

## G H I L

Glacette thermique	218
Glaçon lumineux	229
Golf crosse pour cocktail	73,214
Huilier	81,108,158,159,178,232
Huilier/vinaigrier	87,99,108,125,129,142
	149,151,152,153,155,158
	159,232,236
Légumier	86,166
Légumier escoffier	162
Louche	7 <> 43,69,213

## M N O

Marmite traiteur	241,243
Ménagère	87,99,108,125,129,142
	149,151,152,153,155,158
	159,232,236
Mesure à alcool, double	213
Mini faitoute	241
Mini marquer de table	173
Mini spoon	73,192
Mini plateau	113,188
Mini vaporisateur	115
Moulin à herbes	175
Moulin à piment	175
Moulin à poivre	175
Moulin à sel	175
Mug	249
Numéro de table	85,97,144,170,173
Ouvre boîte	174
Ouvre-bouteilles	174

# Index

## P Q

	Page
Panier à fruits	107, 139, 152, 153, 155, 157
Passoire à cocktail	174
Pelle à gâteau / à tarte	7 <> 43 69, 197, 257
Petit sous-plat	131, 133, 140, 147, 154, 157 235
Petite marmite	196, 198
Pied pour seau à champagne	84, 94, 95, 105, 123, 135, 216 217, 218, 219, 220, 221, 223
Pince	73, 167, 168, 203, 214
Pince à asperges	167
Pince à fruits	167
Pince à glace	167, 214
Pince à homard	73
Pince à hors-d'oeuvres et pâtisserie	167
Pince à légumes	167
Pince à pain et pâtisserie	167
Pince à pâtisserie	167
Pince à rôti	167
Pince à servir	167
Pince à spaghetti	167
Pince à sucre	167, 203
Pince à tarte	167
Pince à toast et tarte	167
Plaque à induction	196
Plat à escargots	168
Plat à huîtres	85, 118, 119, 120, 143
Plat à pain	101, 157, 232
Plat à poisson	121, 161
Plat à présentation	101, 103, 124, 128, 140, 147 153, 154, 156, 171, 184, 231 232, 235, 254
Plat oval	161, 162
Plat rond	161, 162
Plateau	77, 80, 90, 91, 92, 96, 97, 101 102, 103, 113, 115, 119, 124 125, 128, 129, 136, 137, 143 147, 149, 151, 152, 153, 154 162, 163, 171, 172, 184, 192 197, 208, 231, 235, 247, 250
Plateau à hors d'oeuvre	142, 143, 148, 151, 153, 155 180, 231, 236
Plateau à monnaie	137, 213
Plateau carré	91, 102, 113, 115, 124, 125 128, 129, 136, 147, 152, 184
Plateau gn	77, 90
Plateau ovale	80, 92, 101, 102, 113, 119, 153 231, 235
Plateau rond	77, 91, 92, 103, 143, 147, 149 151, 154, 192, 247
Plateau, rectangulaire	77, 90, 91, 92, 96, 97, 102, 113 124, 125, 128, 129, 136, 137 147, 151, 152, 153, 154, 162 163, 171, 172, 184, 192, 197 208, 250
Poêle	241, 243
Poivrier	99, 106, 158, 166
Porcelaine	143, 148, 181
Porte brosse à dents	213
Porte confitures	87, 159
Porte cure-dents	81, 158, 173
Porte gobelets	143, 149
Porte gressin	103, 171
Porte macarons	81, 157
Porte petits fours	78, 79, 82, 93, 139, 156, 184
Porte pommes frites	170, 178
Porte savon	209
Porte serviette	209
Porte-appetizers	81, 248, 249
Porte-badge	173
Porte-bouteille	169, 171
Porte-pate/beurre/caviar	87, 99, 169
Porte toast	170
Pot à cuillères	213
Pot à lait	82, 145, 201, 202, 205, 206 207
Pot à sucre	82, 96, 139, 208, 209
Presentoire	83, 89
Quarta Posata	62 <> 65, 115

## R S

Rafraichisseur à bouteille	218
----------------------------	-----

## Page

Rafraichissoir à yogourt	199
Ravier à parmesan	81, 99, 108, 125, 129, 142 149, 151, 152, 153, 155, 159 168, 232, 236
Rechaud à cafe	197
Reibe	174
Rince doigts	168
<b>S</b>	
Saladier	78, 97, 108, 248, 250
Salière	81, 87, 99, 106, 158, 159, 166 232
Saucière	166
Seau à champagne	84, 94, 104, 105, 135, 213, 21 4215, 216, 217, 218, 219, 220 221, 222, 223, 225, 228, 233 254
Seau à glace	84, 94, 104, 105, 135, 213, 21 4215, 216, 217, 218, 219, 220 221, 222, 223, 228, 233, 254
Seau à glace, thermique	94, 135, 217, 218, 219, 220
Seau à vin	84, 94, 104, 105, 135, 213, 21 4215, 216, 217, 218, 219, 220 221, 222, 223, 225, 228, 233 254
Service à caviar	98
Set de table	124, 128, 131, 133, 184
Set pinzimonio	181
Set pour ceviche	173
Set salière, poivrier	81, 87, 99, 106, 158, 159, 166 232
Shaker	213
Soliflore	140, 170
Soupière avec couvercle	86, 166, 196, 198
Sous plat	101, 103, 124, 128, 131, 133 140, 147, 153, 154, 156, 171 184, 231, 232, 235, 254
Sous verre	131, 133, 140, 147, 154, 157
Sous-bouteille	131, 133, 140, 147, 154, 157 235
Street Cover	131, 133
Sucrier	82, 106, 145, 201, 202, 205 206, 207, 208, 209
Support	180, 181
Support à tarte	80, 92, 138
Support avec numéro de table	85, 97, 144, 170, 173
Support pour seau à champagne / à vin	84, 94, 95, 105, 123, 135, 216 217, 218, 219, 220, 221, 223
Support pour toast	170
<b>T V W</b>	
Tasse	249
Théière	82, 145, 201, 202, 205, 206 207
Théière thermique	205
Tire-bouchon	174
Vase à fleurs	140, 170
Verre	106, 192, 247, 251, 254
Verseur de parfum en gouttes	87
Vinaigre	81, 108, 158, 159, 178, 232
Vitrine réfrigérée	274 <> 279
Wok	243



# Alphabetisches Register

<b>A B C</b>	<b>Seite</b>
Ascher	103,106,168
Ascherständer	106
Auflaufform auf Porzellan	181
Austernöffner	120
Badge-Halter	173
Bargestell	248,249
Beilagenschale	168
Bierbecher	251
Blumenvase	140,170
Bonbonsschale	155
Boston Shaker	213
Bowlenlöffel	213
Bratenplatte	161
Bratentopf	241,243
Bratpfanne	241,243
Brot Platte	101,157,232
Brotkorb	80,96,139,149,151,152 155,235
Brottschale	101,103,149,157,232
Buffet Display	188,192
Buffet-Tablett	92,192,247
Butterdose	169
Butterkühler	154,157
Café au Lait-Set	86,203
Cappuccinolöffel	209
Cevichese	173
Chafing dish	196,198
Chafing dish besteck	197
Champagner Bowl	85,95,104,215,225,228
Champagnerflaschenhalter	199
Champagnerglas	192,251
Chilimühle	175
Chillcup	81,98
Cocktailsieb	174
Coffee Urn	197

<b>D E F</b>	
Deckel	86,108,161,162,166
Dessertgestell	83
Dressingbehälter	106,166,180,201,202 203,209
Dressinglöffel	7 <> 43,257
Eierbecher-Set	169
Eierlöffel	7 <> 43
Eierpfanne	168
Einsatz Tablett	115,125,128,184
Eisbecher	251
Eisfruchtbecher, Isoliert	172
Eisgefäß	84,94,104,105,135,213,214 215,216,217,218,219,220 221,222,223,228,233,254
Eisgefäß, Isoliert	94,135,217,218,219,220
Eislöffel	7 <> 43
Eisschale	98,172,251
Eisschaufel	7 <> 43
Eiswasserkrug	195,206,250
Eiswürfel LED	229
Eiszange	167,214
Essig-/Ölflasche	81,108,158,159,178,232
Essig-/Ölflaschenhalter	123,129,143,169,172
Essig-/Ölgestell	87,99,108,142,149,151, 152,153,155,158,159,232 236
Essig-/Öl-Menage	125,129
Ess-Stäbchen Paar	67
Ess-Stäbchen Ablage	67
Etagère	78,79,93,107,139,156
Feuerschale	115,178
Fingerfood-/Vorspeisen-/Butter-Gefäß	138
Fingerschale	168
Fischplatte	161
Flaschenhalter	171
Flaschenteller	131,133,140,147,154,157 235
Fleischgabel	71,179
Früchtekorb	104,105,123,151,223,248
Frühstück Tablett	125,128

<b>G H K</b>	
Gebäckplatte	163
Gebäck- und Servierzange	167

	<b>Seite</b>
Gemüsetopf	241,243
Getränkekühler	218,219
Gewürzmenage	159
Gewürzständer	142,148
Glas	106,192,247,251,254
Glassflasche	108
Glaskrug	195
Glasschale	80,108
Glasuntersatz	131,133,140,147,154,157
Golf Schlegler	73,214
Gratinplatte	162,163
Griffschale	101,231,235
Grifftablett	101,231,235
Grill Pfanne	243
Grissini-Halter	103,107,171
Gueridon	222
Happy Spoon	69
Heizelement	196
Hummergabel	73
Hummerzange	73
Kaffeekanne	82,145,201,202,205,206 207
Kaffeekanne, isoliert	201
Kaffeespender	197
Kaffeetablett	208
Kartenhalter	85,97,170
Kartoffenbehälter	170,178
Kartoffellöffel	7 <> 43
Kasserolle	243
Kaviarkühler	81,98
Kaviarlöffel	174
Kaviarschale	81,98
Korkenheber	174
Korkenzieher	174
Kuchen-/Tortenplatte	80,92,136,138
Käsedose	81,99,108,125,129,142 149,151,152,153,155,159 168,232,236
Käsemesser	73
Kühlschale	118,119
Kühlvitrine	274 <> 279

<b>L M N</b>	
Latte Macchiato-Set	209
Légumier	86,166,196,198
Leuchter	83,89,144,199
Löffelbecher	213
Macaronsträger	81,157
Marmeladegestell	87,159
Martini Glass	170,251
Milchdispenser	197
Milchkaffee-Set	211
Milchkanne	82,145,201,202,205,206 207
Milchkännchen	106,180,203,209
Milch-Kaffee-Zucker-Set	86,203
Mini Bratentopf	241
Mini Butterdose	87,99
Mini Gabel	192
Mini Spoon	192
Mini Tablett	113,186
Mini Verdampfer	115
Mokkaétagère	79,89,139,156
Mug	249
Nussknacker	174
Nussschale	157

<b>O P Q</b>	
Obstschale	78,80,82,92,97,101,102 103,107,118,119,121,138 151,152,153,155,157,172 188,231,247,250,254
Papierbecherständer	143,149
Pâtisserie Tablett	208,235
Petits Fours-Ständer	78,80,82,92,136,139,156
Pfeffermühle	175
Pfefferstreuer	99,106,158,166
Platten	80,161,162,180,188
Platzteller	101,103,124,128,131,133 140,147,153,154,156,171 184,231,232,235,254

# Alphabetisches Register

	<b>Seite</b>
Portionsschöpfer	7 <> 43
Porzellanschale	143,148,181
Presentoire	83,89
Punchbowl	89,213
Quarta Posata	62 <> 65,115

## R S

Reibe	174
Reislöffel	69,73,197,257
Relish-Pickles-Gestell	81,248,249
Rotweinwiege	169
Saftdispenser	197
Saftkrug	195,250
Sahne-/Zucker-Set	86,87,203
Sahnegießer	106,180,209
Sahnekännchen	203
Salat-/Vorlegebesteck	7 <> 43,197,250
Salatzange	167
Salz- und Pfeffergestell	87,99,158,159,166
Salzmühle	175
Sauce Set	172
Saucenlöffel	7 <> 43,257
Sauciere	166
Schale	96,97,101,102,103,104 105,118,119,123,138,152 153,155,157,172,188,231 235,247
Schalenhalter	180
Schlüsselanhänger	142
Schmuckablage/Bonbonträger	129,184
Schnapsbecher	251
Schneckengabel	73
Schneckenzange	73,167,168
Schneckenplatte	168
Serviergestell	83
Serviertablett	101,103,124,128,140,147 153,154,156,171,184,231 232,235,254
Servierwagen	261 <> 272,280 <> 288
Serviettenhalter	96,140,148,171,208
Serviettenring	141,149,235
Set mit Porzellanschale	142,143,148
Shot Glass	106
Snackschale	169
Sorbetschale	170
Speckstein	178
Speisekartenhalter	85,97
Stand für Plastik Platte	149
Steakbesteck	71,179
Steakmessern	71,179
Stielkasserolle	241
Suppenmarmite	196,198
Suppenschöpfer	7 <> 43,69
Suppenstation	196,198
Suppentasse	166
Suppenterrine	86,166,196,198
Street Cover	131,133
Strohalm Halter	214

## T

Tablett	77,80,90,91,92,96,97,101 102,103,113,115,119,124 125,128,129,136,137,143 147,149,151,152,153,154 162,163,171,172,184,192 197,208,231,235,247,25
Tablett Gastronorm	77,90
Tablett für Stoffservietten	209
Tablett, konkave	171
Tablett, oval	80,92,101,102,113,119,1532 31,235
Tablett, quadratisch	91,102,113,115,124,125 128,129,136,147,152,184
Tablett, rechteckig	77,90,91,92,96,97,102,113 124,125,128,129,136,137 147,151,152,153,154,162 163,171,172,184,192,197 208,250
Tablett, rund	77,91,92,103,143,147,149 151,154,192,247
Tafelaufsatz	107,118,119,121,138,188

## Seite

Teeglas	236
Teekanne	188
	82,145,201,202,205,206
	207
Teekanne, Isoliert	205
Teller	161
Tellercloche	83,86,163,168,173
Thermische Ringröhre	181
Tischnummer	144,170,173
Tischnummernständer	85,97,144,170
Tischnummern-Aufsteller	97,170
Tischrestebehälter	214
Tischset	124,128,131,133,184
Toastständer	170
Tortenheber	7 <> 43 69,197
Tranchiergabel	71,179
Tranchiermesser	71,72,179
Tropf-Parfüm Aussteller	87
Trüffel Hobel	175

## U V W Y

Universalschale	80,123,138
Vorlege-/ Aufschnittgabel	73,192
Vorspeisenplatte	142,143,148,151,153,155 180,231,236
Yogurtkühler	85,199
Warmhalteteller	165
Wasserascher	85,97,103
Weinbecher	251
Wein-/Sektkühler	84,94,104,105,135,213,21 4 215,216,217,218,219,220 221,222,223,225,228,233
	254
Weinkühler	218,219
Weinkühlerständer	84,94,95,105,123,135,216 217,218,219,220,221,223
Whisky Becher	251
Wokpfanne	243

## Z

Zahlteller	213
Zahnstocherbehälter	81,158,173
Zuckerdose	82,106,145,201,202,205 206,207,208,209
Zuckergestell	87,156,203
Zuckerständer	156
Zuckerstangengefäß	82,96,139,208,209
Zuckerzange	167,203



# Indice

## A B

	Pág.
Abrebotellas	174
Accesorios	73
Aceitera	81,108,158,159,178,232
Apoyo para chopsticks	67
Apoyo para cubiertos	73,197
Azucarera	82,96,139,208,209
Azucarero	82,106,145,201,202,205 206,207,208,209
Bac rond	143,148
Bajo plato	101,103,124,128,131,133 140,147,153,154,156,171 184,231,232,235,254
Bandeja	77,80,90,91,92,96,97,101 102,103,113,115,119,124 125,128,129,136,137,143 147,149,151,152,153,154 162,163,171,172,184,192 197,208,231,235,247,250
Bandeja concavo	171
Bandeja cuadrada	91,102,113,115,124,125 128,129,136,147,152,184
Bandeja cuentas y propinas	137,213
Bandeja gn	77,90
Bandeja portaseruilletas	209
Bandeja rectangular	77,90,91,92,96,97,102,113 124,125,128,129,136,137 147,151,152,153,154,162 163,171,172,184,192,197 208,250
Bandeja redonda	77,91,92,103,143,147,149 151,154,192,247
Bandeja tartas	80,92,138
Baterias de cocina & accesorios	241,243
Bistequera	243
Bobina térmica	181
Bol à salade de fruits	85
Bol para caviar	81,98
Bol para limpiar dedos	168
Botella	108

## C

Cacerola	241,243
Cafetera	82,145,201,202,205,206 207
Cafetera térmica	201,202,205
Calentador de café	197
Calentador à inducción	196
Calentador eléctrico	196
Candelabro	83,89,144,199
Carros	261 <> 272,280 <> 288
Cascanueces	174
Cazo	7 <> 43,69,213
Cenicero	103,106,168
Cenicero a columna	106
Centro mesa	107,118,119,121,138,188 236
Cesta pan	80,96,103,138,149,151 152,155,235
Cesta para fruta	107,139,152,153,155,157
Cesto por aromaticos y condimentos	129,143,152,169,172
Cevichera	173
Chafing-dish	196,198
Chop sticks	67
Coctelera	213
Coctelera con vaso	213
Coffee Design Kit	211
Colador para cóctel	174
Columna porta cubo champany	84,94,95,105,123,135,216 217,218,219,220,221,223
Contenedor para café	197
Contenedor para zumo de fruta	197
Contenedor sobres té	82,96,139,208,209
Copa caviar	81,98
Copa cóctel camarones	81,98
Copa con base	80,85,89,213
Copa de vidrio	80,108
Copa gazpacho/potage	166
Copa helado y macedonia	98,172,251
Copa mantequilla	81,98
Copa para intermezzo	170
Copa salsa	166

## Pág.

Copa soufflé	166
Copa térmica	172
Copa universal	80,138
Copa vichyssoise	98,166
Copita	78,80,81,98,108,138,169
Cortador de trufas	175
Cuberteria	7 <> 43,250,256 <> 259
Cubitera de champaña	215,225,228
Cubitera hielo	84,94,104,105,135,213,214 215,216,217,218,219,220 221,222,223,228,233,254
Cubitera hielo térmica	94,135,217,218,219,220
Cubito hielo LED	229
Cubo de champagne gigante	95,215,225,228
Cubo vino	84,94,104,105,135,213,214 215,216,217,218,219,220 221,222,223,225,228,233 254
Cubreplatos ovales	162,163
Cubreplatos, redondo	161,162,163
Cuchara arroz	69,73,197
Cuchara cocktail	7 <> 43
Cuchara ensalada	7 <> 43,69,197
Cuchara parmesán	7 <> 43
Cuchara servir	7 <> 43,69,73,197
Cucharita cappuccino	209
Cucharita caviar	174
Cucharita mezcladora	73,214
Cucharita para sal	73,192
Cuchillo ostras	120
Cuchillo servir pescado	7 <> 43,69
Cuchillos	7 <> 43,71,72,73,120,179
Cúpula cubre-plateos	83,86,163,168,173
Cuenco	78,97,101,102,103,108,123 138,139,149,169,188,231 235,247,248,249,250,254
Cuenco con pedestal	80,97
Cúpula refrigerada	274 <> 279

## D E F

Dispensador	188
Dosador sal/pimienta	81,87,99,106,158,159,166 232
Ensaladera	78,97,108,248,250
Entremesera	142,143,148,151,153,155 180,231,236
Finger Food	110 <> 115
Florero	140,170
Frutero	78,79,82,93,139,156
Fuente de marisco	85,118,119,120,143
Fuente oval	161,162
Fuente para Lasagne	142,148,181
Fuente pescado	121,161

## G H J I L

Golf club cucharita coctél	73,214
Gueridon	222
Hoguera con piedras naturales	115,178
Huevera	169
Jarra	203
Jarra agua	195,250
Jarra leche	82,145,201,202,205,206 207
Jarra térmica	201,202
Jarrita lechera	106,180,209
Joyero	184
Juego azucar	87,203
Juego café au lait	86,203
Juego leche, café y azucar	86,203
Individual en madera	124,128,184
Individual en goma	131,133
Inserto por finger food	115,184
Lavadodos	168
Legumbreira	86,166
Legumbreira escoffier	162

## M N O

Mantel individual	124,128,131,133,184
Mantequillera	87,99,169
Marmeladero	87,159,169
Medida bar, doble	213

# Indice

	<b>Pág.</b>
Mini bandeja	113,188
Mini cacerola	241
Mini spoon	73,192
Mini tenedor	73,192
Mini vaporizador	115
Molinillo chile	175
Molinillo hierbas	175
Molinillo pimienta	175
Molinillo sal	175
Mug	249
Número de mesa	85,97,144,170,173
<b>P Q</b>	
Pala para tarta	7 <> 43 69,197
Pala pescado	7 <> 43,69
Palillero	81,158,173
Panera	80,96,138,149,151,152 155,235
Pedestal para tarta	80,92,138
Petit marmite	196,198
Pimentero	99,106,158,166
Pinza asados y verduras	167
Pinza azucar	167,203
Pinza caracoles	73,167,168
Pinza entremeses y pasteles	167
Pinza espagueti	167
Pinza espárragos	167
Pinza frutas	167
Pinza hielo	167,214
Pinza pan y pasteles	167
Pinza pasteles	167
Pinza pasteles y tostadas	167
Pinza servir	167
Pinza verduras	167
Pinzimonio	181
Pizarra	178
Plancha refrigerada	274 < > 279
Platillo para mantequilla	87,99
Platito bajo botellas	131,133,140,147,154,157 235
Platito bajo vasos	131,133,140,147,154,157
Plato caracoles	168
Plato de presentación	101,103,124,128,140,147 153,154,156,171,184,231 232,235,254
Plato huevos	168
Plato ostras	85,118,119,120,143
Plato para pan	101,157,232
Plato térmico	166
Ponchera	89,213
Porcelana	143,148,181
Porta bastoncillos de pan	103,107,171
Porta botellas	169,171,199
Porta cepillo de dientes	213
Porta cucharitas	213
Porta dulces	78,79,89,129,139,156,184
Porta jabón	209
Porta informaciones	85,97
Porta macaron	81,157
Porta numero de mesa	85,97,144,170,173
Porta palillas	214
Porta patatas fritas	170,178
Porta pescado	85,93,118,119,120,143
Porta servilletas	96,140,148,171,208
Porta tarjeta	173
Porta tostadas	170
Porta vasos	143,149
Portallaves	142
Portapan	103,107,171
Portaplatos de plastica	149
Posabotella	131,133,140,147,154,157 235
Posavasos	131,133,140,147,154,157
Posavasos por mug	249
Presentoire	83,89
Puerto paté/mantequilla/caviar	81,98
Quarta Posata	62 <> 65,115
Quesera	81,99,108,125,129,142 149,151,152,153,155,159 168,232,236

<b>R S</b>	<b>Pág.</b>
Rallador	174
Refrigerador para yogurt	85,199
Rompenueces	174
Salero y pimentero	81,87,99,106,158,159,166 232
Salsera	166
Servicio para buffet	188
Servicio para café con leche	209
Servicio para caviar	98
Servicio para champagne	219
Servicio para ensaladas	181
Servicio para Lasagne	142,148,181
Servicio para salsa	172
Servicio por aromaticos y condimentos	142,148
Servicio por entremes	81,248,249
Servilletero	141,149,235
Sopera	86,166,196,198
Soporte platos	83
Soporte multi usos	180,181
Street cover	131,133
<b>T V W</b>	
Tapa	86,108,161,162,166
Tapa legumbreira y sopera	86,166
Tarjetas	85,97,144,170,173
Tazas	249
Tenedor caracoles	73
Tenedor cocktail	73,192
Tenedor diápasos	71,179
Tenedor ensalada	7 <> 43,69,197
Tenedor langostas	73
Tenedor ostras	7 <> 43
Tenedor pescado	7 <> 43,69
Tenedor servir	7 <> 43,69,197
Tetera	82,145,201,202,205,206 207
Tetera térmica	205
Vaso	106,192,247,251,254
Versador de perfume en gotas	87
Vinagrera	81,108,158,159,178,232
Vinagreras con saleros	87,99,108,125,129,142 149,151,152,153,155,158 159,232,236
Wok	243

# Index

<b>Pag</b>		<b>Pag</b>		<b>Pag</b>		<b>Pag</b>		<b>Pag</b>		<b>Pag</b>	
44	73	145	275	264	276	361	205	538	250	602	159
011	261	146	90	265	96	362	205	542	250	603	159
012	261	146GN	90	265	276	363	205	543	251	604	159
013	261	151	197	266	162	364A	205	543N	192	605	248
014	261	151	279	267	162	364B	205	544	169	606	249
015	261	152	279	268	163	364T	205	545	213	607	105
016	261	153	279	269	161	366	205	546	213	608	104
017	261	154	279	270	96	367	205	547	213	609	101
025	174	155	279	271	278	370	221	548	213	609B	231
031	262	161	274	272	165	371	221	549	113	611	159
032	262	162	274	272	278	380	214	549	188	612	101
033	262	163	274	273	165	381	214	549	188	612B	231
034	262	164	151	273	278	382	214	550	249	613	101
035	262	164	274	274	278	406	152	551	213	613B	231
036	262	165	151	275	278	407	152	552	249	614	101
037	262	165	274	280	173	408	152	553	247	614B	231
041	268	166	151	281	173	409	152	554	247	615B	232
042	268	168	151	281	277	410	152	555	247	616AC	101
043	268	169	151	282	115	411	145	555N	192	616B	232
044	268	186	151	282	178	411	152	556	250	616BAC	232
045	268	199	154	282	277	412	145	557	102	617	101
046	268	201	154	283	277	413	145	558	102	617B	231
047	268	202	154	284	277	414	145	558G	119	620	178
047	174	203	154	285	277	438	104	558V	119	621	202
048	174	204	157	287	92	438	215	559	103	622	202
049	174	205	96	288	92	439	104	560	103	623	202
051	265	206	96	289	170	439	215	560	188	624	202
052	265	206	208	289	178	446	170	561	102	624P	202
053	265	208	157	292	156	447	175	562	102	627B	232
054	265	208	157	293	156	448	171	562G	118	630B	231
055	265	209	154	294	156	462	175	562V	118	631	206
056	265	210	154	295	92	464	175	563	102	632	206
057	265	211	163	296	92	466	175	563	188	633	206
071	266	220	89	297	92	473	174	564	102	634	206
072	266	221	269	298	92	485	120	565	108	635	206
076	266	222	269	301	98	497	158	566	108	639	203
077	266	223	269	301A	98	498	99	567	103	641	201
081	267	224	269	301B	98	499	209	568	103	642	201
082	267	225	173	301C	98	500B	280	569	103	643	201
086	267	225	269	302	285	500N	280	570	106	644	201
087	267	229	172	304	159	502	155	570	180	644P	201
091	264	230	172	305	147	503	169	571	106	645	201
092	264	231	161	306	149	504	169	572	108	646	202
093	264	232	171	307	149	504	281	572A	108	647	201
094	264	233	161	308	149	505	152	572	178	648	202
094	172	235	121	308	285	505	281	574	180	649	203
095	264	235G	121	309	148	506	99	575	180	651	207
098	172	235	162	309	285	507	99	576	181	652	207
099	254	236	162	310	149	508	158	577	108	653	207
101	270	236	199	312	148	509	158	578	108	654	207
102	270	238	163	313	147	510	158	579	181	657	85
103	156	241	161	314	171	510B	282	580	181	658	229
103	270	242	107	315	147	510N	282	581	180	660	219
104	270	242G	120	316	147	510ST	158	582	180	661	213
105	157	24202G	120	317	149	511	166	582	181	662	218
105	270	243	161	319	147	512	159	583	181	663	218
106	157	245	163	320	147	513	99	584	108	664	218
106	270	247	83	321	149	514	283	585	108	665	213
107	270	247	163	322	287	514P	106	588	247	666	218
121	263	250	91	323	147	514S	106	588P	192	666A	219
122	263	251	161	324	148	515	283	590	249	666B	123
123	263	252	118	325	148	516	96	591	247	666C	105
124	263	252G	118	327	148	516	208	591P	192	666C	223
125	263	253	163	328	287	517	254	592	249	666E	94
126	263	254	97	329	287	518	96	593	249	666E	220
127	263	255	89	331	153	520	113	594	180	666F	84
131	171	256	91	332	153	520B	284	594	209	666F	216
136	208	257	89	332	286	520N	284	595	209	666G	135
137	91	258	89	333	153	522	155	596	104	666G	217
138	91	259	97	334	153	524	285	596	223	666H	221
139	91	260	178	335	153	525	99	597	105	666I	95
140	91	261	276	336	153	525	285	597	222	666W	222
141	90	262	119	337	153	526	113	598	105	666Z	222
141GN	90	262	276	338	286	527	251	598	222	668	94
141	275	262G	119	339	286	528	168	598	225	668	220
142	275	26202G	120	350	158	530	115	599	104	669	94
143	97	26203G	120	350	232	531	251	599	123	669	220
143	275	26204G	120	352	232	533	251	599	223	670	218
144	90	263	162	354	169	534	251	599	223	671	170
144GN	90	263	276	355	169	535	251	600	250	672	219
144	275	264	162	356	172	536	251	601	159	675	171



# Index

<b>Pag</b>		<b>Pag</b>		<b>Pag</b>		<b>Pag</b>		<b>Pag</b>		<b>Pag</b>	
675P	171	792	184	902	208	986	85	7092	199	430502SS	99
676	218	793	125	903	170	987	85	7093	83	430510SS	158
678	219	793	129	904	168	988	87	7093	199	430511SS	166
679	219	794	125	905	171	989	83	7094	83	430603	159
680	219	794	129	905P	171	994	97	7094	199	10001108	174
681	219	795	124	906	67	994C	173	7199	196	10001108	192
682	195	795	128	907	97	995A	85	7199A	196	10001109	69
683	214	795	184	909	105	995B	85	7199B	196	10001110	69
684	214	796	124	909	228	996	170	7199C	196	10001110	197
685	95	796	128	909B	233	998	169	7201	196	10001111	69
685	215	796	184	910	105	999C	106	7201A	196	10001111	197
686	95	799	123	910	228	1001	235	7201B	196	10001115	69
686	215	800	136	910B	233	1002	235	7201C	196	10001116	69
688	104	801	136	911	168	1003	235	7204	197	10001116	197
688	215	802	129	912	105	1004	235	7206	197	10001120	69
689	104	802	136	912	228	1005	235	7208	197	10001121	69
689	215	802	184	912B	233	1006	236	7999	199	10001122	69
691	195	802	184	913	173	1006	256	20705	155	10001122	197
700	178	803C	211	922	87	1007	236	22004	246	10001123	69
700	208	804	123	935	81	1008	236	24202	107	10001123	197
701	166	804	129	936	86	1009	236	26202	107	10001124	69
702	99	805	137	937	80	1010	236	26203	107	10001125	73
703	209	806	137	938	80	1801	241	26204	107	10001126	73
704	96	807	136	939	86	1811	241	31802	148	10001127	69
704	208	808	136	939	203	1811	241	51610	96	10001128	66
706	209	809	136	940	86	1821	241	52922	113	10001128B	66
707	169	810	137	940	203	1821	241	53706	113	10001128N	66
708	213	811	142	941	213	1831	241	53706	188	10001128O	66
709	173	812	142	941	214	1841	241	53706	188	10001128S	66
710	169	813	140	942	87	1851	241	53712	113	10001129	65
711	169	814	140	943	87	2101	243	53712	188	10001129	115
712	98	817	142	944	86	2111	243	53712	188	10001131	192
713	98	819	143	945	86	2121	243	56022G	119	10001136	70
714	98	820	143	946	86	2131	243	56022V	119	10001136	179
715	157	825	142	947	87	2151	243	56422G	118	10001137	73
716	154	826	138	949	85	2162	243	56422V	118	10001138	73
719	106	827	138	950	78	2178	243	58912	248	10001139	73
720	169	828	138	951	82	2179	243	58922	248	10001140	73
721	172	830	139	952	82	2180	243	58928	248	10001141	69
722	98	831	143	953	82	3200	133	58928W	223	10001142	69
723	98	833	140	954	82	3201	133	59870	225	10001142	197
725	98	834	97	956	168	3202	133	61739B	232	10001143	73
726	170	836	143	957	82	3300	133	67301	94	10001144	71
727	170	837	142	958	80	3301	133	67301	220	10001144	72
729	213	838	140	959	80	3302	133	67304	94	10001144	179
730	104	839	140	960	80	3403	131	67304	220	10001144B	72
730	228	840	139	961	80	3404	131	67701	218	10001144N	72
731	166	841	138	962	80	3405	131	67704	218	10001144O	72
732	166	842	139	963	77	3503	131	68702	195	10001144OS	72
736	166	843	135	963GN	77	3504	131	68703	195	10001145	71
741	168	843	155	964	77	3505	131	69202	195	10001145	179
751	168	843	217	965	77	3600	133	69203	195	10001146	179
752	168	844	155	966	77	3601	133	81601	141	10001147	73
771	167	846	140	967	77	3602	133	81602	141	10001150	73
771	203	847	139	968	81	7001B	93	81603	141	10001150	214
772	167	848	139	969	81	7002B	93	81604	141	10001151	213
773	167	848	155	970	81	7003A	156	81605	141	10001175	73
774	167	849	157	971	81	7003B	156	81606	141	10001175	197
775	167	851	143	972	84	7004A	93	84501	135	10101136	71
777	167	852	143	972	216	7004B	93	84501	217	10101136	179
778	167	856	135	972P	84	7011	188	84504	135	10131140	166
779	167	856	217	972P	216	7011	188	84504	217	10141136	71
779	168	858	138	973	84	7011E	192	85301	144	10141136	179
782	166	860	138	973	216	7011E	188	85302	144	10201136	71
787	125	861	137	973P	84	7012	192	85303	144	10201136	179
787	129	862	137	973P	216	7060	89	85401	142	10201143	73
788	124	863	97	974	83	7061	144	85402	142	10201144	209
788	128	863	137	975	81	7062	144	85403	142	10231136	71
789	124	864	97	976	81	7063	144	94003	87	10231136	179
789	128	866	144	976C	81	7064	144	94003	203	10341136	71
791	115	870	103	976S	81	7071	89	94004	87	10341136	179
791	124	871	107	977	78	7072	89	94004	203	10521108	73
791	128	886	254	978	79	7073	89	94005	86	10521131	73
791	184	888	254	980A	79	7086	198	94005	203	10701136	71
791AC	115	891	254	980B	79	7087	198	97803	79	10711136	71
791AC	125	892	254	981A	78	7088	198	98402	83	TU0687G	195
791AC	129	899	105	981B	78	7088A	198	200779	73	TU0692V	195
791AC	184	899	228	982	82	7089	198	290576	181		
791E	113	899B	233	983	85	7089A	198	430491	159		
792	124	901	170	984	83	7090	199	430491SS	159		
792	128	902	178	985	83	7092	83	430502	99		









25065 LUMEZZANE - BRESCIA - ITALIA - VIA MONTNI 176  
TEL. 0308921441 - FAX 0308925075 - [MEPRA@MEPRA.IT](mailto:MEPRA@MEPRA.IT)  
[WWW.MEPRA.COM](http://WWW.MEPRA.COM)